

SAMBA Project Documentation

6th June 2003

This book is a collection of HOWTOs added to Samba documentation over the years. Samba is always under development, and so is its' documentation. This release of the documentation represents a major revision or layout as well as contents. The most recent version of this document can be found at <http://www.samba.org/> on the "Documentation" page. Please send updates to [Jelmer Vernooij](#), [John H. Terpstra](#) or [Gerald \(Jerry\) Carter](#).

The Samba-Team would like to express sincere thanks to the many people who have with or without their knowledge contributed to this update. The size and scope of this project would not have been possible without significant community contribution. A not insignificant number of ideas for inclusion (if not content itself) has been obtained from a number of Unofficial HOWTOs - to each such author a big "Thank-you" is also offered. Please keep publishing your Unofficial HOWTO's - they are a source of inspiration and application knowledge that is most to be desired by many Samba users and administrators.

Legal Notice

This documentation is distributed under the GNU General Public License (GPL) version 2. A copy of the license is included with the Samba source distribution. A copy can be found on-line at <http://www.fsf.org/licenses/gpl.txt>

Attributions

Introduction to Samba

- David Lechnyr <david@lechnyr.com>

How to Install and Test SAMBA

- Andrew Tridgell <tridge@samba.org>
- Jelmer Vernooij <jelmer@samba.org>
- John Terpstra <jht@samba.org>
- Karl Auer

FastStart for the Impatient

- John Terpstra <jht@samba.org>

Server Types and Security Modes

- Andrew Tridgell <tridge@samba.org>
- Jelmer Vernooij <jelmer@samba.org>
- John Terpstra <jht@samba.org>

Domain Control

- John Terpstra <jht@samba.org>
- Gerald Carter <jerry@samba.org>
- David Bannon <dbannon@samba.org>

Backup Domain Control

- John Terpstra <jht@samba.org>
- Volker Lendecke <Volker.Lendecke@SerNet.DE>

Domain Membership

- John Terpstra <jht@samba.org>
- Jeremy Allison <jra@samba.org>
- Gerald Carter <jerry@samba.org>
- Andrew Tridgell <tridge@samba.org>
- Jelmer Vernooij <jelmer@samba.org>

Stand-Alone Servers

- John Terpstra <jht@samba.org>

MS Windows Network Configuration Guide

- John Terpstra <jht@samba.org>

Samba / MS Windows Network Browsing Guide

- John Terpstra <jht@samba.org>

Account Information Databases

- Jelmer Vernooij <jelmer@samba.org>
- Gerald Carter <jerry@samba.org>
- Jeremy Allison <jra@samba.org>
- John Terpstra <jht@samba.org>
- Olivier (lem) Lemaire <olem@IDEALX.org>

Mapping MS Windows and Unix Groups

- Jean François Micouleau
- Gerald Carter <jerry@samba.org>
- John Terpstra <jht@samba.org>

File, Directory and Share Access Controls

- John Terpstra <jht@samba.org>
- Jeremy Allison <jra@samba.org>

File and Record Locking

- Jeremy Allison <jra@samba.org>
- Jelmer Vernooij <jelmer@samba.org>
- John Terpstra <jht@samba.org>
- Eric Roseme <eric.roseme@hp.com>

Securing Samba

-
- Andrew Tridgell <tridge@samba.org>
 - John Terpstra <jht@samba.org>
- Interdomain Trust Relationships**
- John Terpstra <jht@samba.org>
 - Rafal Szczesniak <mimir@samba.org>
- Hosting a Microsoft Distributed File System tree on Samba**
- Shirish Kalele <samba@samba.org>
- Classical Printing Support**
- Kurt Pfeifle <kpfeifle@danka.de>
- CUPS Printing Support in Samba 3.0**
- Kurt Pfeifle <kpfeifle@danka.de>
- Stackable VFS modules**
- Jelmer Vernooij <jelmer@samba.org>
 - John Terpstra <jht@samba.org>
 - Alexander Bokovoy
 - Tim Potter
 - Simo Sorce
- Integrated Logon Support using Winbind**
- Tim Potter <tpot@linuxcare.com.au>
 - Andrew Tridgell <tridge@samba.org>
 - Naag Mummaneni <getnag@rediffmail.com>
 - Jelmer Vernooij <jelmer@samba.org>
 - John Terpstra <jht@samba.org>
- Advanced Network Management**
- John Terpstra <jht@samba.org>
- System and Account Policies**
- John Terpstra <jht@samba.org>
- Desktop Profile Management**
- John Terpstra <jht@samba.org>
- PAM based Distributed Authentication**
- John Terpstra <jht@samba.org>
 - Stephen Langasek <vorlon@netexpress.net>
- Integrating MS Windows networks with Samba**
- John Terpstra <jht@samba.org>
- Unicode/Charsets**
- Jelmer Vernooij <jelmer@samba.org>
 - TAKAHASHI Motonobu <monyo@home.monyo.com>
- Samba Backup Techniques**
- John Terpstra <jht@samba.org>
- High Availability Options**
- John Terpstra <jht@samba.org>
- Upgrading from Samba-2.x to Samba-3.0.0**
- Jelmer Vernooij <jelmer@samba.org>
- Migration from NT4 PDC to Samba-3 PDC**
- John Terpstra <jht@samba.org>
- SWAT - The Samba Web Administration Tool**
- John Terpstra <jht@samba.org>
- The samba checklist**
- Andrew Tridgell <tridge@samba.org>
 - Jelmer Vernooij <jelmer@samba.org>
- Analysing and solving samba problems**
- Gerald Carter <jerry@samba.org>
 - Jelmer Vernooij <jelmer@samba.org>
 - David Bannon <dbannon@samba.org>
- Reporting Bugs**
- Jelmer Vernooij <jelmer@samba.org>
-

-
- Someone; Tridge or Karl Auer perhaps?

How to compile SAMBA

- Jelmer Vernooij <jelmer@samba.org>
- Someone; Jerry perhaps?

Portability

- Jelmer Vernooij <jelmer@samba.org>

Samba and other CIFS clients

- Jim McDonough <jmcd@us.ibm.com>
- Jelmer Vernooij <jelmer@samba.org>

Samba Performance Tuning

- Paul Cochrane <paulc@dh.scot.nhs.uk>
- Jelmer Vernooij <jelmer@samba.org>
- John Terpstra <jht@samba.org>

DNS and DHCP Configuration Guide

- John Terpstra <jht@samba.org>

Further Resources

- Jelmer Vernooij <jelmer@samba.org>
- David Lechnyr <david@lechnyr.com>

Contents

I. General Installation	22
1. Introduction to Samba	23
1.1. Background	23
1.2. Terminology	23
1.3. Related Projects	24
1.4. SMB Methodology	25
1.5. Epilogue	25
1.6. Miscellaneous	26
2. How to Install and Test SAMBA	27
2.1. Obtaining and installing samba	27
2.2. Configuring samba (smb.conf)	27
2.2.1. Example Configuration	27
2.2.1.1. Test your config file with testparm	27
2.2.2. SWAT	28
2.3. Try listing the shares available on your server	28
2.4. Try connecting with the unix client	28
2.5. Try connecting from a DOS, WfWg, Win9x, WinNT, Win2k, OS/2, etc... client	28
2.6. What If Things Don't Work?	28
2.7. Common Errors	29
2.7.1. Why are so many smbd processes eating memory?	29
2.7.2. I'm getting "open_oplock_ipc: Failed to get local UDP socket for address 100007f. Error was Cannot assign requested" in the logs	30
3. FastStart for the Impatient	31
3.1. Note	31
II. Server Configuration Basics	32
4. Server Types and Security Modes	33
4.1. Features and Benefits	33
4.2. Server Types	33
4.3. Samba Security Modes	34
4.3.1. User Level Security	34
4.3.1.1. Example Configuration	35
4.3.2. Share Level Security	35
4.3.2.1. Example Configuration	35
4.3.3. Domain Security Mode (User Level Security)	35
4.3.3.1. Example Configuration	35

4.3.4.	ADS Security Mode (User Level Security)	36
4.3.4.1.	Example Configuration	37
4.3.5.	Server Security (User Level Security)	37
4.3.5.1.	Example Configuration	38
4.4.	Seamless Windows Network Integration	38
4.5.	Common Errors	39
4.5.1.	What makes Samba a SERVER?	39
4.5.2.	What makes Samba a Domain Controller?	40
4.5.3.	What makes Samba a Domain Member?	40
4.5.4.	Constantly Losing Connections to Password Server	40
5.	Domain Control	41
5.1.	Features and Benefits	41
5.2.	Basics of Domain Control	43
5.2.1.	Domain Controller Types	43
5.2.2.	Preparing for Domain Control	44
5.3.	Domain Control - Example Configuration	46
5.4.	Samba ADS Domain Control	48
5.5.	Domain and Network Logon Configuration	48
5.5.1.	Domain Network Logon Service	48
5.5.1.1.	Example Configuration	48
5.5.1.2.	The Special Case of MS Windows XP Home Edition	49
5.5.1.3.	The Special Case of Windows 9x / Me	49
5.5.2.	Security Mode and Master Browsers	50
5.6.	Common Problems and Errors	51
5.6.1.	I cannot include a '\$' in a machine name	51
5.6.2.	I get told "You already have a connection to the Domain..." or "Cannot join domain, the credentials supplied conflict with an existing set.." when creating a machine trust account.	51
5.6.3.	The system can not log you on (C000019B)....	51
5.6.4.	The machine trust account for this computer either does not exist or is not accessible.	52
5.6.5.	When I attempt to login to a Samba Domain from a NT4/W2K workstation, I get a message about my account being disabled.	52
5.6.6.	Until a few minutes after Samba has started, clients get the error "Domain Controller Unavailable"	52
6.	Backup Domain Control	53
6.1.	Features And Benefits	53
6.2.	Essential Background Information	54
6.2.1.	MS Windows NT4 Style Domain Control	54
6.2.1.1.	Example PDC Configuration	55
6.2.2.	Active Directory Domain Control	55
6.2.3.	What qualifies a Domain Controller on the network?	55
6.2.4.	How does a Workstation find its domain controller?	56
6.3.	Backup Domain Controller Configuration	56
6.3.1.	Example Configuration	56
6.4.	Common Errors	57
6.4.1.	Machine Accounts keep expiring, what can I do?	57
6.4.2.	Can Samba be a Backup Domain Controller to an NT4 PDC?	57
6.4.3.	How do I replicate the smbpasswd file?	57
6.4.4.	Can I do this all with LDAP?	57

7. Domain Membership	58
7.1. Features and Benefits	58
7.2. MS Windows Workstation/Server Machine Trust Accounts	58
7.2.1. Manual Creation of Machine Trust Accounts	59
7.2.2. Using NT4 Server Manager to Add Machine Accounts to the Domain	60
7.2.3. "On-the-Fly" Creation of Machine Trust Accounts	61
7.2.4. Making an MS Windows Workstation or Server a Domain Member	61
7.2.4.1. Windows 200x XP Professional	61
7.2.4.2. Windows NT4	61
7.2.4.3. Samba	61
7.3. Domain Member Server	62
7.3.1. Joining an NT4 type Domain with Samba-3	62
7.3.2. Why is this better than security = server?	63
7.4. Samba ADS Domain Membership	64
7.4.1. Setup your smb.conf	64
7.4.2. Setup your /etc/krb5.conf	64
7.4.3. Create the computer account	65
7.4.3.1. Possible errors	65
7.4.4. Test your server setup	65
7.4.5. Testing with smbclient	66
7.4.6. Notes	66
7.5. Common Errors	66
7.5.1. Can Not Add Machine Back to Domain	66
7.5.2. Adding Machine to Domain Fails	66
8. Stand-Alone Servers	68
8.1. Features and Benefits	68
8.2. Background	68
8.3. Example Configuration	69
8.3.1. Reference Documentation Server	69
8.3.2. Central Print Serving	69
8.4. Common Errors	70
9. MS Windows Network Configuration Guide	71
9.1. Note	71
III. Advanced Configuration	72
10.Samba / MS Windows Network Browsing Guide	73
10.1. Features and Benefits	73
10.2. What is Browsing?	74
10.3. Discussion	75
10.3.1. NetBIOS over TCP/IP	75
10.3.2. TCP/IP - without NetBIOS	75
10.3.3. DNS and Active Directory	76
10.4. How Browsing Functions	76
10.4.1. Setting up WORKGROUP Browsing	77
10.4.2. Setting up DOMAIN Browsing	78
10.4.3. Forcing samba to be the master	79
10.4.4. Making samba the domain master	80

10.4.5.	Note about broadcast addresses	80
10.4.6.	Multiple interfaces	80
10.4.7.	Use of the Remote Announce parameter	80
10.4.8.	Use of the Remote Browse Sync parameter	81
10.5.	WINS - The Windows Internetworking Name Server	81
10.5.1.	Setting up a WINS server	82
10.5.2.	WINS Replication	83
10.5.3.	Static WINS Entries	83
10.6.	Helpful Hints	83
10.6.1.	Windows Networking Protocols	83
10.6.2.	Name Resolution Order	84
10.7.	Technical Overview of browsing	84
10.7.1.	Browsing support in samba	85
10.7.2.	Problem resolution	85
10.7.3.	Browsing across subnets	86
10.7.3.1.	How does cross subnet browsing work ?	86
10.8.	Common Errors	89
10.8.1.	How can one flush the Samba NetBIOS name cache without restarting samba?	89
10.8.2.	My client reports "This server is not configured to list shared resources"	89
11.	Account Information Databases	90
11.1.	Features and Benefits	90
11.2.	Technical Information	91
11.2.1.	Important Notes About Security	92
11.2.1.1.	Advantages of Encrypted Passwords	93
11.2.1.2.	Advantages of non-encrypted passwords	93
11.2.2.	Mapping User Identifiers between MS Windows and Unix	93
11.3.	Account Management Tools	93
11.3.1.	The <i>smbpasswd</i> Command	94
11.3.2.	The <i>pdbedit</i> Command	94
11.4.	Password Backends	95
11.4.1.	Plain Text	95
11.4.2.	smbpasswd - Encrypted Password Database	96
11.4.3.	tdbsam	96
11.4.4.	ldapsam	96
11.4.4.1.	Supported LDAP Servers	97
11.4.4.2.	Schema and Relationship to the RFC 2307 posixAc- count	97
11.4.4.3.	OpenLDAP configuration	98
11.4.4.4.	Initialise the LDAP database	99
11.4.4.5.	Configuring Samba	100
11.4.4.6.	Accounts and Groups management	101
11.4.4.7.	Security and sambaAccount	101
11.4.4.8.	LDAP special attributes for sambaAccounts	102
11.4.4.9.	Example LDIF Entries for a sambaAccount	102
11.4.4.10.	Password synchronisation	103
11.4.4.11.	ldap trust ids	103
11.4.5.	MySQL	103
11.4.5.1.	Creating the database	104
11.4.5.2.	Configuring	104

11.4.5.3. Using plaintext passwords or encrypted password . . .	104
11.4.5.4. Getting non-column data from the table	104
11.4.6. XML	105
11.5. Common Errors	105
11.5.1. Users can not logon - Users not in Samba SAM	105
11.5.2. Users are being added to the wrong backend database	105
11.5.3. auth methods does not work	105
12. Mapping MS Windows and Unix Groups	109
12.1. Features and Benefits	109
12.2. Discussion	109
12.2.1. Example Configuration	110
12.3. Configuration Scripts	111
12.3.1. Sample smb.conf add group script	111
12.3.2. Script to configure Group Mapping	111
12.4. Common Errors	112
12.4.1. Adding Groups Fails	112
12.4.2. Adding MS Windows Groups to MS Windows Groups Fails . .	112
13. File, Directory and Share Access Controls	113
13.1. Features and Benefits	113
13.2. File System Access Controls	114
13.2.1. MS Windows NTFS Comparison with Unix File Systems . . .	114
13.2.2. Managing Directories	115
13.2.3. File and Directory Access Control	115
13.3. Share Definition Access Controls	117
13.3.1. User and Group Based Controls	117
13.3.2. File and Directory Permissions Based Controls	117
13.3.3. Miscellaneous Controls	118
13.4. Access Controls on Shares	118
13.4.1. Share Permissions Management	119
13.4.1.1. Windows NT4 Workstation/Server	120
13.4.1.2. Windows 200x/XP	120
13.5. MS Windows Access Control Lists and Unix Interoperability	121
13.5.1. Managing UNIX permissions Using NT Security Dialogs	121
13.5.2. Viewing File Security on a Samba Share	122
13.5.3. Viewing file ownership	122
13.5.4. Viewing File or Directory Permissions	122
13.5.4.1. File Permissions	123
13.5.4.2. Directory Permissions	123
13.5.5. Modifying file or directory permissions	123
13.5.6. Interaction with the standard Samba create mask parameters .	124
13.5.7. Interaction with the standard Samba file attribute mapping . .	125
13.6. Common Errors	125
13.6.1. Users can not write to a public share	125
13.6.2. I have set force user and samba still makes <i>root</i> the owner of all the files I touch!	127
14. File and Record Locking	128
14.1. Features and Benefits	128
14.2. Discussion	128
14.2.1. Opportunistic Locking Overview	129
14.2.1.1. Exclusively Accessed Shares	131

14.2.1.2. Multiple-Accessed Shares or Files	131
14.2.1.3. Unix or NFS Client Accessed Files	131
14.2.1.4. Slow and/or Unreliable Networks	131
14.2.1.5. Multi-User Databases	131
14.2.1.6. PDM Data Shares	132
14.2.1.7. Beware of Force User	132
14.2.1.8. Advanced Samba Opportunistic Locking Parameters .	132
14.2.1.9. Mission Critical High Availability	132
14.3. Samba Opportunistic Locking Control	133
14.3.1. Example Configuration	134
14.3.1.1. Disabling Oplocks	134
14.3.1.2. Disabling Kernel OpLocks	134
14.4. MS Windows Opportunistic Locking and Caching Controls	135
14.4.1. Workstation Service Entries	137
14.4.2. Server Service Entries	137
14.5. Persistent Data Corruption	138
14.6. Common Errors	138
14.6.1. locking.tdb error messages	139
14.7. Additional Reading	139
15. Securing Samba	140
15.1. Introduction	140
15.2. Features and Benefits	140
15.3. Technical Discussion of Protective Measures and Issues	140
15.3.1. Using host based protection	140
15.3.2. User based protection	141
15.3.3. Using interface protection	141
15.3.4. Using a firewall	141
15.3.5. Using a IPC\$ share deny	142
15.3.6. NTLMv2 Security	142
15.4. Upgrading Samba	143
15.5. Common Errors	143
15.5.1. Smbclient works on localhost, but the network is dead	143
15.5.2. Why can users access home directories of other users?	143
16. Interdomain Trust Relationships	144
16.1. Features and Benefits	144
16.2. Trust Relationship Background	144
16.3. Native MS Windows NT4 Trusts Configuration	145
16.3.1. NT4 as the Trusting Domain (ie. creating the trusted account)	145
16.3.2. NT4 as the Trusted Domain (ie. creating trusted account's password)	145
16.4. Configuring Samba NT-style Domain Trusts	145
16.4.1. Samba-3 as the Trusting Domain	145
16.4.2. Samba-3 as the Trusted Domain	146
16.5. Common Errors	147
16.5.1. Tell me about Trust Relationships using Samba	147
17. Hosting a Microsoft Distributed File System tree on Samba	148
17.1. Features and Benefits	148
17.2. Common Errors	149

18. Classical Printing Support	150
18.1. Features and Benefits	150
18.2. Technical Introduction	150
18.2.1. What happens if you send a Job from a Client	151
18.2.2. Printing Related Configuration Parameters	151
18.2.3. Parameters Recommended for Use	151
18.2.4. Parameters for Backwards Compatibility	152
18.2.5. Parameters no longer in use	152
18.3. A simple Configuration to Print with Samba-3	153
18.3.1. Verification of "Settings in Use" with testparm	153
18.3.2. A little Experiment to warn you	154
18.4. Extended Sample Configuration to Print with Samba-3	156
18.5. Detailed Explanation of the Example's Settings	158
18.5.1. The [global] Section	158
18.5.2. The [printers] Section	159
18.5.3. Any [my_printer_name] Section	160
18.5.4. Print Commands	160
18.5.5. Default Print Commands for various Unix Print Subsystems	161
18.5.6. Setting up your own Print Commands	162
18.6. Innovations in Samba Printing since 2.2	163
18.6.1. Client Drivers on Samba Server for <i>Point'n'Print</i>	163
18.6.2. The [printer\$] Section is removed from Samba-3	164
18.6.3. Creating the [print\$] Share	164
18.6.4. Parameters in the [print\$] Section	165
18.6.5. Subdirectory Structure in [print\$]	166
18.7. Installing Drivers into [print\$]	167
18.7.1. Setting Drivers for existing Printers with a Client GUI	167
18.7.2. Setting Drivers for existing Printers with rpcclient	168
18.7.2.1. Identifying the Driver Files	168
18.7.2.2. Collecting the Driver Files from a Windows Host's [print\$] Share	170
18.7.2.3. Depositing the Driver Files into [print\$]	170
18.7.2.4. Check if the Driver Files are there (with smbclient)	171
18.7.2.5. Running rpcclient with adddriver	172
18.7.2.6. Check how Driver Files have been moved after ad- ddriver finished	173
18.7.2.7. Check if the Driver is recognized by Samba	174
18.7.2.8. A sidenote: you are not bound to specific driver names	174
18.7.2.9. La Grande Finale: Running rpcclient with setdriver	175
18.8. "The Proof of the Pudding lies in the Eating" (Client Driver Insta- Procedure)	176
18.8.1. The first Client Driver Installation	176
18.8.2. IMPORTANT! Setting Device Modes on new Printers	177
18.8.3. Further Client Driver Install Procedures	178
18.8.4. Always make first Client Connection as root or "printer admin"	178
18.9. Other Gotchas	179
18.9.1. Setting Default Print Options for the Client Drivers	179
18.9.2. Supporting large Numbers of Printers	180
18.9.3. Adding new Printers with the Windows NT APW	182
18.9.4. Weird Error Message Cannot connect under a different Name	182
18.9.5. Be careful when assembling Driver Files	183
18.9.6. Samba and Printer Ports	186

18.9.7. Avoiding the most common Misconfigurations of the Client Driver	186
18.10 The Imprints Toolset	186
18.10.1. What is Imprints?	186
18.10.2. Creating Printer Driver Packages	187
18.10.3. The Imprints Server	187
18.10.4. The Installation Client	187
18.11 Add Network Printers at Logon without User Interaction	188
18.12 The addprinter command	189
18.13 Migration of "Classical" printing to Samba-3	189
18.14 Publishing Printer Information in Active Directory or LDAP	190
18.15 Common Errors and Problems	190
18.15.1 I give my root password but I don't get access	190
18.15.2 My printjobs get spooled into the spooling directory, but then get lost	190
19. CUPS Printing Support in Samba 3.0	191
19.1. Introduction	191
19.1.1. Features and Benefits	191
19.1.2. Overview	191
19.2. Basic Configuration of CUPS support	191
19.2.1. Linking of smbd with libcups.so	192
19.2.2. Simple smb.conf Settings for CUPS	192
19.2.3. More complex smb.conf Settings for CUPS	193
19.3. Advanced Configuration	194
19.3.1. Central spooling vs. "Peer-to-Peer" printing	194
19.3.2. CUPS/Samba as a "spooling-only" Print Server; "raw" printing with Vendor Drivers on Windows Clients	194
19.3.3. Driver Installation Methods on Windows Clients	195
19.3.4. Explicitly enable "raw" printing for <i>application/octet-stream!</i>	195
19.3.5. Three familiar Methods for driver upload plus a new one	196
19.4. Using CUPS/Samba in an advanced Way – intelligent printing with PostScript Driver Download	196
19.4.1. GDI on Windows – PostScript on Unix	197
19.4.2. Windows Drivers, GDI and EMF	197
19.4.3. Unix Printfile Conversion and GUI Basics	197
19.4.4. PostScript and Ghostscript	199
19.4.5. Ghostscript – the Software RIP for non-PostScript Printers	200
19.4.6. PostScript Printer Description (PPD) Specification	201
19.4.7. CUPS can use all Windows-formatted Vendor PPDs	202
19.4.8. CUPS also uses PPDs for non-PostScript Printers	202
19.5. The CUPS Filtering Architecture	202
19.5.1. MIME types and CUPS Filters	203
19.5.2. MIME type Conversion Rules	204
19.5.3. Filter Requirements	205
19.5.4. Prefilters	205
19.5.5. pstops	206
19.5.6. pstoraster	207
19.5.7. imagetops and imagetoraster	209
19.5.8. rasterto [printerspecific]	209
19.5.9. CUPS Backends	210
19.5.10. cupsomatic/Foomatic – how do they fit into the Picture?	211

19.5.11.	The Complete Picture	212
19.5.12.	mime.convs	212
19.5.13.	”Raw” printing	212
19.5.14.	”application/octet-stream” printing	212
19.5.15.	PostScript Printer Descriptions (PPDs) for non-PS Printers . .	214
19.5.16.	Difference between <i>cupsomatic/foomatic-rip</i> and <i>native CUPS</i> printing	214
19.5.17.	Examples for filtering Chains	215
19.5.18.	Sources of CUPS drivers / PPDs	216
19.5.19.	Printing with Interface Scripts	217
19.6.	Network printing (purely Windows)	217
19.6.1.	From Windows Clients to an NT Print Server	217
19.6.2.	Driver Execution on the Client	217
19.6.3.	Driver Execution on the Server	218
19.7.	Network Printing (Windows clients – UNIX/Samba Print Servers) . .	218
19.7.1.	From Windows Clients to a CUPS/Samba Print Server	218
19.7.2.	Samba receiving Jobfiles and passing them to CUPS	218
19.8.	Network PostScript RIP: CUPS Filters on Server – clients use PostScript Driver with CUPS-PPDs	219
19.8.1.	PPDs for non-PS Printers on UNIX	219
19.8.2.	PPDs for non-PS Printers on Windows	219
19.9.	Windows Terminal Servers (WTS) as CUPS Clients	220
19.9.1.	Printer Drivers running in ”Kernel Mode” cause many Problems	220
19.9.2.	Workarounds impose Heavy Limitations	220
19.9.3.	CUPS: a ”Magical Stone”?	220
19.9.4.	PostScript Drivers with no major problems – even in Kernel Mode	220
19.10.	Setting up CUPS for driver Download	221
19.10.1.	<i>cupsaddsmb</i> : the unknown Utility	221
19.10.2.	Prepare your smb.conf for cupsaddsmb	221
19.10.3.	CUPS Package of ”PostScript Driver for WinNT/2k/XP”	222
19.10.4.	Recognize the different Driver Files	223
19.10.5.	Acquiring the Adobe Driver Files	224
19.10.6.	ESP Print Pro Package of ”PostScript Driver for WinNT/2k/XP”	224
19.10.7.	Caveats to be considered	225
19.10.8.	What are the Benefits of using the ”CUPS PostScript Driver for Windows NT/2k/XP” as compared to the Adobe Driver? . .	226
19.10.9.	Run ”cupsaddsmb” (quiet Mode)	227
19.10.10.	Run ”cupsaddsmb” with verbose Output	228
19.10.11.	Understanding cupsaddsmb	229
19.10.12.	How to recognize if cupsaddsm completed successfully	230
19.10.13.	cupsaddsmb with a Samba PDC	230
19.10.14.	cupsaddsmb Flowchart	230
19.10.15.	Installing the PostScript Driver on a Client	231
19.10.16.	Avoiding critical PostScript Driver Settings on the Client . . .	231
19.11.	Installing PostScript Driver Files manually (using rpcclient)	232
19.11.1.	A Check of the rpcclient man Page	232
19.11.2.	Understanding the rpcclient man Page	233
19.11.3.	Producing an Example by querying a Windows Box	233
19.11.4.	What is required for adddriver and setdriver to succeed	234
19.11.5.	Manual Commandline Driver Installation in 15 little Steps . . .	235
19.11.5.1.	First Step: Install the Printer on CUPS	235

19.11.5.2.	Second Step (optional): Check if the Printer is recognized by Samba	235
19.11.5.3.	Third Step (optional): Check if Samba knows a Driver for the Printer	235
19.11.5.4.	Fourth Step: Put all required Driver Files into Samba's [print\$]	236
19.11.5.5.	Fifth Step: Verify where the Driver Files are now	236
19.11.5.6.	Sixth Step: Tell Samba that these are <i>Driver</i> Files (adddriver)	237
19.11.5.7.	Seventh Step: Verify where the Driver Files are now	237
19.11.5.8.	Eighth Step (optional): Verify if Samba now recognizes the Driver	237
19.11.5.9.	Ninth Step: Tell Samba which Printer should use these Driver Files (setdriver)	238
19.11.5.10.	Tenth Step (optional): Verify if Samba has this Association recognized	238
19.11.5.11.	Eleventh Step (optional): Tickle the Driver into a correct Device Mode	239
19.11.5.12.	Twelveth Step: Install the Printer on a Client ("Point'n'Print")	239
19.11.5.13.	Thirteenth Step (optional): Print a Test Page	239
19.11.5.14.	Fourteenth Step (recommended): Study the Test Page	240
19.11.5.15.	Fifteenth Step (obligatory): Enjoy. Jump. Celebrate your Success	240
19.11.6.	Troubleshooting revisited	240
19.12.	The printing *.tdb Files	241
19.12.1.	Trivial DataBase Files	241
19.12.2.	Binary Format	241
19.12.3.	Losing *.tdb Files	241
19.12.4.	Using <i>tddbbackup</i>	242
19.13.	CUPS Print Drivers from Linuxprinting.org	242
19.13.1.	foomatic-rip and Foomatic explained	243
19.13.1.1.	690 "perfect" Printers	243
19.13.1.2.	How the "Printing HOWTO" started it all	243
19.13.1.3.	Foomatic's strange Name	244
19.13.1.4.	cupsomatic, pdqomatic, lpdomatic, directomatic	244
19.13.1.5.	7.13.1.5.The <i>Grand Unification</i> achieved...	245
19.13.1.6.	Driver Development outside	245
19.13.1.7.	Forums, Downloads, Tutorials, Howtos – also for Mac OS X and commercial Unix	246
19.13.1.8.	Foomatic Database generated PPDs	246
19.13.2.	foomatic-rip and Foomatic-PPD Download and Installation	246
19.14.	Page Accounting with CUPS	248
19.14.1.	Setting up Quotas	249
19.14.2.	Correct and incorrect Accounting	249
19.14.3.	Adobe and CUPS PostScript Drivers for Windows Clients	249
19.14.4.	The page_log File Syntax	249
19.14.5.	Possible Shortcomings	250
19.14.6.	Future Developments	250
19.14.7.	Other Accounting Tools	251
19.15.	Additional Material	251
19.16.	Auto-Deletion or Preservation of CUPS Spool Files	252
19.16.1.	CUPS Configuration Settings explained	252

19.16.2	Pre-conditions	252
19.16.3	Manual Configuration	253
19.17	When <i>not</i> to use Samba to print to CUPS	253
19.18	In Case of Trouble.....	253
19.18.1	Where to find Documentation	253
19.18.2	How to ask for Help	253
19.18.3	Where to find Help	253
19.19	Appendix	254
19.19.1	Printing <i>from</i> CUPS to Windows attached Printers	254
19.19.2	More CUPS filtering Chains	255
19.19.3	Trouble Shooting Guidelines to fix typical Samba printing Problems	261
19.19.4	An Overview of the CUPS Printing Processes	264
20.	Stackable VFS modules	273
20.1.	Features and Benefits	273
20.2.	Discussion	273
20.3.	Included modules	273
20.3.1.	audit	273
20.3.2.	extd_audit	273
20.3.3.	fake_perms	274
20.3.4.	recycle	274
20.3.5.	netatalk	274
20.4.	VFS modules available elsewhere	274
20.4.1.	DatabaseFS	275
20.4.2.	vscan	275
20.5.	Common Errors	275
21.	Integrated Logon Support using Winbind	276
21.1.	Features and Benefits	276
21.2.	Introduction	276
21.3.	What Winbind Provides	276
21.3.1.	Target Uses	277
21.4.	How Winbind Works	277
21.4.1.	Microsoft Remote Procedure Calls	277
21.4.2.	Microsoft Active Directory Services	278
21.4.3.	Name Service Switch	278
21.4.4.	Pluggable Authentication Modules	278
21.4.5.	User and Group ID Allocation	279
21.4.6.	Result Caching	279
21.5.	Installation and Configuration	279
21.5.1.	Introduction	279
21.5.2.	Requirements	280
21.5.3.	Testing Things Out	280
21.5.3.1.	Configure and compile SAMBA	280
21.5.3.2.	Configure nsswitch.conf and the winbind libraries on Linux and Solaris	281
21.5.3.3.	NSS Winbind on AIX	281
21.5.3.4.	Configure smb.conf	282
21.5.3.5.	Join the SAMBA server to the PDC domain	282
21.5.3.6.	Start up the winbindd daemon and test it!	282
21.5.3.7.	Fix the init.d startup scripts	283
21.5.3.8.	Configure Winbind and PAM	286

21.6. Conclusion	289
21.7. Common Errors	289
22. Advanced Network Management	290
22.1. Features and Benefits	290
22.2. Remote Server Administration	290
22.3. Remote Desktop Management	290
22.3.1. Remote Management from NoMachines.Com	290
22.4. Network Logon Script Magic	292
22.4.1. Adding printers without user intervention	294
22.5. Common Errors	294
23. System and Account Policies	295
23.1. Features and Benefits	295
23.2. Creating and Managing System Policies	295
23.2.1. Windows 9x/Me Policies	296
23.2.2. Windows NT4 Style Policy Files	296
23.2.2.1. Registry Spoiling	297
23.2.3. MS Windows 200x / XP Professional Policies	297
23.2.3.1. Administration of Win2K / XP Policies	297
23.3. Managing Account/User Policies	298
23.3.1. Samba Editreg Toolset	299
23.3.2. Windows NT4/200x	299
23.3.3. Samba PDC	299
23.4. System Startup and Logon Processing Overview	299
23.5. Common Errors	300
23.5.1. Policy Does Not Work	300
24. Desktop Profile Management	301
24.1. Features and Benefits	301
24.2. Roaming Profiles	301
24.2.1. Samba Configuration for Profile Handling	301
24.2.1.1. NT4/200x User Profiles	301
24.2.1.2. Windows 9x / Me User Profiles	302
24.2.1.3. Mixed Windows 9x / Me and Windows NT4/200x User Profiles	302
24.2.1.4. Disabling Roaming Profile Support	302
24.2.2. Windows Client Profile Configuration Information	303
24.2.2.1. Windows 9x / Me Profile Setup	303
24.2.2.2. Windows NT4 Workstation	305
24.2.2.3. Windows 2000/XP Professional	305
24.2.3. Sharing Profiles between W9x/Me and NT4/200x/XP work- stations	307
24.2.4. Profile Migration from Windows NT4/200x Server to Samba	308
24.2.4.1. Windows NT4 Profile Management Tools	308
24.2.4.2. Side bar Notes	308
24.2.4.3. moveuser.exe	309
24.2.4.4. Get SID	309
24.3. Mandatory profiles	309
24.4. Creating/Managing Group Profiles	309
24.5. Default Profile for Windows Users	310
24.5.1. MS Windows 9x/Me	310
24.5.1.1. How User Profiles Are Handled in Windows 9x / Me?	310

24.5.2. MS Windows NT4 Workstation	310
24.5.3. MS Windows 200x/XP	312
24.6. Common Errors	314
24.6.1. How does one set up roaming profiles for just one (or a few) user/s or group/s?	314
24.6.2. Can NOT use Roaming Profiles	315
24.6.3. Changing the default profile	315
25. PAM based Distributed Authentication	317
25.1. Features and Benefits	317
25.2. Technical Discussion	318
25.2.1. PAM Configuration Syntax	318
25.2.1.1. Anatomy of /etc/pam.d Entries	319
25.2.2. Example System Configurations	322
25.2.2.1. PAM: original login config	322
25.2.2.2. PAM: login using pam_smbpass	322
25.2.3. smb.conf PAM Configuration	324
25.2.4. Remote CIFS Authentication using winbindd.so	324
25.2.5. Password Synchronization using pam_smbpass.so	325
25.2.5.1. Password Synchronisation Configuration	326
25.2.5.2. Password Migration Configuration	326
25.2.5.3. Mature Password Configuration	327
25.2.5.4. Kerberos Password Integration Configuration	327
25.3. Common Errors	327
25.3.1. pam_winbind problem	327
26. Integrating MS Windows networks with Samba	329
26.1. Features and Benefits	329
26.2. Background Information	329
26.3. Name Resolution in a pure Unix/Linux world	330
26.3.1. /etc/hosts	330
26.3.2. /etc/resolv.conf	331
26.3.3. /etc/host.conf	331
26.3.4. /etc/nsswitch.conf	331
26.4. Name resolution as used within MS Windows networking	332
26.4.1. The NetBIOS Name Cache	333
26.4.2. The LMHOSTS file	333
26.4.3. HOSTS file	335
26.4.4. DNS Lookup	335
26.4.5. WINS Lookup	335
26.5. Common Errors	336
26.5.1. My Boomerang Won't Come Back	336
26.5.2. Very Slow Network Connections	336
26.5.3. Samba server name change problem	336
27. Unicode/Charsets	338
27.1. Features and Benefits	338
27.2. What are charsets and unicode?	338
27.3. Samba and charsets	338
27.4. Conversion from old names	339
27.5. Japanese charsets	339

28. Samba Backup Techniques	340
28.1. Note	340
28.2. Features and Benefits	340
29. High Availability Options	341
29.1. Note	341
IV. Migration and Updating	342
30. Upgrading from Samba-2.x to Samba-3.0.0	343
30.1. Charsets	343
30.2. Obsolete configuration options	343
30.3. Password Backend	343
31. Migration from NT4 PDC to Samba-3 PDC	344
31.1. Planning and Getting Started	344
31.1.1. Objectives	344
31.1.1.1. Domain Layout	345
31.1.1.2. Server Share and Directory Layout	345
31.1.1.3. Logon Scripts	346
31.1.1.4. Profile Migration/Creation	346
31.1.1.5. User and Group Accounts	346
31.1.2. Steps In Migration Process	347
31.2. Migration Options	347
31.2.1. Planning for Success	347
31.2.2. Samba Implementation Choices	348
32. SWAT - The Samba Web Administration Tool	350
32.1. Features and Benefits	350
32.1.1. Enabling SWAT for use	350
32.1.2. Securing SWAT through SSL	351
32.1.3. The SWAT Home Page	352
32.1.4. Global Settings	352
32.1.5. Share Settings	352
32.1.6. Printers Settings	353
32.1.7. The SWAT Wizard	353
32.1.8. The Status Page	353
32.1.9. The View Page	353
32.1.10. The Password Change Page	353
V. Troubleshooting	354
33. The samba checklist	355
33.1. Introduction	355
33.2. Assumptions	355
33.3. The tests	356
33.4. Still having troubles?	359

34. Analysing and solving samba problems	360
34.1. Diagnostics tools	360
34.2. Installing 'Network Monitor' on an NT Workstation or a Windows 9x box	360
34.3. Useful URL's	361
34.4. Getting help from the mailing lists	361
34.5. How to get off the mailinglists	362
35. Reporting Bugs	363
35.1. Introduction	363
35.2. General info	363
35.3. Debug levels	363
35.4. Internal errors	364
35.5. Attaching to a running process	364
35.6. Patches	364
VI. Appendixes	365
36. How to compile SAMBA	366
36.1. Access Samba source code via CVS	366
36.1.1. Introduction	366
36.1.2. CVS Access to samba.org	366
36.1.2.1. Access via CVSweb	366
36.1.2.2. Access via cvs	366
36.2. Accessing the samba sources via rsync and ftp	367
36.3. Verifying Samba's PGP signature	367
36.4. Building the Binaries	367
36.4.1. Compiling samba with Active Directory support	368
36.4.1.1. Installing the required packages for Debian	368
36.4.1.2. Installing the required packages for RedHat	368
36.5. Starting the smbd and nmbd	369
36.5.1. Starting from inetd.conf	369
36.5.2. Alternative: starting it as a daemon	370
36.6. Common Errors	370
37. Portability	371
37.1. HPUX	371
37.2. SCO Unix	371
37.3. DNIX	371
37.4. RedHat Linux Rembrandt-II	372
37.5. AIX	373
37.5.1. Sequential Read Ahead	373
37.6. Solaris	373
37.6.1. Locking improvements	373
37.6.2. Winbind on Solaris 9	373
38. Samba and other CIFS clients	374
38.1. Macintosh clients?	374
38.2. OS2 Client	374
38.2.1. How can I configure OS/2 Warp Connect or OS/2 Warp 4 as a client for Samba?	374

38.2.2. How can I configure OS/2 Warp 3 (not Connect), OS/2 1.2, 1.3 or 2.x for Samba?	375
38.2.3. How do I get printer driver download working for OS/2 clients?	375
38.3. Windows for Workgroups	375
38.3.1. Use latest TCP/IP stack from Microsoft	375
38.3.2. Delete .pwl files after password change	375
38.3.3. Configure WfW password handling	376
38.3.4. Case handling of passwords	376
38.3.5. Use TCP/IP as default protocol	376
38.3.6. Speed improvement	376
38.4. Windows '95/'98	376
38.4.1. Speed improvement	377
38.5. Windows 2000 Service Pack 2	377
38.6. Windows NT 3.1	377
39. Samba Performance Tuning	378
39.1. Comparisons	378
39.2. Socket options	378
39.3. Read size	378
39.4. Max xmit	379
39.5. Log level	379
39.6. Read raw	379
39.7. Write raw	379
39.8. Slow Logins	379
39.9. LDAP	380
39.10 Client tuning	380
39.11 Samba performance problem due changing kernel	380
39.12 Corrupt tdb Files	380
40. DNS and DHCP Configuration Guide	381
40.1. Note	381
41. Further Resources	382
41.1. Websites	382
41.2. Related updates from microsoft	382
41.3. Books	382

Part I.

General Installation

1. Introduction to Samba

“If you understand what you’re doing, you’re not learning anything.” – Anonymous’

Samba is a file and print server for Windows-based clients using TCP/IP as the underlying transport protocol. In fact, it can support any SMB/CIFS-enabled client. One of Samba’s big strengths is that you can use it to blend your mix of Windows and Linux machines together without requiring a separate Windows NT/2000/2003 Server. Samba is actively being developed by a global team of about 30 active programmers and was originally developed by Andrew Tridgell.

1.1. Background

Once long ago, there was a buzzword referred to as DCE/RPC. This stood for Distributed Computing Environment/Remote Procedure Calls and conceptually was a good idea. It was originally developed by Apollo/HP as NCA 1.0 (Network Computing Architecture) and only ran over UDP. When there was a need to run it over TCP so that it would be compatible with DECnet 3.0, it was redesigned, submitted to The Open Group, and officially became known as DCE/RPC. Microsoft came along and decided, rather than pay \$20 per seat to license this technology, to reimplement DCE/RPC themselves as MSRPC. From this, the concept continued in the form of SMB (Server Message Block, or the “what”) using the NetBIOS (Network Basic Input/Output System, or the “how”) compatibility layer. You can run SMB (i.e., transport) over several different protocols; many different implementations arose as a result, including NBIPX (NetBIOS over IPX, NwLknNb, or NWNBLink) and NBT (NetBIOS over TCP/IP, or NetBT). As the years passed, NBT became the most common form of implementation until the advance of “Direct-Hosted TCP” – the Microsoft marketing term for eliminating NetBIOS entirely and running SMB by itself across TCP port 445 only. As of yet, direct-hosted TCP has yet to catch on.

Perhaps the best summary of the origins of SMB are voiced in the 1997 article titled, CIFS: Common Insecurities Fail Scrutiny:

*Several megabytes of NT-security archives, random whitepapers, RFCs, the CIFS spec, the Samba stuff, a few MS knowledge-base articles, strings extracted from binaries, and packet dumps have been dutifully waded through during the information-gathering stages of this project, and there are *still* many missing pieces... While often tedious, at least the way has been generously littered with occurrences of clapping hand to forehead and muttering ‘crikey, what are they thinking?’*

1.2. Terminology

- SMB: Acronym for “Server Message Block”. This is Microsoft’s file and printer sharing protocol.
- CIFS: Acronym for “Common Internet File System”. Around 1996, Microsoft apparently decided that SMB needed the word “Internet” in it, so they changed it to CIFS.
- Direct-Hosted: A method of providing file/printer sharing services over port 445/tcp only using DNS for name resolution instead of WINS.

- IPC: Acronym for "Inter-Process Communication". A method to communicate specific information between programs.
- Marshalling: - A method of serializing (i.e., sequential ordering of) variable data suitable for transmission via a network connection or storing in a file. The source data can be re-created using a similar process called unmarshalling.
- NetBIOS: Acronym for "Network Basic Input/Output System". This is not a protocol; it is a method of communication across an existing protocol. This is a standard which was originally developed for IBM by Sytek in 1983. To exaggerate the analogy a bit, it can help to think of this in comparison your computer's BIOS – it controls the essential functions of your input/output hardware – whereas NetBIOS controls the essential functions of your input/output traffic via the network. Again, this is a bit of an exaggeration but it should help that paradigm shift. What is important to realize is that NetBIOS is a transport standard, not a protocol. Unfortunately, even technically brilliant people tend to interchange NetBIOS with terms like NetBEUI without a second thought; this will cause no end (and no doubt) of confusion.
- NetBEUI: Acronym for the "NetBIOS Extended User Interface". Unlike NetBIOS, NetBEUI is a protocol, not a standard. It is also not routable, so traffic on one side of a router will be unable to communicate with the other side. Understanding NetBEUI is not essential to deciphering SMB; however it helps to point out that it is not the same as NetBIOS and to improve your score in trivia at parties. NetBEUI was originally referred to by Microsoft as "NBF", or "The Windows NT NetBEUI Frame protocol driver". It is not often heard from these days.
- NBT: Acronym for "NetBIOS over TCP"; also known as "NetBT". Allows the continued use of NetBIOS traffic proxied over TCP/IP. As a result, NetBIOS names are made to IP addresses and NetBIOS name types are conceptually equivalent to TCP/IP ports. This is how file and printer sharing are accomplished in Windows 95/98/ME. They traditionally rely on three ports: NetBIOS Name Service (nbname) via UDP port 137, NetBIOS Datagram Service (nbdatagram) via UDP port 138, and NetBIOS Session Service (nbsession) via TCP port 139. All name resolution is done via WINS, NetBIOS broadcasts, and DNS. NetBIOS over TCP is documented in RFC 1001 (Concepts and methods) and RFC 1002 (Detailed specifications).
- W2K: Acronym for Windows 2000 Professional or Server
- W3K: Acronym for Windows 2003 Server

If you plan on getting help, make sure to subscribe to the Samba Mailing List (available at <http://www.samba.org>).

1.3. Related Projects

There are currently two network filesystem client projects for Linux that are directly related to Samba: SMBFS and CIFS VFS. These are both available in the Linux kernel itself.

- SMBFS (Server Message Block File System) allows you to mount SMB shares (the protocol that Microsoft Windows and OS/2 Lan Manager use to share files and printers over local networks) and access them just like any other Unix directory. This is useful if you just want to mount such filesystems without being a SMBFS server.
- CIFS VFS (Common Internet File System Virtual File System) is the successor to SMBFS, and is being actively developed for the upcoming version of the Linux kernel. The intent of this module is to provide advanced network

file system functionality including support for dfs (heirarchical name space), secure per-user session establishment, safe distributed caching (oplock), optional packet signing, Unicode and other internationalization improvements, and optional Winbind (nsswitch) integration.

Again, it's important to note that these are implementations for client filesystems, and have nothing to do with acting as a file and print server for SMB/CIFS clients.

There are other Open Source CIFS client implementations, such as the [jCIFS project](#) which provides an SMB client toolkit written in Java.

1.4. SMB Methodology

Traditionally, SMB uses UDP port 137 (NetBIOS name service, or netbios-ns), UDP port 138 (NetBIOS datagram service, or netbios-dgm), and TCP port 139 (NetBIOS session service, or netbios-ssn). Anyone looking at their network with a good packet sniffer will be amazed at the amount of traffic generated by just opening up a single file. In general, SMB sessions are established in the following order:

- "TCP Connection" - establish 3-way handshake (connection) to port 139/tcp or 445/tcp.
- "NetBIOS Session Request" - using the following "Calling Names": The local machine's NetBIOS name plus the 16th character 0x00; The server's NetBIOS name plus the 16th character 0x20
- "SMB Negotiate Protocol" - determine the protocol dialect to use, which will be one of the following: PC Network Program 1.0 (Core) - share level security mode only; Microsoft Networks 1.03 (Core Plus) - share level security mode only; Lanman1.0 (LAN Manager 1.0) - uses Challenge/Response Authentication; Lanman2.1 (LAN Manager 2.1) - uses Challenge/Response Authentication; NT LM 0.12 (NT LM 0.12) - uses Challenge/Response Authentication
- SMB Session Startup. Passwords are encrypted (or not) according to one of the following methods: Null (no encryption); Cleartext (no encryption); LM and NTLM; NTLM; NTLMv2
- SMB Tree Connect: Connect to a share name (e.g., \\servername\share); Connect to a service type (e.g., IPC\$ named pipe)

A good way to examine this process in depth is to try out [SecurityFriday's SWB program](#). It allows you to walk through the establishment of a SMB/CIFS session step by step.

1.5. Epilogue

'What's fundamentally wrong is that nobody ever had any taste when they did it. Microsoft has been very much into making the user interface look good, but internally it's just a complete mess. And even people who program for Microsoft and who have had years of experience, just don't know how it works internally. Worse, nobody dares change it. Nobody dares to fix bugs because it's such a mess that fixing one bug might just break a hundred programs that depend on that bug. And Microsoft isn't interested in anyone fixing bugs - they're interested in making money. They don't have anybody who takes pride in Windows 95 as an operating system.'

'People inside Microsoft know it's a bad operating system and they still continue obviously working on it because they want to get the next version out because they want to have all these new features to sell more copies of the system.'

'The problem with that is that over time, when you have this kind of approach, and because nobody understands it, because nobody REALLY fixes bugs (other than

when they're really obvious), the end result is really messy. You can't trust it because under certain circumstances it just spontaneously reboots or just halts in the middle of something that shouldn't be strange. Normally it works fine and then once in a blue moon for some completely unknown reason, it's dead, and nobody knows why. Not Microsoft, not the experienced user and certainly not the completely clueless user who probably sits there shivering thinking "What did I do wrong?" when they didn't do anything wrong at all.'

'That's what's really irritating to me.'

– [Linus Torvalds, from an interview with BOOT Magazine, Sept 1998](#)

1.6. Miscellaneous

This chapter is Copyright 2003 David Lechnyr (david at lechnyr dot com). Permission is granted to copy, distribute and/or modify this document under the terms of the GNU Free Documentation License, Version 1.2 or any later version published by the Free Software Foundation. A copy of the license is available at <http://www.gnu.org/licenses/fdl.txt>.

2. How to Install and Test SAMBA

2.1. Obtaining and installing samba

Binary packages of samba are included in almost any Linux or Unix distribution. There are also some packages available at [the samba homepage](#).

If you need to compile samba from source, check the [appropriate appendix chapter](#).

If you have already installed samba, or if your operating system was pre-installed with samba, then you may not need to bother with this chapter. On the other hand, you may want to read this chapter anyhow for information about updating samba.

2.2. Configuring samba (smb.conf)

Samba's configuration is stored in the `smb.conf` file, that usually resides in `/etc/samba/smb.conf` or `/usr/local/samba/lib/smb.conf`. You can either edit this file yourself or do it using one of the many graphical tools that are available, such as the web-based interface `swat`, that is included with samba.

2.2.1. Example Configuration

There are sample configuration files in the `examples` subdirectory in the distribution. I suggest you read them carefully so you can see how the options go together in practice. See the man page for all the options.

The simplest useful configuration file would be something like this:

```
[global]
    workgroup = MYGROUP

[homes]
    guest ok = no
    read only = no
```

This will allow connections by anyone with an account on the server, using either their login name or "homes" as the service name. (Note that the workgroup that Samba must also be set.)

Make sure you put the `smb.conf` file in the same place you specified in the `Makefile` (the default is to look for it in `/usr/local/samba/lib/`).

For more information about security settings for the `[homes]` share please refer to the chapter [Securing Samba](#).

2.2.1.1. Test your config file with testparm

It's important that you test the validity of your `smb.conf` file using the `testparm` program. If `testparm` runs OK then it will list the loaded services. If not it will give an error message.

Make sure it runs OK and that the services look reasonable before proceeding.

Always run `testparm` again when you change `smb.conf`!

2.2.2. SWAT

SWAT is a web-based interface that helps you configure samba. SWAT might not be available in the samba package on your platform, but in a separate package. Please read the swat manpage on compiling, installing and configuring swat from source.

To launch SWAT just run your favorite web browser and point it at <http://localhost:901/>. Replace localhost with the name of the computer you are running samba on if you are running samba on a different computer than your browser.

Note that you can attach to SWAT from any IP connected machine but connecting from a remote machine leaves your connection open to password sniffing as passwords will be sent in the clear over the wire.

2.3. Try listing the shares available on your server

```
$smbclient -L yourhostname
```

You should get back a list of shares available on your server. If you don't then something is incorrectly setup. Note that this method can also be used to see what shares are available on other LanManager clients (such as WfWg).

If you choose user level security then you may find that Samba requests a password before it will list the shares. See the **smbclient** man page for details. (you can force it to list the shares without a password by adding the option `-U%` to the command line. This will not work with non-Samba servers)

2.4. Try connecting with the unix client

```
$smbclient //yourhostname/aservice
```

Typically the yourhostname would be the name of the host where you installed `smbd`. The aservice is any service you have defined in the `smb.conf` file. Try your user name if you just have a `[homes]` section in `smb.conf`.

For example if your unix host is bambi and your login name is fred you would type:

```
$smbclient //bambi/fred
```

2.5. Try connecting from a DOS, WfWg, Win9x, WinNT, Win2k, OS/2, etc... client

Try mounting disks. eg:

```
C:\WINDOWS\>net use d: \\servername\service
```

Try printing. eg:

```
C:\WINDOWS\>net use lpt1: \\servername\spoolservice
```

```
C:\WINDOWS\>print filename
```

2.6. What If Things Don't Work?

Then you might read the file chapter [Diagnosis](#) and the [FAQ](#). If you are still stuck then try to follow the [Analysing and Solving Problems](#) chapter Samba has been successfully installed at thousands of sites worldwide, so maybe someone else has hit your problem and has overcome it.

2.7. Common Errors

The following questions and issues get raised on the samba mailing list over and over again.

2.7.1. Why are so many smbd processes eating memory?

‘Site that is running Samba on an AIX box. They are sharing out about 2 terabytes using samba. Samba was installed using smitty and the binaries. We seem to be experiencing a memory problem with this box. When I do a `svmon -Pu` the monitoring program shows that smbd has several processes of smbd running:’

‘Is samba suppose to start this many different smbd processes? Or does it run as one smbd process? Also is it normal for it to be taking up this much memory?’

Inuse * 4096 = amount of memory being used by this process

Pid	Command	Inuse	Pin	Pgsp	Virtual	64-bit	Mthrd
20950	smbd	33098	1906	181	5017	N	N
22262	smbd	9104	1906	5410			
21060	smbd	9048	1906	181	5479	N	N
25972	smbd	8678	1906	181	5109	N	N
24524	smbd	8674	1906	181	5105	N	N
19262	smbd	8582	1906	181	5013	N	N
20722	smbd	8572	1906	181	5003	N	N
21454	smbd	8572	1906	181	5003	N	N
28946	smbd	8567	1906	181	4996	N	N
24076	smbd	8566	1906	181	4996	N	N
20138	smbd	8566	1906	181	4996	N	N
17608	smbd	8565	1906	181	4996	N	N
21820	smbd	8565	1906	181	4996	N	N
26940	smbd	8565	1906	181	4996	N	N
19884	smbd	8565	1906	181	4996	N	N
9912	smbd	8565	1906	181	4996	N	N
25800	smbd	8564	1906	181	4995	N	N
20452	smbd	8564	1906	181	4995	N	N
18592	smbd	8562	1906	181	4993	N	N
28216	smbd	8521	1906	181	4954	N	N
19110	smbd	8404	1906	181	4862	N	N

Total memory used: 841,592,832 bytes

Samba consists on three core programs: nmbd, smbd, winbindd. nmbd is the name server message daemon, smbd is the server message daemon, winbindd is the daemon that handles communication with Domain Controllers.

If your system is NOT running as a WINS server, then there will be one (1) single instance of nmbd running on your system. If it is running as a WINS server then there will be two (2) instances - one to handle the WINS requests.

smbd handles ALL connection requests and then spawns a new process for each client connection made. That is why you are seeing so many of them, one (1) per client connection.

winbindd will run as one or two daemons, depending on whether or not it is being run in "split mode" (in which case there will be two instances).

2.7.2. I'm getting "open_oplock_ipc: Failed to get local UDP socket for address 100007f. Error was Cannot assign requested" in the logs

Your loopback device isn't working correctly. Make sure it's running.

3. FastStart for the Impatient

3.1. Note

This chapter did not make it into this release. It is planned for the published release of this document.

Part II.

Server Configuration Basics

4. Server Types and Security Modes

This chapter provides information regarding the types of server that Samba may be configured to be. A Microsoft network administrator who wishes to migrate to or to use Samba will want to know what, within a Samba context, terms familiar to MS Windows administrator mean. This means that it is essential also to define how critical security modes function BEFORE we get into the details of how to configure the server itself.

The chapter provides an overview of the security modes of which Samba is capable and how these relate to MS Windows servers and clients.

Firstly we should recognise the question so often asked, "Why would I want to use Samba?" So, in those chapters where the answer may be important you will see a section that highlights features and benefits. These may be for or against Samba.

4.1. Features and Benefits

Two men were walking down a dusty road, when one suddenly kicked up a small red stone. It hurt his toe and lodged in his saddle. He took the stone out and cursed it with a passion and fury fitting his anguish. The other looked at the stone and said, that is a garnet - I can turn that into a precious gem and some day it will make a princess very happy!

The moral of this tale: Two men, two very different perspectives regarding the same stone. Like it or not, Samba is like that stone. Treat it the right way and it can bring great pleasure, but if you are forced upon it and have no time for its secrets then it can be a source of discomfort.

Samba started out as a project that sought to provide interoperability for MS Windows 3.x clients with a Unix server. It has grown up a lot since its humble beginnings and now provides features and functionality fit for large scale deployment. It also has some warts. In sections like this one we will tell of both.

So now, what are the benefits of features mentioned in this chapter?

- Samba-3 can replace an MS Windows NT4 Domain Controller
- Samba-3 offers excellent interoperability with MS Windows NT4 style domains as well as natively with Microsoft Active Directory domains.
- Samba-3 permits full NT4 style Interdomain Trusts
- Samba has security modes that permit more flexible authentication than is possible with MS Windows NT4 Domain Controllers.
- Samba-3 permits use of multiple account database backends
- The account (password) database backends can be distributed and replicated using multiple methods. This gives Samba-3 greater flexibility than MS Windows NT4 and in many cases a significantly higher utility than Active Directory domains with MS Windows 200x.

4.2. Server Types

Administrators of Microsoft networks often refer to three different type of servers:

- Domain Controller

- Primary Domain Controller
- Backup Domain Controller
- ADS Domain Controller

- Domain Member Server
 - Active Directory Member Server
 - NT4 Style Domain Member Server
- Stand Alone Server

The chapters covering Domain Control, Backup Domain Control and Domain Membership provide pertinent information regarding Samba-3 configuration for each of these server roles. The reader is strongly encouraged to become intimately familiar with the information presented.

4.3. Samba Security Modes

In this section the function and purpose of Samba's security modes are described. An accurate understanding of how Samba implements each security mode as well as how to configure MS Windows clients for each mode will significantly reduce user complaints and administrator heartache.

In the SMB/CIFS networking world, there are only two types of security: *USER Level* and *SHARE Level*. We refer to these collectively as *security levels*. In implementing these two *security levels* Samba provides flexibilities that are not available with Microsoft Windows NT4 / 200x servers. Samba knows of five (5) ways that allow the security levels to be implemented. In actual fact, Samba implements *SHARE Level* security only one way, but has four ways of implementing *USER Level* security. Collectively, we call the Samba implementations *Security Modes*. These are: *SHARE*, *USER*, *DOMAIN*, *ADS*, and *SERVER* modes. They are documented in this chapter.

A SMB server tells the client at startup what security level it is running. There are two options: *share level* and *user level*. Which of these two the client receives affects the way the client then tries to authenticate itself. It does not directly affect (to any great extent) the way the Samba server does security. This may sound strange, but it fits in with the client/server approach of SMB. In SMB everything is initiated and controlled by the client, and the server can only tell the client what is available and whether an action is allowed.

4.3.1. User Level Security

We will describe user level security first, as it's simpler. In *user level* security, the client will send a *session setup* command directly after the protocol negotiation. This contains a username and password. The server can either accept or reject that username/password combination. Note that at this stage the server has no idea what share the client will eventually try to connect to, so it can't base the *accept/reject* on anything other than:

1. The username/password
2. The name of the client machine

If the server accepts the username/password then the client expects to be able to mount shares (using a *tree connection*) without specifying a password. It expects that all access rights will be as the username/password specified in the *session setup*.

It is also possible for a client to send multiple *session setup* requests. When the server responds, it gives the client a *uid* to use as an authentication tag for that

username/password. The client can maintain multiple authentication contexts in this way (WinDD is an example of an application that does this).

4.3.1.1. Example Configuration

The `smb.conf` parameter that sets *User Level Security* is:

```
security = user
```

This is the default setting since samba-2.2.x.

4.3.2. Share Level Security

Ok, now for share level security. In share level security, the client authenticates itself separately for each share. It will send a password along with each *tree connection* (share mount). It does not explicitly send a username with this operation. The client expects a password to be associated with each share, independent of the user. This means that Samba has to work out what username the client probably wants to use. It is never explicitly sent the username. Some commercial SMB servers such as NT actually associate passwords directly with shares in share level security, but Samba always uses the unix authentication scheme where it is a username/password pair that is authenticated, not a share/password pair.

To gain understanding of the MS Windows networking parallels to this, one should think in terms of MS Windows 9x/Me where one can create a shared folder that provides read-only or full access, with or without a password.

Many clients send a *session setup* even if the server is in share level security. They normally send a valid username but no password. Samba records this username in a list of *possible usernames*. When the client then does a *tree connection* it also adds to this list the name of the share they try to connect to (useful for home directories) and any users listed in the `user = smb.conf` line. The password is then checked in turn against these *possible usernames*. If a match is found then the client is authenticated as that user.

4.3.2.1. Example Configuration

The `smb.conf` parameter that sets *Share Level Security* is:

```
security = share
```

Please note that there are reports that recent MS Windows clients do not like to work with share mode security servers. You are strongly discouraged from using share level security.

4.3.3. Domain Security Mode (User Level Security)

When Samba is operating in `security = domain` mode, the Samba server has a domain security trust account (a machine account) and will cause all authentication requests to be passed through to the domain controllers.

4.3.3.1. Example Configuration

Samba as a Domain Member Server

This method involves addition of the following parameters in the `smb.conf` file:

```
security = domain
workgroup = "name_of_NT_domain"
```

In order for this method to work, the Samba server needs to join the MS Windows NT security domain. This is done as follows:

1. On the MS Windows NT domain controller, using the Server Manager, add a machine account for the Samba server.
2. Next, on the Unix/Linux system execute:`root#smbpasswd -j DOMAIN_NAME -r PDC_NAME (samba-2.x)root#net join -U administrator%password (samba-3)`

NOTE

As of Samba-2.2.4 the Samba 2.2.x series can auto-join a Windows NT4 style Domain just by executing:

```
root# smbpasswd -j DOMAIN_NAME -r PDC_NAME -U Administrator%password
```



As of Samba-3 the same can be done by executing:

```
root# net join -U Administrator%password
```

It is not necessary with Samba-3 to specify the `DOMAIN_NAME` or the `PDC_NAME` as it figures this out from the `smb.conf` file settings.

Use of this mode of authentication does require there to be a standard Unix account for each user in order to assign a uid once the account has been authenticated by the remote Windows DC. This account can be blocked to prevent logons by clients other than MS Windows through things such as setting an invalid shell in the `/etc/passwd` entry.

An alternative to assigning UIDs to Windows users on a Samba member server is presented in the [Winbind Overview](#) chapter in this HOWTO collection.

For more information of being a domain member, see the [Domain Member](#) section of this Howto.

4.3.4. ADS Security Mode (User Level Security)

Both Samba 2.2 and 3.0 can join an Active Directory domain. This is possible even if the domain is run in native mode. Active Directory in native mode perfectly allows NT4-style domain members, contrary to popular belief. The only thing that Active Directory in native mode prohibits is Backup Domain Controllers running NT4.

If you are running Active Directory starting with Samba 3.0 you can however join as a native AD member. Why would you want to do that? Your security policy might prohibit the use of NT-compatible authentication protocols. All your machines are running Windows 2000 and above and all use full Kerberos. In this case Samba as a NT4-style domain would still require NT-compatible authentication data. Samba

in AD-member mode can accept Kerberos.

4.3.4.1. Example Configuration

```
realm = your.kerberos.REALM
security = ADS
```

The following parameter may be required:

```
ads server = your.kerberos.server
```

Please refer to the [Domain Membership](#) and [Active Directory Membership](#) sections for more information regarding this configuration option.

4.3.5. Server Security (User Level Security)

Server security mode is a left over from the time when Samba was not capable of acting as a domain member server. It is highly recommended NOT to use this feature. Server security mode has many draw backs. The draw backs include:

- Potential Account Lockout on MS Windows NT4/200x password servers
- Lack of assurance that the password server is the one specified
- Does not work with Winbind, particularly needed when storing profiles remotely
- This mode may open connections to the password server, and keep them open for extended periods.
- Security on the Samba server breaks badly when the remote password server suddenly shuts down
- With this mode there is NO security account in the domain that the password server belongs to for the Samba server.

In server security mode the Samba server reports to the client that it is in user level security. The client then does a *session setup* as described earlier. The Samba server takes the username/password that the client sends and attempts to login to the password server by sending exactly the same username/password that it got from the client. If that server is in user level security and accepts the password, then Samba accepts the clients connection. This allows the Samba server to use another SMB server as the password server.

You should also note that at the very start of all this, where the server tells the client what security level it is in, it also tells the client if it supports encryption. If it does then it supplies the client with a random cryptkey. The client will then send all passwords in encrypted form. Samba supports this type of encryption by default.

The parameter `security = server` means that Samba reports to clients that it is running in *user mode* but actually passes off all authentication requests to another *user mode* server. This requires an additional parameter `password server` that points to the real authentication server. That real authentication server can be another Samba server or can be a Windows NT server, the later natively capable of encrypted password support.

NOTE



When Samba is running in *server security mode* it is essential that the parameter *password server* is set to the precise NetBIOS machine name of the target authentication server. Samba can NOT determine this from NetBIOS name lookups because the choice of the target authentication server is arbitrary and can not be determined from a domain name. In essence, a Samba server that is in *server security mode* is operating in what used to be known as workgroup mode.

4.3.5.1. Example Configuration

Using MS Windows NT as an authentication server

This method involves the additions of the following parameters in the `smb.conf` file:

```
encrypt passwords = Yes
security = server
password server = "NetBIOS_name_of_a_DC"
```

There are two ways of identifying whether or not a username and password pair was valid or not. One uses the reply information provided as part of the authentication messaging process, the other uses just an error code.

The down-side of this mode of configuration is the fact that for security reasons Samba will send the password server a bogus username and a bogus password and if the remote server fails to reject the username and password pair then an alternative mode of identification of validation is used. Where a site uses password lock out after a certain number of failed authentication attempts this will result in user lockouts.

Use of this mode of authentication does require there to be a standard Unix account for the user, though this account can be blocked to prevent logons by non-SMB/CIFS clients.

4.4. Seamless Windows Network Integration

MS Windows clients may use encrypted passwords as part of a challenge/response authentication model (a.k.a. NTLMv1 and NTLMv2) or alone, or clear text strings for simple password based authentication. It should be realized that with the SMB protocol, the password is passed over the network either in plain text or encrypted, but not both in the same authentication request.

When encrypted passwords are used, a password that has been entered by the user is encrypted in two ways:

- An MD4 hash of the UNICODE of the password string. This is known as the NT hash.
- The password is converted to upper case, and then padded or truncated to 14 bytes. This string is then appended with 5 bytes of NULL characters and split to form two 56 bit DES keys to encrypt a "magic" 8 byte value. The resulting 16 bytes form the LanMan hash.

MS Windows 95 pre-service pack 1, MS Windows NT versions 3.x and version 4.0 pre-service pack 3 will use either mode of password authentication. All versions of

MS Windows that follow these versions no longer support plain text passwords by default.

MS Windows clients have a habit of dropping network mappings that have been idle for 10 minutes or longer. When the user attempts to use the mapped drive connection that has been dropped, the client re-establishes the connection using a cached copy of the password.

When Microsoft changed the default password mode, support was dropped for caching of the plain text password. This means that when the registry parameter is changed to re-enable use of plain text passwords it appears to work, but when a dropped service connection mapping attempts to revalidate it will fail if the remote authentication server does not support encrypted passwords. This means that it is definitely not a good idea to re-enable plain text password support in such clients.

The following parameters can be used to work around the issue of Windows 9x clients upper casing usernames and password before transmitting them to the SMB server when using clear text authentication.

```
password level = integer
username level = integer
```

By default Samba will lower case the username before attempting to lookup the user in the database of local system accounts. Because UNIX usernames conventionally only contain lower case character, the username level parameter is rarely needed.

However, passwords on UNIX systems often make use of mixed case characters. This means that in order for a user on a Windows 9x client to connect to a Samba server using clear text authentication, the password level must be set to the maximum number of upper case letter which *could* appear in a password. Note that the server OS uses the traditional DES version of `crypt()`, a password level of 8 will result in case insensitive passwords as seen from Windows users. This will also result in longer login times as Samba has to compute the permutations of the password string and try them one by one until a match is located (or all combinations fail).

The best option to adopt is to enable support for encrypted passwords where ever Samba is used. Most attempts to apply the registry change to re-enable plain text passwords will eventually lead to user complaints and unhappiness.

4.5. Common Errors

We all make mistakes. It is Ok to make mistakes, so long as they are made in the right places and at the right time. A mistake that causes lost productivity is seldom tolerated. A mistake made in a developmental test lab is expected.

Here we look at common mistakes and misapprehensions that have been the subject of discussions on the Samba mailing lists. Many of these are avoidable by doing you homework before attempting a Samba implementation. Some are the result of misunderstanding of the English language. The English language has many turns of phrase that are potentially vague and may be highly confusing to those for whom English is not their native tongue.

4.5.1. What makes Samba a SERVER?

To some the nature of the Samba *security* mode is very obvious, but entirely wrong all the same. It is assumed that security = server means that Samba will act as a

server. Not so! See above - this setting means that Samba will *try* to use another SMB server as its source of user authentication alone.

4.5.2. What makes Samba a Domain Controller?

The `smb.conf` parameter `security = domain` does NOT really make Samba behave as a Domain Controller! This setting means we want Samba to be a domain member!

4.5.3. What makes Samba a Domain Member?

Guess! So many others do. But whatever you do, do NOT think that `security = user` makes Samba act as a domain member. Read the manufacturers manual before the warranty expires! See the [Domain Member](#) section of this Howto for more information.

4.5.4. Constantly Losing Connections to Password Server

Why does `server_validate()` simply give up rather than re-establishing its connection to the password server? Though I am not fluent in the SMB protocol, perhaps the cluster server process passes along to its client workstation the session key it receives from the password server, which means the password hashes submitted by the client would not work on a subsequent connection, whose session key would be different. So `server_validate()` must give up.

Indeed. That's why `security = server` is at best a nasty hack. Please use `security = domain`. `security = server` mode is also known as pass-through authentication.

5. Domain Control

The Essence of Learning: There are many who approach MS Windows networking with incredible misconceptions. That's OK, because it gives the rest of us plenty of opportunity to be of assistance. Those who really want help would be well advised to become familiar with information that is already available.

The reader is advised NOT to tackle this section without having first understood and mastered some basics. MS Windows networking is not particularly forgiving of misconfiguration. Users of MS Windows networking are likely to complain bitterly of persistent niggles that may be caused by broken network or system configuration. To a great many people however, MS Windows networking starts with a domain controller that in some magical way is expected to solve all ills.

From the Samba mailing list one can readily identify many common networking issues. If you are not clear on the following subjects, then it will do much good to read the sections of this HOWTO that deal with it. These are the most common causes of MS Windows networking problems:

- Basic TCP/IP configuration
- NetBIOS name resolution
- Authentication configuration
- User and Group configuration
- Basic File and Directory Permission Control in Unix/Linux
- Understanding of how MS Windows clients interoperate in a network environment

Do not be put off; on the surface of it MS Windows networking seems so simple that any fool can do it. In fact, it is not a good idea to set up an MS Windows network with inadequate training and preparation. But let's get our first indelible principle out of the way: *It is perfectly OK to make mistakes!* In the right place and at the right time, mistakes are the essence of learning. It is *very much* not ok to make mistakes that cause loss of productivity and impose an avoidable financial burden on an organisation.

Where is the right place to make mistakes? Only out of harm's way! If you are going to make mistakes, then please do this on a test network, away from users and in such a way as to not inflict pain on others. Do your learning on a test network.

5.1. Features and Benefits

What is the key benefit of Microsoft Domain security?

In a word, *Single Sign On*, or SSO for short. To many, this is the holy grail of MS Windows NT and beyond networking. SSO allows users in a well designed network to log onto any workstation that is a member of the domain that their user account is in (or in a domain that has an appropriate trust relationship with the domain they are visiting) and they will be able to log onto the network and access resources (shares, files, and printers) as if they are sitting at their home (personal) workstation. This is a feature of the Domain security protocols.

The benefits of Domain security are fully available to those sites that deploy a Samba PDC.

NOTE



Network clients of an MS Windows Domain security environment must be Domain members to be able to gain access to the advanced features provided. Domain membership involves more than just setting the workgroup name to the Domain name. It requires the creation of a Domain trust account for the workstation (called a machine account). Please refer to the chapter on [Domain Membership](#) for more information.

The following functionalities are new to the Samba-3 release:

- Windows NT4 domain trusts
- Adding users via the User Manager for Domains. This can be done on any MS Windows client using the Nexus toolkit that is available from Microsoft's web site. At some later date Samba-3 may get support for the use of the Microsoft Management Console for user management.
- Introduces replaceable and multiple user account (authentication) back ends. In the case where the back end is placed in an LDAP database, Samba-3 confers the benefits of a back end that can be distributed, replicated, and is highly scalable.
- Implements full Unicode support. This simplifies cross locale internationalisation support. It also opens up the use of protocols that Samba-2.2.x had but could not use due to the need to fully support Unicode.

The following functionalities are NOT provided by Samba-3:

- SAM replication with Windows NT4 Domain Controllers (i.e. a Samba PDC and a Windows NT BDC or vice versa)
- Acting as a Windows 2000 Domain Controller (i.e. Kerberos and Active Directory) - In point of fact, Samba-3 DOES have some Active Directory Domain Control ability that is at this time purely experimental *AND* that is certain to change as it becomes a fully supported feature some time during the Samba-3 (or later) life cycle.

Windows 9x / Me / XP Home clients are not true members of a domain for reasons outlined in this chapter. The protocol for support of Windows 9x / Me style network (domain) logons is completely different from NT4 / Win2k type domain logons and has been officially supported for some time. These clients use the old LanMan Network Logon facilities that are supported in Samba since approximately the Samba-1.9.15 series.

Samba-3 has an implementation of group mapping between Windows NT groups and Unix groups (this is really quite complicated to explain in a short space). This is discussed more fully in the [Group Mapping](#) chapter.

Samba-3, like an MS Windows NT4 PDC or a Windows 200x Active Directory, needs to store user and machine trust account information in a suitable backend data store. With Samba-3 there can be multiple back-ends for this including:

- *smbpasswd* - the plain ascii file stored used by earlier versions of Samba. This file configuration option requires a Unix/Linux system account for EVERY entry (ie: both for user and for machine accounts). This file will be located in the *private* directory (default is `/usr/local/samba/lib/private` or on linux `/etc/samba`).

- *tdbsam* - a binary database backend that will be stored in the *private* directory in a file called *passdb.tdb*. The key benefit of this binary format file is that it can store binary objects that can not be accommodated in the traditional plain text *smbpasswd* file. These permit the extended account controls that MS Windows NT4 and later also have.
- *ldapsam* - An LDAP based back-end. Permits the LDAP server to be specified. eg: `ldap://localhost` or `ldap://frodo.murphy.com`. Like the *tdbsam*, *ldapsam* permits the storing of extended account attributes for control of things like: Permitted access times, password activation and expiry, permitted points of access (workstation names), per user profile location, and much more.
- *ldapsam_compat* - An LDAP back-end that maintains backwards compatibility with the behaviour of *samba-2.2.x*. You should use this in the process of migrating from *samba-2.2.x* to *samba-3* if you do not want to rebuild your LDAP database.

Read the chapter about [Account Information Database](#) for details regarding the choices available and how to configure them.

NOTE

The new *tdbsam* and *ldapsam* account backends store substantially more information than *smbpasswd* is capable of. The new backend database includes capacity to specify per user settings for many parameters, over-riding global settings given in the *smb.conf* file. eg: *logon drive*, *logon home*, *logon path*, etc. Thus, with *samba-3* it is possible to have a default system configuration for profiles, and on a per user basis to over-ride this for those users who should not be subject to the default configuration.

5.2. Basics of Domain Control

Over the years, public perceptions of what Domain Control really is has taken on an almost mystical nature. Before we branch into a brief overview of Domain Control, there are three basic types of domain controllers:

5.2.1. Domain Controller Types

- Primary Domain Controller
- Backup Domain Controller
- ADS Domain Controller

The *Primary Domain Controller* or PDC plays an important role in the MS Windows NT4 and Windows 200x Domain Control architecture, but not in the manner that so many expect. There is folk lore that dictates that because of it's role in the MS Windows network, the PDC should be the most powerful and most capable machine in the network. As strange as it may seem to say this here, good over all network performance dictates that the entire infrastructure needs to be balanced. It is advisable to invest more in the Backup Domain Controllers and Stand-Alone (or Domain Member) servers than in the PDC.

In the case of MS Windows NT4 style domains, it is the PDC seeds the Domain Control database, a part of the Windows registry called the SAM (Security

Account Manager). It plays a key part in NT4 type domain user authentication and in synchronisation of the domain authentication database with Backup Domain Controllers.

With MS Windows 200x Server based Active Directory domains, one domain controller seeds a potential hierarchy of domain controllers, each with their own area of delegated control. The master domain controller has the ability to override any down-stream controller, but a down-line controller has control only over its down-line. With Samba-3 this functionality can be implemented using an LDAP based user and machine account back end.

New to Samba-3 is the ability to use a back-end database that holds the same type of data as the NT4 style SAM (Security Account Manager) database (one of the registry files). The Samba-3 SAM can be specified via the `smb.conf` file parameter `passwd backend` and valid options include `smbpasswd`, `tdbsam`, `ldapsam`, `nisplussam`, `xmllsam`, `mysqllsam`, `guest`.

The *Backup Domain Controller* or BDC plays a key role in servicing network authentication requests. The BDC is biased to answer logon requests in preference to the PDC. On a network segment that has a BDC and a PDC the BDC will be most likely to service network logon requests. The PDC will answer network logon requests when the BDC is too busy (high load). A BDC can be promoted to a PDC. If the PDC is on line at the time that a BDC is promoted to PDC, the previous PDC is automatically demoted to a BDC. With Samba-3 this is NOT an automatic operation; the PDB and BDC must be manually configured and changes need to be made likewise.

With MS Windows NT4, it is an install time decision what type of machine the server will be. It is possible to change the promote a BDC to a PDC and vice versa only, but the only way to convert a domain controller to a domain member server or a stand-alone server is to reinstall it. The install time choices offered are:

- *Primary Domain Controller* - The one that seeds the domain SAM
- *Backup Domain Controller* - One that obtains a copy of the domain SAM
- *Domain Member Server* - One that has NO copy of the domain SAM, rather it obtains authentication from a Domain Controller for all access controls.
- *Stand-Alone Server* - One that plays NO part in SAM synchronisation, has its own authentication database and plays no role in Domain security.

With MS Windows 2000 the configuration of domain control is done after the server has been installed. Samba-3 is capable of acting fully as a native member of a Windows 200x server Active Directory domain.

New to Samba-3 is the ability to function fully as an MS Windows NT4 style Domain Controller, excluding the SAM replication components. However, please be aware that Samba-3 support the MS Windows 200x domain control protocols also.

At this time any appearance that Samba-3 is capable of acting as an *ADS Domain Controller* is limited and experimental in nature. This functionality should not be used until the Samba-Team offers formal support for it. At such a time, the documentation will be revised to duly reflect all configuration and management requirements.

5.2.2. Preparing for Domain Control

There are two ways that MS Windows machines may interact with each other, with other servers, and with Domain Controllers: Either as *Stand-Alone* systems, more commonly called *Workgroup* members, or as full participants in a security system, more commonly called *Domain* members.

It should be noted that *Workgroup* membership involve no special configuration other than the machine being configured so that the network configuration has a commonly used name for it's workgroup entry. It is not uncommon for the name WORKGROUP to be used for this. With this mode of configuration there are NO machine trust accounts and any concept of membership as such is limited to the fact that all machines appear in the network neighbourhood to be logically grouped together. Again, just to be clear: *workgroup mode does not involve any security machine accounts.*

Domain member machines have a machine account in the Domain accounts database. A special procedure must be followed on each machine to affect Domain membership. This procedure, which can be done only by the local machine Administrator account, will create the Domain machine account (if it does not exist), and then initializes that account. When the client first logs onto the Domain it triggers a machine password change.

NOTE

When running a Domain all MS Windows NT / 200x / XP Professional clients should be configured as full Domain Members - IF A SECURE NETWORK IS WANTED. If the machine is NOT made a member of the Domain, then it will operate like a workgroup (stand-alone) machine. Please refer the **Domain Membership** chapter for information regarding HOW to make your MS Windows clients Domain members.

The following are necessary for configuring Samba-3 as an MS Windows NT4 style PDC for MS Windows NT4 / 200x / XP clients.

- Configuration of basic TCP/IP and MS Windows Networking
- Correct designation of the Server Role (security = user)
- Consistent configuration of Name Resolution (See chapter on **Browsing** and on **MS Windows network Integration**)
- Domain logons for Windows NT4 / 200x / XP Professional clients
- Configuration of Roaming Profiles or explicit configuration to force local profile usage
- Configuration of Network/System Policies
- Adding and managing domain user accounts
- Configuring MS Windows client machines to become domain members

The following provisions are required to serve MS Windows 9x / Me Clients:

- Configuration of basic TCP/IP and MS Windows Networking
- Correct designation of the Server Role (security = user)
- Network Logon Configuration (Since Windows 9x / XP Home are not technically domain members, they do not really participate in the security aspects of Domain logons as such)
- Roaming Profile Configuration
- Configuration of System Policy handling
- Installation of the Network driver "Client for MS Windows Networks" and configuration to log onto the domain
- Placing Windows 9x / Me clients in user level security - if it is desired to allow all client share access to be controlled according to domain user / group identities.

Adding and managing domain user accounts

NOTE



Roaming Profiles and System/Network policies are advanced network administration topics that are covered in the **Profile Management** and **Policy Management** chapters of this document. However, these are not necessarily specific to a Samba PDC as much as they are related to Windows NT networking concepts.

A Domain Controller is an SMB/CIFS server that:

- Registers and advertises itself as a Domain Controller (through NetBIOS broadcasts as well as by way of name registrations either by Mailslot Broadcasts over UDP broadcast, to a WINS server over UDP unicast, or via DNS and Active Directory)
- Provides the NETLOGON service (actually a collection of services that runs over a number of protocols. These include the LanMan Logon service, the Netlogon service, the Local Security Account service, and variations of them)
- Provides a share called NETLOGON

For Samba to provide these is rather easy to configure. Each Samba Domain Controller must provide the NETLOGON service which Samba calls the *domain logons* functionality (after the name of the parameter in the `smb.conf` file). Additionally, one (1) server in a Samba-3 Domain must advertise itself as the domain master browser. This causes the Primary Domain Controller to claim domain specific NetBIOS name that identifies it as a domain master browser for its given domain/workgroup. Local master browsers in the same domain/workgroup on broadcast-isolated subnets then ask for a complete copy of the browse list for the whole wide area network. Browser clients will then contact their local master browser, and will receive the domain-wide browse list, instead of just the list for their broadcast-isolated subnet.

5.3. Domain Control - Example Configuration

The first step in creating a working Samba PDC is to understand the parameters necessary in `smb.conf`. Here we attempt to explain the parameters that are covered in the `smb.conf` man page.

Here is an example `smb.conf` for acting as a PDC:

```
[global]
    ; Basic server settings
    netbios name = POGO
    workgroup = NARNIA

    ; User and Machine Account Backends
    ; Choices are: tdbsam, smbpasswd, ldapsam, mysqlsam, xmlsam, guest
    passdb backend = ldapsam, guest

    ; we should act as the domain and local master browser
    os level = 64
    preferred master = yes
```

```
domain master = yes
local master = yes

; security settings (must user security = user)
security = user

; encrypted passwords are a requirement for a PDC (default = Yes)
encrypt passwords = yes

; support domain logons
domain logons = yes

; where to store user profiles?
logon path = \\%N\profiles\%u

; where is a user's home directory and where should it be mounted at?
logon drive = H:
logon home = \\homeserver\%u\winprofile

; specify a generic logon script for all users
; this is a relative **DOS** path to the [netlogon] share
logon script = logon.cmd

; necessary share for domain controller
[netlogon]
  path = /usr/local/samba/lib/netlogon
  read only = yes
  write list = ntadmin

; share for storing user profiles
[profiles]
  path = /export/smb/ntprofile
  read only = no
  create mask = 0600
  directory mask = 0700
```

NOTE

The above parameters make for a full set of parameters that may define the server's mode of operation. The following parameters are the essentials alone:



```
workgroup = NARNIA
domain logons = Yes
domain master = Yes
security = User
```

The additional parameters shown in the longer listing above just makes for a more complete environment.

There are a couple of points to emphasize in the above configuration.

- Encrypted passwords must be enabled. For more details on how to do this, refer to [Account Information Database chapter](#).
- The server must support domain logons and have a [netlogon] share
- The server must be the domain master browser in order for Windows client to locate the server as a DC. Please refer to the various Network Browsing documentation included with this distribution for details.

5.4. Samba ADS Domain Control

Samba-3 is not and can not act as an Active Directory Server. It can not truly function as an Active Directory Primary Domain Controller. The protocols for some of the functionality the Active Directory Domain Controllers is have been partially implemented on an experimental only basis. Please do NOT expect Samba-3 to support these protocols - nor should you depend on any such functionality either now or in the future. The Samba-Team may well remove such experiemental features or may change their behaviour.

5.5. Domain and Network Logon Configuration

The subject of Network or Domain Logons is discussed here because it rightly forms an integral part of the essential functionality that is provided by a Domain Controller.

5.5.1. Domain Network Logon Service

All Domain Controllers must run the netlogon service (*domain logons* in Samba). One Domain Controller must be configured with domain master = Yes (the Primary Domain Controller); on ALL Backup Domain Controllers domain master = No must be set.

5.5.1.1. Example Configuration

```
[globals]
domain logons = Yes
domain master = (Yes on PDC, No on BDCs)
```



```
[netlogon]
  comment = Network Logon Service
  path = /var/lib/samba/netlogon
  guest ok = Yes
  browseable = No
```

5.5.1.2. The Special Case of MS Windows XP Home Edition

NOTE



MS Windows XP Home Edition does not have the ability to join any type of Domain security facility. Unlike, MS Windows 9x / Me, MS Windows XP Home Edition also completely lacks the ability to log onto a network.

To be completely clear: If you want MS Windows XP Home Edition to integrate with your MS Windows NT4 or Active Directory Domain security understand - IT CAN NOT BE DONE. Your only choice is to buy the upgrade pack from MS Windows XP Home Edition to MS Windows XP Professional.

Now that this has been said, please do NOT ask the mailing list, or email any of the Samba-Team members with your questions asking how to make this work. It can't be done.

5.5.1.3. The Special Case of Windows 9x / Me

A domain and a workgroup are exactly the same thing in terms of network browsing. The difference is that a distributable authentication database is associated with a domain, for secure login access to a network. Also, different access rights can be granted to users if they successfully authenticate against a domain logon server. Samba-3 does this now in the same way that MS Windows NT/2K.

The SMB client logging on to a domain has an expectation that every other server in the domain should accept the same authentication information. Network browsing functionality of domains and workgroups is identical and is explained in this documentation under the browsing discussions. It should be noted, that browsing is totally orthogonal to logon support.

Issues related to the single-logon network model are discussed in this section. Samba supports domain logons, network logon scripts, and user profiles for MS Windows for workgroups and MS Windows 9X/ME clients which are the focus of this section.

When an SMB client in a domain wishes to logon, it broadcasts requests for a logon server. The first one to reply gets the job, and validates its password using whatever mechanism the Samba administrator has installed. It is possible (but very stupid) to create a domain where the user database is not shared between servers, i.e. they are effectively workgroup servers advertising themselves as participating in a domain. This demonstrates how authentication is quite different from but closely involved with domains.

Using these features you can make your clients verify their logon via the Samba server; make clients run a batch file when they logon to the network and download

their preferences, desktop and start menu.

MS Windows XP Home edition is NOT able to join a domain and does not permit the use of domain logons.

Before launching into the configuration instructions, it is worthwhile to look at how a Windows 9x/ME client performs a logon:

1. The client broadcasts (to the IP broadcast address of the subnet it is in) a NetLogon request. This is sent to the NetBIOS name DOMAIN<#1c> at the NetBIOS layer. The client chooses the first response it receives, which contains the NetBIOS name of the logon server to use in the format of \\SERVER.
2. The client then connects to that server, logs on (does an SMBssetupX) and then connects to the IPC\$ share (using an SMBtconX).
3. The client then does a NetWkstaUserLogon request, which retrieves the name of the user's logon script.
4. The client then connects to the NetLogon share and searches for said script and if it is found and can be read, is retrieved and executed by the client. After this, the client disconnects from the NetLogon share.
5. The client then sends a NetUserGetInfo request to the server, to retrieve the user's home share, which is used to search for profiles. Since the response to the NetUserGetInfo request does not contain much more than the user's home share, profiles for Win9X clients MUST reside in the user home directory.
6. The client then connects to the user's home share and searches for the user's profile. As it turns out, you can specify the user's home share as a share-name and path. For example, \\server\fred\.winprofile. If the profiles are found, they are implemented.
7. The client then disconnects from the user's home share, and reconnects to the NetLogon share and looks for CONFIG.POL, the policies file. If this is found, it is read and implemented.

The main difference between a PDC and a Windows 9x logon server configuration is that

- Password encryption is not required for a Windows 9x logon server. But note that beginning with MS Windows 98 the default setting is that plain-text password support has been disabled. It can be re-enabled with the registry changes that are documented in the chapter on Policies.
- Windows 9x/ME clients do not require and do not use machine trust accounts.

A Samba PDC will act as a Windows 9x logon server; after all, it does provide the network logon services that MS Windows 9x / Me expect to find.

5.5.2. Security Mode and Master Browsers

There are a few comments to make in order to tie up some loose ends. There has been much debate over the issue of whether or not it is ok to configure Samba as a Domain Controller in security modes other than USER. The only security mode which will not work due to technical reasons is SHARE mode security. DOMAIN and SERVER mode security are really just a variation on SMB user level security.

Actually, this issue is also closely tied to the debate on whether or not Samba must be the domain master browser for its workgroup when operating as a DC. While it may technically be possible to configure a server as such (after all, browsing and domain logons are two distinctly different functions), it is not a good idea to do so. You should remember that the DC must register the DOMAIN<#1b> NetBIOS name. This is the name used by Windows clients to locate the DC. Windows clients do not distinguish between the DC and the DMB. For this reason, it is very wise to configure the Samba DC as the DMB.

Now back to the issue of configuring a Samba DC to use a mode other than security = user. If a Samba host is configured to use another SMB server or DC in order to validate user connection requests, then it is a fact that some other machine on the network (the password server) knows more about the user than the Samba host. 99% of the time, this other host is a domain controller. Now in order to operate in domain mode security, the workgroup parameter must be set to the name of the Windows NT domain (which already has a domain controller). If the domain does NOT already have a Domain Controller then you do not yet have a Domain!

Configuring a Samba box as a DC for a domain that already by definition has a PDC is asking for trouble. Therefore, you should always configure the Samba DC to be the DMB for its domain and set security = user. This is the only officially supported mode of operation.

5.6. Common Problems and Errors

5.6.1. I cannot include a '\$' in a machine name

A 'machine account', (typically) stored in `/etc/passwd`, takes the form of the machine name with a '\$' appended. FreeBSD (and other BSD systems?) won't create a user with a '\$' in their name.

The problem is only in the program used to make the entry. Once made, it works perfectly. Create a user without the '\$'. Then use `vipw` to edit the entry, adding the '\$'. Or create the whole entry with `vipw` if you like; make sure you use a unique User ID!

5.6.2. I get told "You already have a connection to the Domain..." or "Cannot join domain, the credentials supplied conflict with an existing set.." when creating a machine trust account.

This happens if you try to create a machine trust account from the machine itself and already have a connection (e.g. mapped drive) to a share (or IPC\$) on the Samba PDC. The following command will remove all network drive connections:

```
C:\WINNT> net use * /d
```

Further, if the machine is already a 'member of a workgroup' that is the same name as the domain you are joining (bad idea) you will get this message. Change the workgroup name to something else, it does not matter what, reboot, and try again.

5.6.3. The system can not log you on (C000019B)....

I joined the domain successfully but after upgrading to a newer version of the Samba code I get the message, The system can not log you on (C000019B), Please try again or consult your system administrator when attempting to logon.

This occurs when the domain SID stored in the `secrets.tdb` database is changed. The most common cause of a change in domain SID is when the domain name and/or the server name (NetBIOS name) is changed. The only way to correct the problem is to restore the original domain SID or remove the domain client from the domain and rejoin. The domain SID may be reset using either the `net` or `rpcclient` utilities.

The reset or change the domain SID you can use the `net` command as follows:

```
root# net getlocalsid 'OLDNAME'
```

```
root# net setlocalsid 'SID'
```

5.6.4. The machine trust account for this computer either does not exist or is not accessible.

When I try to join the domain I get the message The machine account for this computer either does not exist or is not accessible. What's wrong?

This problem is caused by the PDC not having a suitable machine trust account. If you are using the add machine script method to create accounts then this would indicate that it has not worked. Ensure the domain admin user system is working.

Alternatively if you are creating account entries manually then they have not been created correctly. Make sure that you have the entry correct for the machine trust account in smbpasswd file on the Samba PDC. If you added the account using an editor rather than using the smbpasswd utility, make sure that the account name is the machine NetBIOS name with a '\$' appended to it (i.e. computer_name\$). There must be an entry in both /etc/passwd and the smbpasswd file.

Some people have also reported that inconsistent subnet masks between the Samba server and the NT client can cause this problem. Make sure that these are consistent for both client and server.

5.6.5. When I attempt to login to a Samba Domain from a NT4/W2K workstation, I get a message about my account being disabled.

Enable the user accounts with smbpasswd -e username, this is normally done as an account is created.

5.6.6. Until a few minutes after Samba has started, clients get the error "Domain Controller Unavailable"

A domain controller has to announce on the network who it is. This usually takes a while.

6. Backup Domain Control

Before you continue reading in this section, please make sure that you are comfortable with configuring a Samba Domain Controller as described in the [Domain Control Chapter](#).

6.1. Features And Benefits

This is one of the most difficult chapters to summarise. It matters not what we say here for someone will still draw conclusions and / or approach the Samba-Team with expectations that are either not yet capable of being delivered, or that can be achieved for more effectively using a totally different approach. Since this HOWTO is already so large and extensive, we have taken the decision to provide sufficient (but not comprehensive) information regarding Backup Domain Control. In the event that you should have a persistent concern that is not addressed in this HOWTO document then please email [John H Terpstra](#) clearly setting out your requirements and / or question and we will do our best to provide a solution.

Samba-3 is capable of acting as a Backup Domain Controller to another Samba Primary Domain Controller. A Samba-3 PDC can operate with an LDAP Account backend. The Samba-3 BDC can operate with a slave LDAP server for the Account backend. This effectively gives samba a high degree of scalability. This is a very sweet (nice) solution for large organisations.

While it is possible to run a Samba-3 BDC with non-LDAP backend, the administrator will need to figure out precisely what is the best way to replicate (copy / distribute) the user and machine Accounts backend.

The use of a non-LDAP backend SAM database is particularly problematic because Domain member servers and workstations periodically change the machine trust account password. The new password is then stored only locally. This means that in the absence of a centrally stored accounts database (such as that provided with an LDAP based solution) if Samba-3 is running as a BDC, the PDC instance of the Domain member trust account password will not reach the PDC (master) copy of the SAM. If the PDC SAM is then replicated to BDCs this results in overwriting of the SAM that contains the updated (changed) trust account password with resulting breakage of the domain trust.

Considering the number of comments and questions raised concerning how to configure a BDC lets consider each possible option and look at the pro's and con's for each theoretical solution:

BACKUP DOMAIN BACKEND ACCOUNT DISTRIBUTION OPTIONS

- Solution: Passwd Backend is LDAP based, BDCs use a slave LDAP server
Arguments For: This is a neat and manageable solution. The LDAP based SAM (ldapsam) is constantly kept up to date.
Arguments Against: Complexity
- Passdb Backend is tdbsam based, BDCs use cron based "net rcp vampire" to suck down the Accounts database from the PDC
Arguments For: It would be a nice solution
Arguments Against: It does not work because Samba-3 does not support the required protocols. This may become a later feature but is not available today.

- Make use of rsync to replicate (pull down) copies of the essential account files
Arguments For: It is a simple solution, easy to set up as a scheduled job
Arguments Against: This will over-write the locally changed machine trust account passwords. This is a broken and flawed solution. Do NOT do this.
- Operate with an entirely local accounts database (not recommended)
Arguments For: Simple, easy to maintain
Arguments Against: All machine trust accounts and user accounts will be locally maintained. Domain users will NOT be able to roam from office to office. This is a broken and flawed solution. Do NOT do this.

6.2. Essential Background Information

A Domain Controller is a machine that is able to answer logon requests from network workstations. Microsoft LanManager and IBM LanServer were two early products that provided this capability. The technology has become known as the LanMan Netlogon service.

When MS Windows NT3.10 was first released it supported a new style of Domain Control and with it a new form of the network logon service that has extended functionality. This service became known as the NT NetLogon Service. The nature of this service has changed with the evolution of MS Windows NT and today provides a very complex array of services that are implemented over a complex spectrum of technologies.

6.2.1. MS Windows NT4 Style Domain Control

Whenever a user logs into a Windows NT4 / 200x / XP Professional Workstation, the workstation connects to a Domain Controller (authentication server) to validate the username and password that the user entered are valid. If the information entered does not validate against the account information that has been stored in the Domain Control database (the SAM, or Security Accounts Manager database) then a set of error codes is returned to the workstation that has made the authentication request.

When the username / password pair has been validated, the Domain Controller (authentication server) will respond with full enumeration of the account information that has been stored regarding that user in the User and Machine Accounts database for that Domain. This information contains a complete network access profile for the user but excludes any information that is particular to the user's desktop profile, or for that matter it excludes all desktop profiles for groups that the user may belong to. It does include password time limits, password uniqueness controls, network access time limits, account validity information, machine names from which the user may access the network, and much more. All this information was stored in the SAM in all versions of MS Windows NT (3.10, 3.50, 3.51, 4.0).

The account information (user and machine) on Domain Controllers is stored in two files, one containing the Security information and the other the SAM. These are stored in files by the same name in the `C:\WinNT\System32\config` directory. These are the files that are involved in replication of the SAM database where Backup Domain Controllers are present on the network.

There are two situations in which it is desirable to install Backup Domain Controllers:

- On the local network that the Primary Domain Controller is on if there are many workstations and/or where the PDC is generally very busy. In this case the BDCs will pick up network logon requests and help to add robustness to network services.

- At each remote site, to reduce wide area network traffic and to add stability to remote network operations. The design of the network, the strategic placement of Backup Domain Controllers, together with an implementation that localises as much of network to client interchange as possible will help to minimise wide area network bandwidth needs (and thus costs).

The PDC contains the master copy of the SAM. In the event that an administrator makes a change to the user account database while physically present on the local network that has the PDC, the change will likely be made directly to the PDC instance of the master copy of the SAM. In the event that this update may be performed in a branch office the change will likely be stored in a delta file on the local BDC. The BDC will then send a trigger to the PDC to commence the process of SAM synchronisation. The PDC will then request the delta from the BDC and apply it to the master SAM. The PDC will then contact all the BDCs in the Domain and trigger them to obtain the update and then apply that to their own copy of the SAM.

Thus the BDC is said to hold a *read-only* of the SAM from which it is able to process network logon requests and to authenticate users. The BDC can continue to provide this service, particularly while, for example, the wide area network link to the PDC is down. Thus a BDC plays a very important role in both maintenance of Domain security as well as in network integrity.

In the event that the PDC should need to be taken out of service, or if it dies, then one of the BDCs can be promoted to a PDC. If this happens while the original PDC is on line then it is automatically demoted to a BDC. This is an important aspect of Domain Controller management. The tool that is used to affect a promotion or a demotion is the Server Manager for Domains.

6.2.1.1. Example PDC Configuration

Since version 2.2 Samba officially supports domain logons for all current Windows Clients, including Windows NT4, 2003 and XP Professional. For samba to be enabled as a PDC some parameters in the [global]-section of the `smb.conf` have to be set:

```
workgroup = SAMBA
domain master = yes
domain logons = yes
```

Several other things like a [homes] and a [netlogon] share also need to be set along with settings for the profile path, the users home drive, etc.. This will not be covered in this chapter, for more information please refer to the chapter on Domain Control.

6.2.2. Active Directory Domain Control

As of the release of MS Windows 2000 and Active Directory, this information is now stored in a directory that can be replicated and for which partial or full administrative control can be delegated. Samba-3 is NOT able to be a Domain Controller within an Active Directory tree, and it can not be an Active Directory server. This means that Samba-3 also can NOT act as a Backup Domain Controller to an Active Directory Domain Controller.

6.2.3. What qualifies a Domain Controller on the network?

Every machine that is a Domain Controller for the domain SAMBA has to register the NetBIOS group name SAMBA<#1c> with the WINS server and/or by

broadcast on the local network. The PDC also registers the unique NetBIOS name SAMBA<#1b> with the WINS server. The name type <#1b> name is normally reserved for the Domain Master Browser, a role that has nothing to do with anything related to authentication, but the Microsoft Domain implementation requires the domain master browser to be on the same machine as the PDC.

6.2.4. How does a Workstation find its domain controller?

An MS Windows NT4 / 200x / XP Professional workstation in the domain SAMBA that wants a local user to be authenticated has to find the domain controller for SAMBA. It does this by doing a NetBIOS name query for the group name SAMBA<#1c>. It assumes that each of the machines it gets back from the queries is a domain controller and can answer logon requests. To not open security holes both the workstation and the selected domain controller authenticate each other. After that the workstation sends the user's credentials (name and password) to the local Domain Controller, for validation.

6.3. Backup Domain Controller Configuration

Several things have to be done:

- The domain SID has to be the same on the PDC and the BDC. This used to be stored in the file `private/MACHINE.SID`. This file is not created anymore since Samba 2.2.5 or even earlier. Nowadays the domain SID is stored in the file `private/secrets.tdb`. Simply copying the `secrets.tdb` from the PDC to the BDC does not work, as the BDC would generate a new SID for itself and override the domain SID with this new BDC SID.
To retrieve the domain SID from the PDC or an existing BDC and store it in the `secrets.tdb`, execute `'net rpc getsid'` on the BDC.
- The Unix user database has to be synchronized from the PDC to the BDC. This means that both the `/etc/passwd` and `/etc/group` have to be replicated from the PDC to the BDC. This can be done manually whenever changes are made, or the PDC is set up as a NIS master server and the BDC as a NIS slave server. To set up the BDC as a mere NIS client would not be enough, as the BDC would not be able to access its user database in case of a PDC failure.
- The Samba password database in the file `private/smbpasswd` has to be replicated from the PDC to the BDC. This is a bit tricky, see the next section.
- Any netlogon share has to be replicated from the PDC to the BDC. This can be done manually whenever login scripts are changed, or it can be done automatically together with the `smbpasswd` synchronization.

6.3.1. Example Configuration

Finally, the BDC has to be found by the workstations. This can be done by setting:

```
workgroup = SAMBA
domain master = no
domain logons = yes
```

in the [global]-section of the `smb.conf` of the BDC. This makes the BDC only register the name SAMBA<#1c> with the WINS server. This is no problem as the name SAMBA<#1c> is a NetBIOS group name that is meant to be registered by more than one machine. The parameter `'domain master = no'` forces the BDC

not to register SAMBA<#1b> which as a unique NetBIOS name is reserved for the Primary Domain Controller.

6.4. Common Errors

As this is a rather new area for Samba there are not many examples that we may refer to. Keep watching for updates to this section.

6.4.1. Machine Accounts keep expiring, what can I do?

This problem will occur when occur when the passdb (SAM) files are copied from a central server but the local Backup Domain Controllers. Local machine trust account password updates are not copied back to the central server. The newer machine account password is then over written when the SAM is copied from the PDC. The result is that the Domain member machine on start up will find that it's passwords does not match the one now in the database and since the startup security check will now fail, this machine will not allow logon attempts to procede and the account expiry error will be reported.

6.4.2. Can Samba be a Backup Domain Controller to an NT4 PDC?

With version 2.2, no. The native NT4 SAM replication protocols have not yet been fully implemented. The Samba Team is working on understanding and implementing the protocols, but this work has not been finished for version 2.2.

With version 3.0, the work on both the replication protocols and a suitable storage mechanism has progressed, and some form of NT4 BDC support is expected soon.

Can I get the benefits of a BDC with Samba? Yes. The main reason for implementing a BDC is availability. If the PDC is a Samba machine, a second Samba machine can be set up to service logon requests whenever the PDC is down.

6.4.3. How do I replicate the smbpasswd file?

Replication of the smbpasswd file is sensitive. It has to be done whenever changes to the SAM are made. Every user's password change is done in the smbpasswd file and has to be replicated to the BDC. So replicating the smbpasswd file very often is necessary.

As the smbpasswd file contains plain text password equivalents, it must not be sent unencrypted over the wire. The best way to set up smbpasswd replication from the PDC to the BDC is to use the utility rsync. rsync can use ssh as a transport. Ssh itself can be set up to accept **only** rsync transfer without requiring the user to type a password.

6.4.4. Can I do this all with LDAP?

The simple answer is YES. Samba's `pdb_ldap` code supports binding to a replica LDAP server, and will also follow referrals and rebind to the master if it ever needs to make a modification to the database. (Normally BDCs are read only, so this will not occur often).

7. Domain Membership

Domain Membership is a subject of vital concern, Samba must be able to participate as a member server in a Microsoft Domain security context, and Samba must be capable of providing Domain machine member trust accounts, otherwise it would not be capable of offering a viable option for many users.

This chapter covers background information pertaining to domain membership, Samba configuration for it, and MS Windows client procedures for joining a domain. Why is this necessary? Because both are areas in which there exists within the current MS Windows networking world and particularly in the Unix/Linux networking and administration world, a considerable level of mis-information, incorrect understanding, and a lack of knowledge. Hopefully this chapter will fill the voids.

7.1. Features and Benefits

MS Windows workstations and servers that want to participate in domain security need to be made Domain members. Participating in Domain security is often called *Single Sign On* or SSO for short. This chapter describes the process that must be followed to make a workstation (or another server - be it an MS Windows NT4 / 200x server) or a Samba server a member of an MS Windows Domain security context.

Samba-3 can join an MS Windows NT4 style domain as a native member server, an MS Windows Active Directory Domain as a native member server, or a Samba Domain Control network.

Domain membership has many advantages:

- MS Windows workstation users get the benefit of SSO
- Domain user access rights and file ownership / access controls can be set from the single Domain SAM (Security Accounts Management) database (works with Domain member servers as well as with MS Windows workstations that are domain members)
- Only MS Windows NT4 / 200x / XP Professional workstations that are Domain members can use network logon facilities
- Domain Member workstations can be better controlled through the use of Policy files (`NTConfig.POL`) and Desktop Profiles.
- Through the use of logon scripts users can be given transparent access to network applications that run off application servers
- Network administrators gain better application and user access management abilities because there is no need to maintain user accounts on any network client or server, other than the central Domain database (either NT4/Samba SAM style Domain, NT4 Domain that is back ended with an LDAP directory, or via an Active Directory infrastructure)

7.2. MS Windows Workstation/Server Machine Trust Accounts

A machine trust account is an account that is used to authenticate a client machine (rather than a user) to the Domain Controller server. In Windows terminology, this is known as a "Computer Account."

The password of a machine trust account acts as the shared secret for secure communication with the Domain Controller. This is a security feature to prevent an unauthorized machine with the same NetBIOS name from joining the domain and gaining access to domain user/group accounts. Windows NT, 200x, XP Professional clients use machine trust accounts, but Windows 9x / Me / XP Home clients do not. Hence, a Windows 9x / Me / XP Home client is never a true member of a domain because it does not possess a machine trust account, and thus has no shared secret with the domain controller.

A Windows NT4 PDC stores each machine trust account in the Windows Registry. The introduction of MS Windows 2000 saw the introduction of Active Directory, the new repository for machine trust accounts.

A Samba PDC, however, stores each machine trust account in two parts, as follows:

- A Domain Security Account (stored in the `passwd` backend that has been configured in the `smb.conf` file. The precise nature of the account information that is stored depends on the type of backend database that has been chosen. The older format of this data is the `smbpasswd` database which contains the unix login ID, the Unix user identifier (UID), and the LanMan and NT encrypted passwords. There is also some other information in this file that we do not need to concern ourselves with here.

The two newer database types are called `ldapsam`, `tdbsam`. Both store considerably more data than the older `smbpasswd` file did. The extra information enables new user account controls to be used.

- A corresponding Unix account, typically stored in `/etc/passwd`. Work is in progress to allow a simplified mode of operation that does not require Unix user accounts, but this may not be a feature of the early releases of Samba-3.

There are three ways to create machine trust accounts:

- Manual creation from the Unix/Linux command line. Here, both the Samba and corresponding Unix account are created by hand.
- Using the MS Windows NT4 Server Manager (either from an NT4 Domain member server, or using the Nexus toolkit available from the Microsoft web site. This tool can be run from any MS Windows machine so long as the user is logged on as the administrator account.
- "On-the-fly" creation. The Samba machine trust account is automatically created by Samba at the time the client is joined to the domain. (For security, this is the recommended method.) The corresponding Unix account may be created automatically or manually.

7.2.1. Manual Creation of Machine Trust Accounts

The first step in manually creating a machine trust account is to manually create the corresponding Unix account in `/etc/passwd`. This can be done using `vipw` or another 'add user' command that is normally used to create new Unix accounts. The following is an example for a Linux based Samba server:

```
root#/usr/sbin/useradd -g 100 -d /dev/null -c "machine nickname" -s /bin/false
machine_name$
root#passwd -l machine_name$
```

On *BSD systems, this can be done using the `chpass` utility:

```
root#chpass -a "machine_name$:*:101:100::0:0:Workstation machine_name:/dev/null:/sbin/nologin"
```

The `/etc/passwd` entry will list the machine name with a "\$" appended, won't have a password, will have a null shell and no home directory. For example a machine named 'doppy' would have an `/etc/passwd` entry like this:

```
doppy$:x:505:501:machine_nickname:/dev/null:/bin/false
```

Above, `machine_nickname` can be any descriptive name for the client, i.e., `BasementComputer`. `machine_name` absolutely must be the NetBIOS name of the client to be joined to the domain. The "\$" must be appended to the NetBIOS name of the client or Samba will not recognize this as a machine trust account.

Now that the corresponding Unix account has been created, the next step is to create the Samba account for the client containing the well-known initial machine trust account password. This can be done using the `smbpasswd(8)` command as shown here:

```
root# smbpasswd -a -m machine_name
```

>

where `machine_name` is the machine's NetBIOS name. The RID of the new machine account is generated from the UID of the corresponding Unix account.

JOIN THE CLIENT TO THE DOMAIN IMMEDIATELY



Manually creating a machine trust account using this method is the equivalent of creating a machine trust account on a Windows NT PDC using the Server Manager. From the time at which the account is created to the time which the client joins the domain and changes the password, your domain is vulnerable to an intruder joining your domain using a machine with the same NetBIOS name. A PDC inherently trusts members of the domain and will serve out a large degree of user information to such clients. You have been warned!

7.2.2. Using NT4 Server Manager to Add Machine Accounts to the Domain

If the machine from which you are trying to manage the domain is an MS Windows NT4 workstation then the tool of choice is the package called `SRVTOOLS.EXE`. When executed in the target directory this will unpack `SrvMge.exe` and `UsrMgr.exe` (both are Domain Management tools for MS Windows NT4 workstation).

If your workstation is any other MS Windows product you should download the `Nexus.exe` package from the Microsoft web site. When executed from the target directory this will unpack the same tools but for use on MS Windows 9x/Me/200x/XP.

Launch the `srvmgr.exe` (Server Manager for Domains) and follow these steps:

SERVER MANAGER ACCOUNT MACHINE ACCOUNT MANAGEMENT

1. From the menu select **Computer**
2. Click on **Select Domain**
3. Click on the name of the domain you wish to administer in the **Select Domain** panel and then click **OK**.
4. Again from the menu select **Computer**
5. Select **Add to Domain**
6. In the dialog box, click on the radio button to **Add NT Workstation of Server**, then enter the machine name in the field provided, then click the **Add** button.

7.2.3. "On-the-Fly" Creation of Machine Trust Accounts

The second (and recommended) way of creating machine trust accounts is simply to allow the Samba server to create them as needed when the client is joined to the domain.

Since each Samba machine trust account requires a corresponding Unix account, a method for automatically creating the Unix account is usually supplied; this requires configuration of the [add machine script](#) option in `smb.conf`. This method is not required, however; corresponding Unix accounts may also be created manually.

Below is an example for a RedHat Linux system.

```
[global]
# <...remainder of parameters...>
add machine script = /usr/sbin/useradd -d /dev/null -g 100 -s /bin/false -M %u
```

7.2.4. Making an MS Windows Workstation or Server a Domain Member

The procedure for making an MS Windows workstation or server a member of the domain varies with the version of Windows:

7.2.4.1. Windows 200x XP Professional

When the user elects to make the client a domain member, Windows 200x prompts for an account and password that has privileges to create machine accounts in the domain. A Samba administrative account (i.e., a Samba account that has root privileges on the Samba server) must be entered here; the operation will fail if an ordinary user account is given.

Note: For security reasons the password for this administrative account should be set to a password that is other than that used for the root user in the `/etc/passwd`.

The name of the account that is used to create domain member machine accounts can be anything the network administrator may choose. If it is other than `root` then this is easily mapped to root using the file pointed to be the `smb.conf` parameter `username map = /etc/samba/smbusers`.

The session key of the Samba administrative account acts as an encryption key for setting the password of the machine trust account. The machine trust account will be created on-the-fly, or updated if it already exists.

7.2.4.2. Windows NT4

If the machine trust account was created manually, on the Identification Changes menu enter the domain name, but do not check the box **Create a Computer Account in the Domain**. In this case, the existing machine trust account is used to join the machine to the domain.

If the machine trust account is to be created on-the-fly, on the Identification Changes menu enter the domain name, and check the box **Create a Computer Account in the Domain**. In this case, joining the domain proceeds as above for Windows 2000 (i.e., you must supply a Samba administrative account when prompted).

7.2.4.3. Samba

Joining a samba client to a domain is documented in the [Domain Member](#) chapter.

7.3. Domain Member Server

This mode of server operation involves the samba machine being made a member of a domain security context. This means by definition that all user authentication will be done from a centrally defined authentication regime. The authentication regime may come from an NT3/4 style (old domain technology) server, or it may be provided from an Active Directory server (ADS) running on MS Windows 2000 or later.

Of course it should be clear that the authentication back end itself could be from any distributed directory architecture server that is supported by Samba. This can be LDAP (from OpenLDAP), or Sun's iPlanet, or NetWare Directory Server, etc.

Please refer to the [Domain Control chapter](#) for more information regarding how to create a domain machine account for a domain member server as well as for information regarding how to enable the samba domain member machine to join the domain and to be fully trusted by it.

7.3.1. Joining an NT4 type Domain with Samba-3

Table 7.1: Assumptions

NetBIOS name:	SERV1
Win2K/NT domain name:	DOM
Domain's PDC NetBIOS name:	DOMPDC
Domain's BDC NetBIOS names:	DOMBDC1 and DOMBDC2

First, you must edit your `smb.conf` file to tell Samba it should now use domain security.

Change (or add) your `security` line in the `[global]` section of your `smb.conf` to read:

```
security = domain
```

Next change the `workgroup` line in the `[global]` section to read:

```
workgroup = DOM
```

as this is the name of the domain we are joining.

You must also have the parameter `encrypt passwords` set to `yes` in order for your users to authenticate to the NT PDC.

Finally, add (or modify) a `password server` line in the `[global]` section to read:

```
password server = DOMPDC DOMBDC1 DOMBDC2
```

These are the primary and backup domain controllers Samba will attempt to contact in order to authenticate users. Samba will try to contact each of these servers in order, so you may want to rearrange this list in order to spread out the authentication load among domain controllers.

Alternatively, if you want `smbd` to automatically determine the list of Domain controllers to use for authentication, you may set this line to be:

```
password server = *
```

This method, allows Samba to use exactly the same mechanism that NT does. This method either broadcasts or uses a WINS database in order to find domain controllers to authenticate against.

In order to actually join the domain, you must run this command:

```
root# net join -S DOMPDC -UAdministrator%password
```

If the `-S DOMPDC` argument is not given then the domain name will be obtained from `smb.conf`.

As we are joining the domain DOM and the PDC for that domain (the only machine that has write access to the domain SAM database) is DOMPDC. The `Administrator%password` is the login name and password for an account which has the necessary privilege to add machines to the domain. If this is successful you will see the message:

```
Joined domain DOM. or Joined 'SERV1' to realm 'MYREALM'
```

in your terminal window. See the [net\(8\)](#) man page for more details.

This process joins the server to the domain without having to create the machine trust account on the PDC beforehand.

This command goes through the machine account password change protocol, then writes the new (random) machine account password for this Samba server into a file in the same directory in which an `smbpasswd` file would be stored - normally :

```
/usr/local/samba/private/secrets.tdb
```

This file is created and owned by root and is not readable by any other user. It is the key to the domain-level security for your system, and should be treated as carefully as a shadow password file.

Finally, restart your Samba daemons and get ready for clients to begin using domain security!

7.3.2. Why is this better than `security = server`?

Currently, domain security in Samba doesn't free you from having to create local Unix users to represent the users attaching to your server. This means that if domain user `DOM\fred` attaches to your domain security Samba server, there needs to be a local Unix user `fred` to represent that user in the Unix filesystem. This is very similar to the older Samba security mode `security = server`, where Samba would pass through the authentication request to a Windows NT server in the same way as a Windows 95 or Windows 98 server would.

Please refer to the [Winbind paper](#) for information on a system to automatically assign UNIX uids and gids to Windows NT Domain users and groups.

The advantage to domain-level security is that the authentication in domain-level security is passed down the authenticated RPC channel in exactly the same way that an NT server would do it. This means Samba servers now participate in domain trust relationships in exactly the same way NT servers do (i.e., you can add Samba servers into a resource domain and have the authentication passed on from a resource domain PDC to an account domain PDC).

In addition, with `security = server` every Samba daemon on a server has to keep a connection open to the authenticating server for as long as that daemon lasts. This can drain the connection resources on a Microsoft NT server and cause it to run out of available connections. With `security = domain`, however, the Samba daemons connect to the PDC/BDC only for as long as is necessary to authenticate the user, and then drop the connection, thus conserving PDC connection resources.

And finally, acting in the same manner as an NT server authenticating to a PDC means that as part of the authentication reply, the Samba server gets the user identification information such as the user SID, the list of NT groups the user belongs to, etc.

NOTE

Much of the text of this document was first published in the Web magazine [LinuxWorld](#) as the article [Doing the NIS/NT Samba](#).

7.4. Samba ADS Domain Membership

This is a rough guide to setting up Samba 3.0 with kerberos authentication against a Windows2000 KDC.

7.4.1. Setup your smb.conf

You must use at least the following 3 options in `smb.conf`:

```
realm = your.kerberos.REALM
security = ADS
encrypt passwords = yes
```

In case samba can't figure out your ads server using your realm name, use the `ads server` option in `smb.conf`:

```
ads server = your.kerberos.server
```

NOTE

You do *not* need a `smbpasswd` file, and older clients will be authenticated as if `security = domain`, although it won't do any harm and allows you to have local users not in the domain. It is expected that the above required options will change soon when active directory integration will get better.

7.4.2. Setup your `/etc/krb5.conf`

The minimal configuration for `krb5.conf` is:

```
[realms]
  YOUR.KERBEROS.REALM = {
    kdc = your.kerberos.server
  }
```

Test your config by doing a kinit USERNAME@REALM and making sure that your password is accepted by the Win2000 KDC.

NOTE

The realm must be uppercase or you will get Cannot find KDC for requested realm while getting initial credentials error

NOTE

Time between the two servers must be synchronized. You will get a kinit(v5): Clock skew too great while getting initial credentials if the time difference is more than five minutes.

You also must ensure that you can do a reverse DNS lookup on the IP address of your KDC. Also, the name that this reverse lookup maps to must either be the netbios name of the KDC (ie. the hostname with no domain attached) or it can alternatively be the netbios name followed by the realm.

The easiest way to ensure you get this right is to add a `/etc/hosts` entry mapping the IP address of your KDC to its netbios name. If you don't get this right then you will get a local error when you try to join the realm.

If all you want is kerberos support in smbclient then you can skip straight to [Test with smbclient](#) now. [Creating a computer account](#) and [testing your servers](#) is only needed if you want kerberos support for smb and winbind.

7.4.3. Create the computer account

As a user that has write permission on the Samba private directory (usually root) run:

```
net join -U Administrator%password
```

7.4.3.1. Possible errors

ADS support not compiled in Samba must be reconfigured (remove `config.cache`) and recompiled (make clean all install) after the kerberos libs and headers are installed.

net join prompts for user name You need to login to the domain using kinit USERNAME@REALM. USERNAME must be a user who has rights to add a machine to the domain.

7.4.4. Test your server setup

If the join was successful, you will see a new computer account with the NetBIOS name of your Samba server in Active Directory (in the "Computers" folder under Users and Computers).

On a Windows 2000 client try `net use * \\server\share`. You should be logged in with kerberos without needing to know a password. If this fails then run `klist tickets`.

Did you get a ticket for the server? Does it have an encoding type of DES-CBC-MD5 ?

7.4.5. Testing with smbclient

On your Samba server try to login to a Win2000 server or your Samba server using smbclient and kerberos. Use smbclient as usual, but specify the -k option to choose kerberos authentication.

7.4.6. Notes

You must change administrator password at least once after DC install, to create the right encoding types

W2k doesn't seem to create the `_kerberos._udp` and `_ldap._tcp` in their defaults DNS setup. Maybe fixed in service packs?

7.5. Common Errors

In the process of adding / deleting / re-adding domain member machine accounts there are many traps for the unwary player and there are many "little" things that can go wrong. It is particularly interesting how often subscribers on the samba mailing list have concluded after repeated failed attempts to add a machine account that it is necessary to "re-install" MS Windows on the machine. In truth, it is seldom necessary to reinstall because of this type of problem. The real solution is often very simple, and with understanding of how MS Windows networking functions. easily overcome.

7.5.1. Can Not Add Machine Back to Domain

Problem: A Windows workstation was reinstalled. The original domain machine account was deleted and added immediately. The workstation will not join the domain if I use the same machine name. Attempts to add the machine fail with a message that the machine already exists on the network - I know it doesn't. Why is this failing?

The original name is still in the NetBIOS name cache and must expire after machine account deletion BEFORE adding that same name as a domain member again. The best advice is to delete the old account and then to add the machine with a new name.

7.5.2. Adding Machine to Domain Fails

Adding a Windows 200x or XP Professional machine to the Samba PDC Domain fails with a message that, The machine could not be added at this time, there is a network problem. Please try again later. Why?

You should check that there is an add machine script in your `smb.conf` file. If there is not, please add one that is appropriate for your OS platform. If a script has been defined you will need to debug it's operation. Increase the log level in the `smb.conf` file to level 10, then try to rejoin the domain. Check the logs to see which operation is failing.

Possible causes include:

- The script does not actually exist, or could not be located in the path specified.
Corrective Action: Fix it. Make sure that when run manually that the script will add both the Unix system account `_and_` the Samba SAM account.

- The machine could not be added to the Unix system accounts file `/etc/passwd`
Corrective Action: Check that the machine name is a legal Unix system account name. ie: If the Unix utility **useradd** is called then make sure that the machine name you are trying to add can be added using this tool. **Useradd** on some systems will not allow any upper case characters nor will it allow spaces in the name.

8. Stand-Alone Servers

Stand-Alone servers are independent of Domain Controllers on the network. They are NOT domain members and function more like workgroup servers. In many cases a stand-alone server is configured with a minimum of security control with the intent that all data served will be readily accessible to all users.

8.1. Features and Benefits

Stand-Alone servers can be as secure or as insecure as needs dictate. They can have simple or complex configurations. Above all, despite the hoopla about Domain security they remain a very common installation.

If all that is needed is a server for read-only files, or for printers alone, it may not make sense to affect a complex installation. For example: A drafting office needs to store old drawings and reference standards. No-one can write files to the server as it is legislatively important that all documents remain unaltered. A share mode read-only stand-alone server is an ideal solution.

Another situation that warrants simplicity is an office that has many printers that are queued off a single central server. Everyone needs to be able to print to the printers, there is no need to affect any access controls and no files will be served from the print server. Again a share mode stand-alone server makes a great solution.

8.2. Background

The term *stand-alone server* means that the server will provide local authentication and access control for all resources that are available from it. In general this means that there will be a local user database. In more technical terms, it means that resources on the machine will be made available in either SHARE mode or in USER mode.

No special action is needed other than to create user accounts. Stand-alone servers do NOT provide network logon services. This means that machines that use this server do NOT perform a domain log onto it. Whatever logon facility the workstations are subject to is independent of this machine. It is however necessary to accommodate any network user so that the logon name they use will be translated (mapped) locally on the stand-alone server to a locally known user name. There are several ways this can be done.

Samba tends to blur the distinction a little in respect of what is a stand-alone server. This is because the authentication database may be local or on a remote server, even if from the samba protocol perspective the samba server is NOT a member of a domain security context.

Through the use of PAM (Pluggable Authentication Modules) and nsswitch (the name service switcher) the source of authentication may reside on another server. We would be inclined to call this the authentication server. This means that the samba server may use the local Unix/Linux system password database (`/etc/passwd` or `/etc/shadow`), may use a local `smbpasswd` file, or may use an LDAP back end, or even via PAM and Winbind another CIFS/SMB server for authentication.

8.3. Example Configuration

The following examples are designed to inspire simplicity. It is too easy to attempt a high level of creativity and to introduce too much complexity in server and network design.

8.3.1. Reference Documentation Server

Configuration of a read-only data server that EVERYONE can access is very simple. Here is the smb.conf file that will do this. Assume that all the reference documents are stored in the directory /export, that the documents are owned by a user other than nobody. No home directories are shared, that are no users in the /etc/passwd Unix system database. This is a very simple system to administer.

```
# Global parameters
[global]
    workgroup = MYGROUP
    netbios name = REFDOCS
    security = SHARE
    passdb backend = guest
    wins server = 192.168.1.1

[data]
    comment = Data
    path = /export
    guest only = Yes
```

In the above example the machine name is set to REFDOCS, the workgroup is set to the name of the local workgroup so that the machine will appear in with systems users are familiar with. The only password backend required is the "guest" backend so as to allow default unprivileged account names to be used. Given that there is a WINS server on this network we do use it.

8.3.2. Central Print Serving

Configuration of a simple print server is very simple if you have all the right tools on your system.

ASSUMPTIONS:

1. The print server must require no administration
2. The print spooling and processing system on our print server will be CUPS. (Please refer to the chapter on printing for more information).
3. All printers that the print server will service will be network printers. They will be correctly configured, by the administrator, in the CUPS environment.
4. All workstations will be installed using postscript drivers. The printer of choice is the Apple Color LaserWriter.

In this example our print server will spool all incoming print jobs to /var/spool/samba until the job is ready to be submitted by samba to the CUPS print processor. Since all incoming connections will be as the anonymous (guest) user two things will be required:

ENABLEMENT FOR ANONYMOUS PRINTING

- The Unix/Linux system must have a **guest** account. The default for this is usually the account **nobody**. To find the correct name to use for your version of Samba do the following:

```
$ testparm -s -v | grep "guest account"
```

Then make sure that this account exists in your system password database (/etc/passwd).

- The directory into which Samba will spool the file must have write access for the guest account. The following commands will ensure that this directory is available for use:

```
root# mkdir /var/spool/samba
root# chown nobody.nobody /var/spool/samba
root# chmod a+rwt /var/spool/samba
```

```
# Global parameters
[global]
    workgroup = MYGROUP
    netbios name = PTRSVR1
    security = SHARE
    passdb backend = guest
    wins server = 192.168.1.1
```

```
[printers]
    comment = All Printers
    path = /var/spool/samba
    printer admin = root
    guest ok = Yes
    printable = Yes
    printing = cups
    use client driver = Yes
    browseable = No
```

8.4. Common Errors

The greatest mistake so often made is to make a network configuration too complex. It pays to use the simplest solution that will meet the needs of the moment.

9. MS Windows Network Configuration Guide

9.1. Note

This chapter did not make it into this release. It is planned for the published release of this document.

Part III.

Advanced Configuration

10. Samba / MS Windows Network Browsing Guide

This document contains detailed information as well as a fast track guide to implementing browsing across subnets and / or across workgroups (or domains). WINS is the best tool for resolution of NetBIOS names to IP addresses. WINS is NOT involved in browse list handling except by way of name to address resolution.

NOTE



MS Windows 2000 and later can be configured to operate with NO NetBIOS over TCP/IP. Samba-3 and later also supports this mode of operation. When the use of NetBIOS over TCP/IP has been disabled then the primary means for resolution of MS Windows machine names is via DNS and Active Directory. The following information assumes that your site is running NetBIOS over TCP/IP.

10.1. Features and Benefits

Someone once referred to the past in terms of: *They were the worst of times, they were the best of times. The more we look back, them more we long for what was and hope it never returns!*

For many MS Windows network administrators that statement sums up their feelings about NetBIOS networking precisely. For those who mastered NetBIOS networking it's fickle nature was just par for the course. For those who never quite managed to tame it's lusty features NetBIOS is like Paterson's Curse.

For those not familiar with botanical problems in Australia: Paterson's curse, *Echium plantagineum*, was introduced to Australia from Europe during the mid-nineteenth century. Since then it has spread rapidly. The high seed production, with densities of thousands of seeds per square metre, a seed longevity of more than seven years, and an ability to germinate at any time of year, given the right conditions, are some of the features which make it such a persistent weed.

In this chapter we explore vital aspects of SMB (Server Message Block) networking with a particular focus on SMB as implmented through running NetBIOS (Network Basic Input / Output System) over TCP/IP. Since Samba does NOT implement SMB or NetBIOS over any other protocols we need to know how to configure our network environment and simply remember to use nothing but TCP/IP on all our MS Windows network clients.

Samba provides the ability to implement a WINS (Windows Internetworking Name Server) and implements extensions to Microsoft's implementation of WINS. These extensions help Samba to affect stable WINS operations beyond the normal scope of MS WINS.

Please note that WINS is exclusively a service that applies only to those systems that run NetBIOS over TCP/IP. MS Windows 200x / XP have the capacity to turn off support for NetBIOS, in which case WINS is of no relevance. Samba-3 supports this also.

For those networks on which NetBIOS has been disabled (ie: WINS is NOT required) the use of DNS is necessary for host name resolution.

10.2. What is Browsing?

To most people browsing means that they can see the MS Windows and Samba servers in the Network Neighborhood, and when the computer icon for a particular server is clicked, it opens up and shows the shares and printers available on the target server.

What seems so simple is in fact a very complex interaction of different technologies. The technologies (or methods) employed in making all of this work includes:

- MS Windows machines register their presence to the network
- Machines announce themselves to other machines on the network
- One or more machine on the network collates the local announcements
- The client machine finds the machine that has the collated list of machines
- The client machine is able to resolve the machine names to IP addresses
- The client machine is able to connect to a target machine

The samba application that controls/manages browse list management and name resolution is called `nmbd`. The configuration parameters involved in `nmbd`'s operation are:

```
Browsing options:
-----
* os level
  lm announce
  lm interval
* preferred master
* local master
* domain master
  browse list
  enhanced browsing

Name Resolution Method:
-----
* name resolve order

WINS options:
-----
  dns proxy
  wins proxy
* wins server
* wins support
  wins hook
```

For Samba the WINS Server and WINS Support are mutually exclusive options. Those marked with an '*' are the only options that commonly MAY need to be

modified. Even if not one of these parameters is set `nmbd` will still do it's job.

10.3. Discussion

Firstly, all MS Windows networking uses SMB (Server Message Block) based messaging. SMB messaging may be implemented with or without NetBIOS. MS Windows 200x supports NetBIOS over TCP/IP for backwards compatibility. Microsoft are intent on phasing out NetBIOS support.

10.3.1. NetBIOS over TCP/IP

Samba implements NetBIOS, as does MS Windows NT / 200x / XP, by encapsulating it over TCP/IP. MS Windows products can do likewise. NetBIOS based networking uses broadcast messaging to affect browse list management. When running NetBIOS over TCP/IP this uses UDP based messaging. UDP messages can be broadcast or unicast.

Normally, only unicast UDP messaging can be forwarded by routers. The **remote announce** parameter to `smb.conf` helps to project browse announcements to remote network segments via unicast UDP. Similarly, the **remote browse sync** parameter of `smb.conf` implements browse list collation using unicast UDP.

Secondly, in those networks where Samba is the only SMB server technology wherever possible `nmbd` should be configured on one (1) machine as the WINS server. This makes it easy to manage the browsing environment. If each network segment is configured with it's own Samba WINS server, then the only way to get cross segment browsing to work is by using the **remote announce** and the **remote browse sync** parameters to your `smb.conf` file.

If only one WINS server is used for an entire multi-segment network then the use of the **remote announce** and the **remote browse sync** parameters should NOT be necessary.

As of Samba 3 WINS replication is being worked on. The bulk of the code has been committed, but it still needs maturation. This is NOT a supported feature of the Samba-3.0.0 release. Hopefully, this will become a supported feature of one of the samba-3 release series.

Right now samba WINS does not support MS-WINS replication. This means that when setting up Samba as a WINS server there must only be one `nmbd` configured as a WINS server on the network. Some sites have used multiple Samba WINS servers for redundancy (one server per subnet) and then used **remote browse sync** and **remote announce** to affect browse list collation across all segments. Note that this means clients will only resolve local names, and must be configured to use DNS to resolve names on other subnets in order to resolve the IP addresses of the servers they can see on other subnets. This setup is not recommended, but is mentioned as a practical consideration (ie: an 'if all else fails' scenario).

Lastly, take note that browse lists are a collection of unreliable broadcast messages that are repeated at intervals of not more than 15 minutes. This means that it will take time to establish a browse list and it can take up to 45 minutes to stabilise, particularly across network segments.

10.3.2. TCP/IP - without NetBIOS

All TCP/IP using systems use various forms of host name resolution. The primary methods for TCP/IP hostname resolutions involves either a static file (`/etc/hosts`) or DNS (the Domain Name System). DNS is the technology that makes the Internet

usable. DNS based host name resolution is supported by nearly all TCP/IP enabled systems. Only a few embedded TCP/IP systems do not support DNS.

When an MS Windows 200x / XP system attempts to resolve a host name to an IP address it follows a defined path:

1. Checks the `hosts` file. It is located in `C:\WinNT\System32\Drivers\etc`.
2. Does a DNS lookup
3. Checks the NetBIOS name cache
4. Queries the WINS server
5. Does a broadcast name lookup over UDP
6. Looks up entries in LMHOSTS. It is located in `C:\WinNT\System32\Drivers\etc`.

Windows 200x / XP can register it's host name with a Dynamic DNS server. You can force register with a Dynamic DNS server in Windows 200x / XP using: **`ipconfig /registerdns`**

With Active Directory (ADS), a correctly functioning DNS server is absolutely essential. In the absence of a working DNS server that has been correctly configured MS Windows clients and servers will be totally unable to locate each other, consequently network services will be severely impaired.

The use of Dynamic DNS is highly recommended with Active Directory, in which case the use of BIND9 is preferred for it's ability to adequately support the SRV (service) records that are needed for Active Directory.

10.3.3. DNS and Active Directory

Occasionally we hear from Unix network administrators who want to use a Unix based Dynamic DNS server in place of the Microsoft DNS server. While this might be desirable to some, the MS Windows 200x DNS server is auto-configured to work with Active Directory. It is possible to use BIND version 8 or 9, but it will almost certainly be necessary to create service records so that MS Active Directory clients can resolve host names to locate essential network services. The following are some of the default service records that Active Directory requires:

- `_ldap._tcp.pdc.ms-dcs.Domain`
This provides the address of the Windows NT PDC for the Domain.
- `_ldap._tcp.pdc.ms-dcs.DomainTree`
Resolves the addresses of Global Catalog servers in the domain.
- `_ldap._tcp.site.sites.writable.ms-dcs.Domain`
Provides list of domain controllers based on sites.
- `_ldap._tcp.writable.ms-dcs.Domain`
Enumerates list of domain controllers that have the writable copies of the Active Directory data store.
- `_ldap._tcp.GUID.domains.ms-dcs.DomainTree`
Entry used by MS Windows clients to locate machines using the Global Unique Identifier.
- `_ldap._tcp.Site.gc.ms-dcs.DomainTree`
Used by MS Windows clients to locate site configuration dependant Global Catalog server.

10.4. How Browsing Functions

MS Windows machines register their NetBIOS names (ie: the machine name for each service type in operation) on start up. The exact method by which this name registration takes place is determined by whether or not the MS Windows client/server

has been given a WINS server address, whether or not LMHOSTS lookup is enabled, or if DNS for NetBIOS name resolution is enabled, etc.

In the case where there is no WINS server all name registrations as well as name lookups are done by UDP broadcast. This isolates name resolution to the local subnet, unless LMHOSTS is used to list all names and IP addresses. In such situations Samba provides a means by which the samba server name may be forcibly injected into the browse list of a remote MS Windows network (using the **remote announce** parameter).

Where a WINS server is used, the MS Windows client will use UDP unicast to register with the WINS server. Such packets can be routed and thus WINS allows name resolution to function across routed networks.

During the startup process an election will take place to create a local master browser if one does not already exist. On each NetBIOS network one machine will be elected to function as the domain master browser. This domain browsing has nothing to do with MS security domain control. Instead, the domain master browser serves the role of contacting each local master browser (found by asking WINS or from LMHOSTS) and exchanging browse list contents. This way every master browser will eventually obtain a complete list of all machines that are on the network. Every 11-15 minutes an election is held to determine which machine will be the master browser. By the nature of the election criteria used, the machine with the highest uptime, or the most senior protocol version, or other criteria, will win the election as domain master browser.

Clients wishing to browse the network make use of this list, but also depend on the availability of correct name resolution to the respective IP address/addresses.

Any configuration that breaks name resolution and/or browsing intrinsic will annoy users because they will have to put up with protracted inability to use the network services.

Samba supports a feature that allows forced synchronisation of browse lists across routed networks using the **remote browse sync** parameter in the `smb.conf` file. This causes Samba to contact the local master browser on a remote network and to request browse list synchronisation. This effectively bridges two networks that are separated by routers. The two remote networks may use either broadcast based name resolution or WINS based name resolution, but it should be noted that the **remote browse sync** parameter provides browse list synchronisation - and that is distinct from name to address resolution, in other words, for cross subnet browsing to function correctly it is essential that a name to address resolution mechanism be provided. This mechanism could be via DNS, `/etc/hosts`, and so on.

10.4.1. Setting up WORKGROUP Browsing

To set up cross subnet browsing on a network containing machines in up to be in a WORKGROUP, not an NT Domain you need to set up one Samba server to be the Domain Master Browser (note that this is **NOT** the same as a Primary Domain Controller, although in an NT Domain the same machine plays both roles). The role of a Domain master browser is to collate the browse lists from local master browsers on all the subnets that have a machine participating in the workgroup. Without one machine configured as a domain master browser each subnet would be an isolated workgroup, unable to see any machines on any other subnet. It is the presence of a domain master browser that makes cross subnet browsing possible for a workgroup.

In an WORKGROUP environment the domain master browser must be a Samba server, and there must only be one domain master browser per workgroup name. To set up a Samba server as a domain master browser, set the following option in the [global] section of the `smb.conf` file :

```
domain master = yes
```

The domain master browser should also preferably be the local master browser for its own subnet. In order to achieve this set the following options in the [global] section of the `smb.conf` file :

```
domain master = yes
local master = yes
preferred master = yes
os level = 65
```

The domain master browser may be the same machine as the WINS server, if you require.

Next, you should ensure that each of the subnets contains a machine that can act as a local master browser for the workgroup. Any MS Windows NT/2K/XP/2003 machine should be able to do this, as will Windows 9x machines (although these tend to get rebooted more often, so it's not such a good idea to use these). To make a Samba server a local master browser set the following options in the [global] section of the `smb.conf` file :

```
domain master = no
local master = yes
preferred master = yes
os level = 65
```

Do not do this for more than one Samba server on each subnet, or they will war with each other over which is to be the local master browser.

The local master parameter allows Samba to act as a local master browser. The preferred master causes `nmbd` to force a browser election on startup and the `os level` parameter sets Samba high enough so that it should win any browser elections.

If you have an NT machine on the subnet that you wish to be the local master browser then you can disable Samba from becoming a local master browser by setting the following options in the [global] section of the `smb.conf` file :

```
domain master = no
local master = no
preferred master = no
os level = 0
```

10.4.2. Setting up DOMAIN Browsing

If you are adding Samba servers to a Windows NT Domain then you must not set up a Samba server as a domain master browser. By default, a Windows NT Primary Domain Controller for a Domain name is also the Domain master browser for that name, and many things will break if a Samba server registers the Domain master browser NetBIOS name (DOMAIN<1B>) with WINS instead of the PDC.

For subnets other than the one containing the Windows NT PDC you may set up Samba servers as local master browsers as described. To make a Samba server a local master browser set the following options in the [global] section of the `smb.conf` file :

:

```
domain master = no
local master = yes
preferred master = yes
os level = 65
```

If you wish to have a Samba server fight the election with machines on the same subnet you may set the `os level` parameter to lower levels. By doing this you can tune the order of machines that will become local master browsers if they are running. For more details on this see the section [Forcing samba to be the master browser](#) below.

If you have Windows NT machines that are members of the domain on all subnets, and you are sure they will always be running then you can disable Samba from taking part in browser elections and ever becoming a local master browser by setting following options in the `[global]` section of the `smb.conf` file :

```
domain master = no
local master = no
preferred master = no
os level = 0
```

10.4.3. Forcing samba to be the master

Who becomes the master browser is determined by an election process using broadcasts. Each election packet contains a number of parameters which determine what precedence (bias) a host should have in the election. By default Samba uses a very low precedence and thus loses elections to just about anyone else.

If you want Samba to win elections then just set the `os level` global option in `smb.conf` to a higher number. It defaults to 0. Using 34 would make it win all elections over every other system (except other samba systems!)

A `os level` of 2 would make it beat WfWg and Win95, but not MS Windows NT/2K Server. A MS Windows NT/2K Server domain controller uses level 32.

The maximum `os level` is 255

If you want samba to force an election on startup, then set the `preferred master` global option in `smb.conf` to `yes`. Samba will then have a slight advantage over other potential master browsers that are not preferred master browsers. Use this parameter with care, as if you have two hosts (whether they are windows 95 or NT or samba) on the same local subnet both set with `preferred master` to `yes`, then periodically and continually they will force an election in order to become the local master browser.

If you want samba to be a domain master browser, then it is recommended that you also set `preferred master` to `yes`, because samba will not become a domain master browser for the whole of your LAN or WAN if it is not also a local master browser on its own broadcast isolated subnet.

It is possible to configure two samba servers to attempt to become the domain master browser for a domain. The first server that comes up will be the domain master browser. All other samba servers will attempt to become the domain master browser every 5 minutes. They will find that another samba server is already the domain master browser and will fail. This provides automatic redundancy, should the current domain master browser fail.

10.4.4. Making samba the domain master

The domain master is responsible for collating the browse lists of multiple subnets so that browsing can occur between subnets. You can make samba act as the domain master by setting `domain master = yes` in `smb.conf`. By default it will not be a domain master.

Note that you should *not* set Samba to be the domain master for a workgroup that has the same name as an NT Domain.

When samba is the domain master and the master browser it will listen for master announcements (made roughly every twelve minutes) from local master browsers on other subnets and then contact them to synchronise browse lists.

If you want samba to be the domain master then I suggest you also set the `os level` high enough to make sure it wins elections, and set `preferred master` to `yes`, to get samba to force an election on startup.

Note that all your servers (including samba) and clients should be using a WINS server to resolve NetBIOS names. If your clients are only using broadcasting to resolve NetBIOS names, then two things will occur:

1. your local master browsers will be unable to find a domain master browser, as it will only be looking on the local subnet.
2. if a client happens to get hold of a domain-wide browse list, and a user attempts to access a host in that list, it will be unable to resolve the NetBIOS name of that host.

If, however, both samba and your clients are using a WINS server, then:

1. your local master browsers will contact the WINS server and, as long as samba has registered that it is a domain master browser with the WINS server, your local master browser will receive samba's ip address as its domain master browser.
2. when a client receives a domain-wide browse list, and a user attempts to access a host in that list, it will contact the WINS server to resolve the NetBIOS name of that host. as long as that host has registered its NetBIOS name with the same WINS server, the user will be able to see that host.

10.4.5. Note about broadcast addresses

If your network uses a "0" based broadcast address (for example if it ends in a 0) then you will strike problems. Windows for Workgroups does not seem to support a 0's broadcast and you will probably find that browsing and name lookups won't work.

10.4.6. Multiple interfaces

Samba now supports machines with multiple network interfaces. If you have multiple interfaces then you will need to use the `interfaces` option in `smb.conf` to configure them.

10.4.7. Use of the Remote Announce parameter

The `remote announce` parameter of `smb.conf` can be used to forcibly ensure that all the NetBIOS names on a network get announced to a remote network. The syntax of the `remote announce` parameter is:

```
remote announce = a.b.c.d [e.f.g.h] ...
```

._or._

```
remote announce = a.b.c.d/WORKGROUP [e.f.g.h/WORKGROUP] ...
```

where:

a.b.c.d and e.f.g.h is either the LMB (Local Master Browser) IP address or the broadcast address of the remote network. ie: the LMB is at 192.168.1.10, or the address could be given as 192.168.1.255 where the netmask is assumed to be 24 bits (255.255.255.0). When the remote announcement is made to the broadcast address of the remote network every host will receive our announcements. This is noisy and therefore undesirable but may be necessary if we do NOT know the IP address of the remote LMB.

WORKGROUP is optional and can be either our own workgroup or that of the remote network. If you use the workgroup name of the remote network then our NetBIOS machine names will end up looking like they belong to that workgroup, this may cause name resolution problems and should be avoided.

10.4.8. Use of the Remote Browse Sync parameter

The remote browse sync parameter of `smb.conf` is used to announce to another LMB that it must synchronise it's NetBIOS name list with our Samba LMB. It works ONLY if the Samba server that has this option is simultaneously the LMB on it's network segment.

The syntax of the remote browse sync parameter is:

```
remote browse sync = a.b.c.d
```

where a.b.c.d is either the IP address of the remote LMB or else is the network broadcast address of the remote segment.

10.5. WINS - The Windows Internetworking Name Server

Use of WINS (either Samba WINS `_or_` MS Windows NT Server WINS) is highly recommended. Every NetBIOS machine registers its name together with a `name.type` value for each of several types of service it has available. eg: It registers its name directly as a unique (the type `0x03`) name. It also registers its name if it is running the lanmanager compatible server service (used to make shares and printers available to other users) by registering the server (the type `0x20`) name.

All NetBIOS names are up to 15 characters in length. The `name.type` variable is added to the end of the name - thus creating a 16 character name. Any name that is shorter than 15 characters is padded with spaces to the 15th character. ie: All NetBIOS names are 16 characters long (including the `name.type` information).

WINS can store these 16 character names as they get registered. A client that wants to log onto the network can ask the WINS server for a list of all names that have registered the NetLogon service `name.type`. This saves broadcast traffic and greatly expedites logon processing. Since broadcast name resolution can not be used across network segments this type of information can only be provided via WINS `_or_` via statically configured `lmhosts` files that must reside on all clients in the absence of WINS.

WINS also serves the purpose of forcing browse list synchronisation by all LMB's. LMB's must synchronise their browse list with the DMB (domain master browser) and WINS helps the LMB to identify it's DMB. By definition this will work only

within a single workgroup. Note that the domain master browser has NOTHING to do with what is referred to as an MS Windows NT Domain. The later is a reference to a security environment while the DMB refers to the master controller for browse list information only.

Use of WINS will work correctly only if EVERY client TCP/IP protocol stack has been configured to use the WINS server/s. Any client that has not been configured to use the WINS server will continue to use only broadcast based name registration so that WINS may NEVER get to know about it. In any case, machines that have not registered with a WINS server will fail name to address lookup attempts by other clients and will therefore cause workstation access errors.

To configure Samba as a WINS server just add `wins support = yes` to the `smb.conf` file [globals] section.

To configure Samba to register with a WINS server just add `wins server = a.b.c.d` to your `smb.conf` file [globals] section.

IMPORTANT

Never use both `wins support = yes` together with `wins server = a.b.c.d` particularly not using it's own IP address. Specifying both will cause `nmbd` to refuse to start!

10.5.1. Setting up a WINS server

Either a Samba machine or a Windows NT Server machine may be set up as a WINS server. To set a Samba machine to be a WINS server you must add the following option to the `smb.conf` file on the selected machine : in the [globals] section add the line

```
wins support = yes
```

Versions of Samba prior to 1.9.17 had this parameter default to yes. If you have any older versions of Samba on your network it is strongly suggested you upgrade to a recent version, or at the very least set the parameter to 'no' on all these machines.

Machines with `wins support = yes` will keep a list of all NetBIOS names registered with them, acting as a DNS for NetBIOS names.

You should set up only ONE wins server. Do NOT set the `wins support = yes` option on more than one Samba server.

To set up a Windows NT Server as a WINS server you need to set up the WINS service - see your NT documentation for details. Note that Windows NT WINS Servers can replicate to each other, allowing more than one to be set up in a complex subnet environment. As Microsoft refuse to document these replication protocols Samba cannot currently participate in these replications. It is possible in the future that a Samba->Samba WINS replication protocol may be defined, in which case more than one Samba machine could be set up as a WINS server but currently only one Samba server should have the `wins support = yes` parameter set.

After the WINS server has been configured you must ensure that all machines participating on the network are configured with the address of this WINS server. If your WINS server is a Samba machine, fill in the Samba machine IP address in the **Primary WINS Server** field of the **Control Panel->Network->Protocols->TCP->WINS Server** dialogs in Windows 95 or Windows NT. To tell a Samba server the

IP address of the WINS server add the following line to the [global] section of all `smb.conf` files :

```
wins server = <name or IP address>
```

where <name or IP address> is either the DNS name of the WINS server machine or its IP address.

Note that this line **MUST NOT BE SET** in the `smb.conf` file of the Samba server acting as the WINS server itself. If you set both the `wins support = yes` option and the `wins server = <name>` option then `nmbd` will fail to start.

There are two possible scenarios for setting up cross subnet browsing. The first details setting up cross subnet browsing on a network containing Windows 95, Samba and Windows NT machines that are not configured as part of a Windows NT Domain. The second details setting up cross subnet browsing on networks that contain NT Domains.

10.5.2. WINS Replication

Samba-3 permits WINS replication through the use of the `wrepld` utility. This tool is not currently capable of being used as it is still in active development. As soon as this tool becomes moderately functional we will prepare man pages and enhance this section of the documentation to provide usage and technical details.

10.5.3. Static WINS Entries

New to Samba-3 is a tool called `winsedit` that may be used to add static WINS entries to the WINS database. This tool can be used also to modify entries existing in the WINS database.

The development of the `winsedit` tool was made necessary due to the migration of the older style `wins.dat` file into a new `tdb` binary backend data store.

10.6. Helpful Hints

The following hints should be carefully considered as they are stumbling points for many new network administrators.

10.6.1. Windows Networking Protocols

WARNING



Do NOT use more than one (1) protocol on MS Windows machines

A very common cause of browsing problems results from installing more than one protocol on an MS Windows machine.

Every NetBIOS machine takes part in a process of electing the LMB (and DMB) every 15 minutes. A set of election criteria is used to determine the order of precedence for winning this election process. A machine running Samba or Windows NT will be biased so that the most suitable machine will predictably win and thus retain its role.

The election process is "fought out" so to speak over every NetBIOS network interface. In the case of a Windows 9x machine that has both TCP/IP and IPX installed and has NetBIOS enabled over both protocols the election will be decided over both protocols. As often happens, if the Windows 9x machine is the only one with both protocols then the LMB may be won on the NetBIOS interface over the IPX protocol. Samba will then lose the LMB role as Windows 9x will insist it knows who the LMB is. Samba will then cease to function as an LMB and thus browse list operation on all TCP/IP only machines will fail.

Windows 95, 98, 98se, Me are referred to generically as Windows 9x. The Windows NT4, 2000, XP and 2003 use common protocols. These are roughly referred to as the WinNT family, but it should be recognised that 2000 and XP/2003 introduce new protocol extensions that cause them to behave differently from MS Windows NT4. Generally, where a server does NOT support the newer or extended protocol, these will fall back to the NT4 protocols.

The safest rule of all to follow it this - USE ONLY ONE PROTOCOL!

10.6.2. Name Resolution Order

Resolution of NetBIOS names to IP addresses can take place using a number of methods. The only ones that can provide NetBIOS name_type information are:

WINS: the best tool!

LMHOSTS: is static and hard to maintain.

Broadcast: uses UDP and can not resolve names across remote segments.

Alternative means of name resolution includes:

`/etc/hosts`: is static, hard to maintain, and lacks name_type info

DNS: is a good choice but lacks essential name_type info.

Many sites want to restrict DNS lookups and want to avoid broadcast name resolution traffic. The "name resolve order" parameter is of great help here. The syntax of the "name resolve order" parameter is:

```
name resolve order = wins lmhosts bcast host
```

or

```
name resolve order = wins lmhosts (eliminates bcast and host)
```

The default is:

```
name resolve order = host lmhost wins bcast
```

where "host" refers the the native methods used by the Unix system to implement the `gethostbyname()` function call. This is normally controlled by `/etc/host.conf`, `/etc/nsswitch.conf` and `/etc/resolv.conf`.

10.7. Technical Overview of browsing

SMB networking provides a mechanism by which clients can access a list of machines in a network, a so-called browse list. This list contains machines that are ready to offer file and/or print services to other machines within the network. Thus it does not include machines which aren't currently able to do server tasks. The browse

list is heavily used by all SMB clients. Configuration of SMB browsing has been problematic for some Samba users, hence this document.

MS Windows 2000 and later, as with Samba 3 and later, can be configured to not use NetBIOS over TCP/IP. When configured this way it is imperative that name resolution (using DNS/LDAP/ADS) be correctly configured and operative. Browsing will NOT work if name resolution from SMB machine names to IP addresses does not function correctly.

Where NetBIOS over TCP/IP is enabled use of a WINS server is highly recommended to aid the resolution of NetBIOS (SMB) names to IP addresses. WINS allows remote segment clients to obtain NetBIOS name_type information that can NOT be provided by any other means of name resolution.

10.7.1. Browsing support in samba

Samba facilitates browsing. The browsing is supported by nmbd and is also controlled by options in the `smb.conf` file. Samba can act as a local browse master for a workgroup and the ability to support domain logons and scripts is now available.

Samba can also act as a domain master browser for a workgroup. This means that it will collate lists from local browse masters into a wide area network server list. In order for browse clients to resolve the names they may find in this list, it is recommended that both samba and your clients use a WINS server.

Note that you should NOT set Samba to be the domain master for a workgroup that has the same name as an NT Domain: on each wide area network, you must only ever have one domain master browser per workgroup, regardless of whether it is NT, Samba or any other type of domain master that is providing this service.

NOTE



Nmbd can be configured as a WINS server, but it is not necessary to specifically use samba as your WINS server. MS Windows NT4, Server or Advanced Server 2000 or 2003 can be configured as your WINS server. In a mixed NT/2000/2003 server and samba environment on a Wide Area Network, it is recommended that you use the Microsoft WINS server capabilities. In a samba-only environment, it is recommended that you use one and only one Samba server as your WINS server.

To get browsing to work you need to run nmbd as usual, but will need to use the workgroup option in `smb.conf` to control what workgroup Samba becomes a part of.

Samba also has a useful option for a Samba server to offer itself for browsing on another subnet. It is recommended that this option is only used for 'unusual' purposes: announcements over the internet, for example. See remote announce in the `smb.conf` man page.

10.7.2. Problem resolution

If something doesn't work then hopefully the `log.nmb` file will help you track down the problem. Try a debug level of 2 or 3 for finding problems. Also note that the current browse list usually gets stored in text form in a file called `browse.dat`.

Note that if it doesn't work for you, then you should still be able to type the server name as `\\SERVER` in filemanager then hit enter and filemanager should display the

N2_A N2_B N2_C N2_D N3_A N3_B N3_C N3_D
(WINS)

Consisting of 3 subnets (1, 2, 3) connected by two routers (R1, R2) - these do not pass broadcasts. Subnet 1 has 5 machines on it, subnet 2 has 4 machines, subnet 3 has 4 machines. Assume for the moment that all these machines are configured to be in the same workgroup (for simplicity's sake). Machine N1.C on subnet 1 is configured as Domain Master Browser (ie. it will collate the browse lists for the workgroup). Machine N2.D is configured as WINS server and all the other machines are configured to register their NetBIOS names with it.

As all these machines are booted up, elections for master browsers will take place on each of the three subnets. Assume that machine N1.C wins on subnet 1, N2.B wins on subnet 2, and N3.D wins on subnet 3 - these machines are known as local master browsers for their particular subnet. N1.C has an advantage in winning as the local master browser on subnet 1 as it is set up as Domain Master Browser.

On each of the three networks, machines that are configured to offer sharing services will broadcast that they are offering these services. The local master browser on each subnet will receive these broadcasts and keep a record of the fact that the machine is offering a service. This list of records is the basis of the browse list. For this case, assume that all the machines are configured to offer services so all machines will be on the browse list.

For each network, the local master browser on that network is considered 'authoritative' for all the names it receives via local broadcast. This is because a machine seen by the local master browser via a local broadcast must be on the same network as the local master browser and thus is a 'trusted' and 'verifiable' resource. Machines on other networks that the local master browsers learn about when collating their browse lists have not been directly seen - these records are called 'non-authoritative'.

At this point the browse lists look as follows (these are the machines you would see in your network neighborhood if you looked in it on a particular network right now).

Table 10.1: Browse subnet example 1

Subnet	Browse Master	List
Subnet1	N1.C	N1.A, N1.B, N1.C, N1.D, N1.E
Subnet2	N2.B	N2.A, N2.B, N2.C, N2.D
Subnet3	N3.D	N3.A, N3.B, N3.C, N3.D

Note that at this point all the subnets are separate, no machine is seen across any of the subnets.

Now examine subnet 2. As soon as N2.B has become the local master browser it looks for a Domain master browser to synchronize its browse list with. It does this by querying the WINS server (N2.D) for the IP address associated with the NetBIOS name WORKGROUP<1B>. This name was registered by the Domain master browser (N1.C) with the WINS server as soon as it was booted.

Once N2.B knows the address of the Domain master browser it tells it that is the local master browser for subnet 2 by sending a MasterAnnouncement packet as a UDP port 138 packet. It then synchronizes with it by doing a NetServerEnum2 call. This tells the Domain Master Browser to send it all the server names it knows about. Once the domain master browser receives the MasterAnnouncement packet it schedules a synchronization request to the sender of that packet. After both

synchronizations are done the browse lists look like :

Table 10.2: Browse subnet example 2

Subnet	Browse Master	List
Subnet1	N1_C	N1_A, N1_B, N1_C, N1_D, N1_E, N2_A(*), N2_B(*), N2_C(*), N2_D(*)
Subnet2	N2_B	N2_A, N2_B, N2_C, N2_D, N1_A(*), N1_B(*), N1_C(*), N1_D(*), N1_E(*)
Subnet3	N3_D	N3_A, N3_B, N3_C, N3_D

Servers with a (*) after them are non-authoritative names.

At this point users looking in their network neighborhood on subnets 1 or 2 will see all the servers on both, users on subnet 3 will still only see the servers on their own subnet.

The same sequence of events that occurred for N2_B now occurs for the local master browser on subnet 3 (N3_D). When it synchronizes browse lists with the domain master browser (N1_A) it gets both the server entries on subnet 1, and those on subnet 2. After N3_D has synchronized with N1_C and vica-versa the browse lists look like.

Table 10.3: Browse subnet example 3

Subnet	Browse Master	List
Subnet1	N1_C	N1_A, N1_B, N1_C, N1_D, N1_E, N2_A(*), N2_B(*), N2_C(*), N2_D(*), N3_A(*), N3_B(*), N3_C(*), N3_D(*)
Subnet2	N2_B	N2_A, N2_B, N2_C, N2_D, N1_A(*), N1_B(*), N1_C(*), N1_D(*), N1_E(*)
Subnet3	N3_D	N3_A, N3_B, N3_C, N3_D, N1_A(*), N1_B(*), N1_C(*), N1_D(*), N1_E(*), N2_A(*), N2_B(*), N2_C(*), N2_D(*)

Servers with a (*) after them are non-authoritative names.

At this point users looking in their network neighborhood on subnets 1 or 3 will see all the servers on all subnets, users on subnet 2 will still only see the servers on subnets 1 and 2, but not 3.

Finally, the local master browser for subnet 2 (N2_B) will sync again with the domain master browser (N1_C) and will receive the missing server entries. Finally - and as a steady state (if no machines are removed or shut off) the browse lists will look like :

Servers with a (*) after them are non-authoritative names.

Synchronizations between the domain master browser and local master browsers will continue to occur, but this should be a steady state situation.

If either router R1 or R2 fails the following will occur:

1. Names of computers on each side of the inaccessible network fragments will be maintained for as long as 36 minutes, in the network neighbourhood lists.

Table 10.4: Browse subnet example 4

Subnet	Browse Master	List
Subnet1	N1_C	N1_A, N1_B, N1_C, N1_D, N1_E, N2_A(*), N2_B(*), N2_C(*), N2_D(*), N3_A(*), N3_B(*), N3_C(*), N3_D(*)
Subnet2	N2_B	N2_A, N2_B, N2_C, N2_D, N1_A(*), N1_B(*), N1_C(*), N1_D(*), N1_E(*), N3_A(*), N3_B(*), N3_C(*), N3_D(*)
Subnet3	N3_D	N3_A, N3_B, N3_C, N3_D, N1_A(*), N1_B(*), N1_C(*), N1_D(*), N1_E(*), N2_A(*), N2_B(*), N2_C(*), N2_D(*)

2. Attempts to connect to these inaccessible computers will fail, but the names will not be removed from the network neighbourhood lists.
3. If one of the fragments is cut off from the WINS server, it will only be able to access servers on its local subnet, by using subnet-isolated broadcast NetBIOS name resolution. The effects are similar to that of losing access to a DNS server.

10.8. Common Errors

Many questions are asked on the mailing lists regarding browsing. The majority of browsing problems originate out of incorrect configuration of NetBIOS name resolution. Some are of particular note.

10.8.1. How can one flush the Samba NetBIOS name cache without restarting samba?

Samba's `nmbd` process controls all browse list handling. Under normal circumstances it is safe to restart `nmbd`. This will effectively flush the samba NetBIOS name cache and cause it to be rebuilt. Note that this does NOT make certain that a rogue machine name will not re-appear in the browse list. When `nmbd` is taken out of service another machine on the network will become the browse master. This new list may still have the rogue entry in it. If you really want to clear a rogue machine from the list then every machine on the network will need to be shut down and restarted at after all machines are down. Failing a complete restart, the only other thing you can do is wait until the entry times out and is then flushed from the list. This may take a long time on some networks (months).

10.8.2. My client reports "This server is not configured to list shared resources"

Your guest account is probably invalid for some reason. Samba uses the guest account for browsing in `smbd`. Check that your guest account is valid.

See also guest account in the `smb.conf` man page.

11. Account Information Databases

Samba-3 implements a new capability to work concurrently with multiple account backends. The possible new combinations of password backends allows Samba-3 a degree of flexibility and scalability that previously could be achieved only with MS Windows Active Directory. This chapter describes the new functionality and how to get the most out of it.

In the course of development of Samba-3 a number of requests were received to provide the ability to migrate MS Windows NT4 SAM accounts to Samba-3 without the need to provide matching Unix/Linux accounts. We called this the *Non Unix Accounts (NUA)* capability. The intent was that an administrator could decide to use the *tdbsam* backend and by simply specifying *"passdb backend = tdbsam_nua, guest"* this would allow Samba-3 to implement a solution that did not use Unix accounts per se. Late in the development cycle the team doing this work hit upon some obstacles that prevents this solution from being used. Given the delays with Samba-3 release a decision was made to NOT deliver this functionality until a better method of recognising NT Group SIDs from NT User SIDs could be found. This feature may thus return during the life cycle for the Samba-3 series.

NOTE



Samba-3.0.0 does NOT support Non-Unix Account (NUA) operation.

11.1. Features and Benefits

Samba-3 provides for complete backwards compatibility with Samba-2.2.x functionality as follows:

BACKWARDS COMPATIBILITY BACKENDS

Plain Text: This option uses nothing but the Unix/Linux */etc/passwd* style backend. On systems that have PAM (Pluggable Authentication Modules) support all PAM modules are supported. The behaviour is just as it was with Samba-2.2.x, and the protocol limitations imposed by MS Windows clients apply likewise.

smbpasswd: This option allows continues use of the *smbpasswd* file that maintains a plain ASCII (text) layout that includes the MS Windows LanMan and NT encrypted passwords as well as a field that stores some account information. This form of password backend does NOT store any of the MS Windows NT/200x SAM (Security Account Manager) information needed to provide the extended controls that are needed for more comprehensive interoperation with MS Windows NT4 / 200x servers.

This backend should be used only for backwards compatibility with older versions of Samba. It may be deprecated in future releases.

ldapsam_compat (Samba-2.2 LDAP Compatibility): There is a password backend option that allows continued operation with a existing OpenLDAP backend that uses the Samba-2.2.x LDAP schema extension. This option is provided primarily as a migration tool, although there is no reason to force migration at this time. Note that this tool will eventually be deprecated.

Samba-3 introduces the following new password backend capabilities:

NEW BACKENDS

guest: This is *always* required as the last backend specified. It provides the ability to handle guest account requirements for access to resources like IPC\$ which is used for browsing.

tdbsam: This backend provides a rich database backend for local servers. This backend is NOT suitable for multiple domain controller (ie: PDC + one or more BDC) installations.

The *tdbsam* password backend stores the old *smbpasswd* information PLUS the extended MS Windows NT / 200x SAM information into a binary format TDB (trivial database) file. The inclusion of the extended information makes it possible for Samba-3 to implement the same account and system access controls that are possible with MS Windows NT4 and MS Windows 200x based systems. The inclusion of the *tdbsam* capability is a direct response to user requests to allow simple site operation without the overhead of the complexities of running OpenLDAP. It is recommended to use this only for sites that have fewer than 250 users. For larger sites or implementations the use of OpenLDAP or of Active Directory integration is strongly recommended.

ldapsam: This provides a rich directory backend for distributed account installation Samba-3 has a new and extended LDAP implementation that requires configuration of OpenLDAP with a new format samba schema. The new format schema file is included in the `~samba/examples/LDAP` directory.

The new LDAP implementation significantly expands the control abilities that were possible with prior versions of Samba. It is now possible to specify "per user" profile settings, home directories, account access controls, and much more. Corporate sites will see that the Samba-Team has listened to their requests both for capability and to allow greater scalability.

mysqsam (MySQL based backend): It is expected that the MySQL based SAM will be very popular in some corners. This database backend will be on considerable interest to sites that want to leverage existing MySQL technology.

xmlsam (XML based datafile): Allows the account and password data to be stored in an XML format data file. This backend can not be used for normal operation, it can only be used in conjunction with **pdbedit**'s `pdb2pdb` functionality. The DTD that is used might be subject to changes in the future.

The `xmlsam` option can be useful for account migration between database backends or backups. Use of this tool will allow the data to be edited before migration into another backend format.

nisplussam: The NIS+ based `passdb` backend. Takes name NIS domain as an optional argument. Only works with Sun NIS+ servers.

11.2. Technical Information

Old windows clients send plain text passwords over the wire. Samba can check these passwords by crypting them and comparing them to the hash stored in the unix user database.

Newer windows clients send encrypted passwords (so-called Lanman and NT hashes) over the wire, instead of plain text passwords. The newest clients will send only en-

encrypted passwords and refuse to send plain text passwords, unless their registry is tweaked.

These passwords can't be converted to unix style encrypted passwords. Because of that you can't use the standard unix user database, and you have to store the Lanman and NT hashes somewhere else.

In addition to differently encrypted passwords, windows also stores certain data for each user that is not stored in a unix user database. e.g: workstations the user may logon from, the location where the users' profile is stored, and so on. Samba retrieves and stores this information using a passdb backend. Commonly available backends are LDAP, plain text file, MySQL and nisplus. For more information, see the man page for `smb.conf` regarding the `passdb` backend parameter.

11.2.1. Important Notes About Security

The unix and SMB password encryption techniques seem similar on the surface. This similarity is, however, only skin deep. The unix scheme typically sends clear text passwords over the network when logging in. This is bad. The SMB encryption scheme never sends the cleartext password over the network but it does store the 16 byte hashed values on disk. This is also bad. Why? Because the 16 byte hashed values are a "password equivalent". You cannot derive the user's password from them, but they could potentially be used in a modified client to gain access to a server. This would require considerable technical knowledge on behalf of the attacker but is perfectly possible. You should thus treat the data stored in whatever passdb backend you use (`smbpasswd` file, `ldap`, `mysql`) as though it contained the cleartext passwords of all your users. Its contents must be kept secret, and the file should be protected accordingly.

Ideally we would like a password scheme that involves neither plain text passwords on the net nor on disk. Unfortunately this is not available as Samba is stuck with having to be compatible with other SMB systems (WinNT, WfWg, Win95 etc).

Windows NT 4.0 Service pack 3 changed the default setting so that plaintext passwords are disabled from being sent over the wire. This mandates either the use of encrypted password support or edit the Windows NT registry to re-enable plaintext passwords.

The following versions of MS Windows do not support full domain security protocols, although they may log onto a domain environment:

- MS DOS Network client 3.0 with the basic network redirector installed
- Windows 95 with the network redirector update installed
- Windows 98 [se]
- Windows Me

NOTE



MS Windows XP Home does not have facilities to become a domain member and it can not participate in domain logons.

The following versions of MS Windows fully support domain security protocols.

- Windows NT 3.5x
- Windows NT 4.0
- Windows 2000 Professional
- Windows 200x Server/Advanced Server

Windows XP Professional

All current release of Microsoft SMB/CIFS clients support authentication via the SMB Challenge/Response mechanism described here. Enabling clear text authentication does not disable the ability of the client to participate in encrypted authentication. Instead, it allows the client to negotiate either plain text _or_ encrypted password handling.

MS Windows clients will cache the encrypted password alone. Where plain text passwords are re-enabled, through the appropriate registry change, the plain text password is NEVER cached. This means that in the event that a network connections should become disconnected (broken) only the cached (encrypted) password will be sent to the resource server to affect a auto-reconnect. If the resource server does not support encrypted passwords the auto-reconnect will fail. *USE OF ENCRYPTED PASSWORDS IS STRONGLY ADVISED.*

11.2.1.1. Advantages of Encrypted Passwords

- Plain text passwords are not passed across the network. Someone using a network sniffer cannot just record passwords going to the SMB server.
- Plain text passwords are not stored anywhere in memory or on disk.
- WinNT doesn't like talking to a server that does not support encrypted passwords. It will refuse to browse the server if the server is also in user level security mode. It will insist on prompting the user for the password on each connection, which is very annoying. The only things you can do to stop this is to use SMB encryption.
- Encrypted password support allows automatic share (resource) reconnects.
- Encrypted passwords are essential for PDC/BDC operation.

11.2.1.2. Advantages of non-encrypted passwords

- Plain text passwords are not kept on disk, and are NOT cached in memory.
- Uses same password file as other unix services such as login and ftp
- Use of other services (such as telnet and ftp) which send plain text passwords over the net, so sending them for SMB isn't such a big deal.

11.2.2. Mapping User Identifiers between MS Windows and Unix

Every operation in Unix/Linux requires a user identifier (UID), just as in MS Windows NT4 / 200x this requires a Security Identifier (SID). Samba provides two means for mapping an MS Windows user to a Unix/Linux UID.

Firstly, all Samba SAM (Security Account Management database) accounts require a Unix/Linux UID that the account will map to. As users are added to the account information database samba-3 will call the add user script interface to add the account to the Samba host OS. In essence all accounts in the local SAM require a local user account.

The second way to affect Windows SID to Unix UID mapping is via the *idmap uid*, *idmap gid* parameters in *smb.conf*. Please refer to the man page for information about these parameters. These parameters are essential when mapping users from a remote SAM server.

11.3. Account Management Tools

Samba-3 provides two (2) tools for management of User and machine accounts. These tools are called *smbpasswd* and *pdbedit*. A third tool is under development but is

NOT expected to ship in time for Samba-3.0.0. The new tool will be a TCL/TK GUI tool that looks much like the MS Windows NT4 Domain User Manager - hopefully this will be announced in time for samba-3.0.1 release timing.

11.3.1. The **smbpasswd** Command

The **smbpasswd** utility is a utility similar to the **passwd** or **yppasswd** programs. It maintains the two 32 byte password fields in the **passwd** backend.

smbpasswd works in a client-server mode where it contacts the local **smbd** to change the user's password on its behalf. This has enormous benefits as follows:

smbpasswd has the capability to change passwords on Windows NT servers (this only works when the request is sent to the NT Primary Domain Controller if changing an NT Domain user's password).

smbpasswd can be used to:

- add* user or machine accounts
- delete* user or machine accounts
- enable* user or machine accounts
- disable* user or machine accounts
- set to NULL* user passwords
- manage interdomain trust accounts*

To run **smbpasswd** as a normal user just type:

```
$ smbpasswd
Old SMB password: secret
```

For secret type old value here - or hit return if there was no old password

```
New SMB Password: new secret
Repeat New SMB Password: new secret
```

If the old value does not match the current value stored for that user, or the two new values do not match each other, then the password will not be changed.

When invoked by an ordinary user it will only allow change of their own SMB password.

When run by root **smbpasswd** may take an optional argument, specifying the user name whose SMB password you wish to change. When run as root, **smbpasswd** does not prompt for or check the old password value, thus allowing root to set passwords for users who have forgotten their passwords.

smbpasswd is designed to work in the way familiar to UNIX users who use the **passwd** or **yppasswd** commands. While designed for administrative use, this tool provides essential user level password change capabilities.

For more details on using **smbpasswd** refer to the man page (the definitive reference).

11.3.2. The **pdbedit** Command

pdbedit is a tool that can be used only by root. It is used to manage the **passwd** backend. **pdbedit** can be used to:

- add, remove or modify user accounts
- listing user accounts
- migrate user accounts

The **pdbedit** tool is the only one that can manage the account security and policy settings. It is capable of all operations that `smbpasswd` can do as well as a super set of them.

One particularly important purpose of the **pdbedit** is to allow the migration of account information from one `passdb` backend to another. See the [XML](#) password backend section of this chapter.

The following is an example of the user account information that is stored in a `tdbsam` password backend. This listing was produced by running:

```
$ pdbedit -Lv met
Unix username:      met
NT username:
Account Flags:      [UX          ]
User SID:           S-1-5-21-1449123459-1407424037-3116680435-2004
Primary Group SID: S-1-5-21-1449123459-1407424037-3116680435-1201
Full Name:          Melissa E Terpstra
Home Directory:     \\frodo\met\Win9Profile
HomeDir Drive:      H:
Logon Script:       scripts\logon.bat
Profile Path:       \\frodo\Profiles\met
Domain:             MIDEARTH
Account desc:
Workstations:       melbelle
Munged dial:
Logon time:         0
Logoff time:        Mon, 18 Jan 2038 20:14:07 GMT
Kickoff time:       Mon, 18 Jan 2038 20:14:07 GMT
Password last set:  Sat, 14 Dec 2002 14:37:03 GMT
Password can change: Sat, 14 Dec 2002 14:37:03 GMT
Password must change: Mon, 18 Jan 2038 20:14:07 GMT
```

11.4. Password Backends

Samba-3 offers the greatest flexibility in backend account database design of any SMB/CIFS server technology available today. The flexibility is immediately obvious as one begins to explore this capability.

It is possible to specify not only multiple different password backends, but even multiple backends of the same type. For example, to use two different `tdbsam` databases:

```
[globals]
    passdb backend = tdbsam:/etc/samba/passdb.tdb, \
    tdbsam:/etc/samba/old-passdb.tdb, guest
```

11.4.1. Plain Text

Older versions of `samba` retrieved user information from the unix user database and eventually some other fields from the file `/etc/samba/smbpasswd` or `/etc/smbpasswd`. When password encryption is disabled, no SMB specific data is stored at all. Instead

all operations are conducted via the way that the samba host OS will access it's `/etc/passwd` database. eg: On Linux systems that is done via PAM.

11.4.2. smbpasswd - Encrypted Password Database

Traditionally, when configuring "encrypt passwords = yes" in Samba's `smb.conf` file, user account information such as username, LM/NT password hashes, password change times, and account flags have been stored in the `smbpasswd(5)` file. There are several disadvantages to this approach for sites with very large numbers of users (counted in the thousands).

- The first is that all lookups must be performed sequentially. Given that there are approximately two lookups per domain logon (one for a normal session connection such as when mapping a network drive or printer), this is a performance bottleneck for large sites. What is needed is an indexed approach such as is used in databases.
- The second problem is that administrators who desire to replicate a `smbpasswd` file to more than one Samba server were left to use external tools such as `rsync(1)` and `ssh(1)` and wrote custom, in-house scripts.
- And finally, the amount of information which is stored in an `smbpasswd` entry leaves no room for additional attributes such as a home directory, password expiration time, or even a Relative Identifier (RID).

As a result of these deficiencies, a more robust means of storing user attributes used by `smbd` was developed. The API which defines access to user accounts is commonly referred to as the `samdb` interface (previously this was called the `passdb` API, and is still so named in the Samba CVS trees).

Samba-3 provides an enhanced set of `passdb` backends that overcome the deficiencies of the `smbpasswd` plain text database. These are `tdbsam`, `ldapsam`, and `xmlsam`. Of these `ldapsam` will be of most interest to large corporate or enterprise sites.

11.4.3. tdbsam

Samba can store user and machine account data in a "TDB" (Trivial Database). Using this backend doesn't require any additional configuration. This backend is recommended for new installations that do not require LDAP.

As a general guide the Samba-Team do NOT recommend using the `tdbsam` backend for sites that have 250 or more users. Additionally, `tdbsam` is not capable of scaling for use in sites that require PDB/BDC implementations that requires replication of the account database. Clearly, for reason of scalability the use of `ldapsam` should be encouraged.

11.4.4. ldapsam

There are a few points to stress that the `ldapsam` does not provide. The LDAP support referred to in the this documentation does not include:

- A means of retrieving user account information from an Windows 200x Active Directory server.
- A means of replacing `/etc/passwd`.

The second item can be accomplished by using LDAP NSS and PAM modules. LGPL versions of these libraries can be obtained from PADL Software (<http://www.padl.com/>). More information about the configuration of these packages may be found at "LDAP, System Administration; Gerald Carter, O'Reilly; Chapter 6: Replacing NIS". Refer to <http://safari.oreilly.com/?XmlId=1-56592-491-6> for those

who might wish to know more about configuration and administration of an OpenLDAP server.

This document describes how to use an LDAP directory for storing Samba user account information traditionally stored in the `smbpasswd(5)` file. It is assumed that the reader already has a basic understanding of LDAP concepts and has a working directory server already installed. For more information on LDAP architectures and Directories, please refer to the following sites.

- OpenLDAP - <http://www.openldap.org/>
- iPlanet Directory Server - <http://iplanet.netscape.com/directory>

Two additional Samba resources which may prove to be helpful are

- The [Samba-PDC-LDAP-HOWTO](#) maintained by Ignacio Coupeau.
- The NT migration scripts from [IDEALX](#) that are geared to manage users and group in such a Samba-LDAP Domain Controller configuration.

11.4.4.1. Supported LDAP Servers

The LDAP `ldapsam` code has been developed and tested using the OpenLDAP 2.0 and 2.1 server and client libraries. The same code should work with Netscape's Directory Server and client SDK. However, there are bound to be compile errors and bugs. These should not be hard to fix. Please submit fixes via [Bug reporting facility](#).

11.4.4.2. Schema and Relationship to the RFC 2307 `posixAccount`

Samba 3.0 includes the necessary schema file for OpenLDAP 2.0 in `examples/LDAP/samba.schema`. The `sambaAccount` objectclass is given here:

```
objectclass ( 1.3.6.1.4.1.7165.2.2.3 NAME 'sambaAccount' SUP top AUXILIARY
  DESC 'Samba Auxilary Account'
  MUST ( uid $ rid )
  MAY ( cn $ lmPassword $ ntPassword $ pwdLastSet $ logonTime $
        logoffTime $ kickoffTime $ pwdCanChange $ pwdMustChange $ acctFlags $
        displayName $ smbHome $ homeDrive $ scriptPath $ profilePath $
        description $ userWorkstations $ primaryGroupID $ domain ))
```

The `samba.schema` file has been formatted for OpenLDAP 2.0/2.1. The OID's are owned by the Samba Team and as such is legal to be openly published. If you translate the schema to be used with Netscape DS, please submit the modified schema file as a patch to jerry@samba.org.

Just as the `smbpasswd` file is meant to store information which supplements a user's `/etc/passwd` entry, so is the `sambaAccount` object meant to supplement the UNIX user account information. A `sambaAccount` is a `STRUCTURAL` objectclass so it can be stored individually in the directory. However, there are several fields (e.g. `uid`) which overlap with the `posixAccount` objectclass outlined in RFC2307. This is by design.

In order to store all user account information (UNIX and Samba) in the directory, it is necessary to use the `sambaAccount` and `posixAccount` objectclasses in combination. However, `smbd` will still obtain the user's UNIX account information via the standard C library calls (e.g. `getpwnam()`, et. al.). This means that the Samba server must also have the LDAP NSS library installed and functioning correctly. This division of information makes it possible to store all Samba account information in LDAP, but still maintain UNIX account information in NIS while the network is transitioning to a full LDAP infrastructure.

11.4.4.3. OpenLDAP configuration

To include support for the `sambaAccount` object in an OpenLDAP directory server, first copy the `samba.schema` file to `slapd`'s configuration directory. The `samba.schema` file can be found in the directory `examples/LDAP` in the `samba` source distribution.

```
root# cp samba.schema /etc/openldap/schema/
```

Next, include the `samba.schema` file in `slapd.conf`. The `sambaAccount` object contains two attributes which depend upon other schema files. The `'uid'` attribute is defined in `cosine.schema` and the `'displayName'` attribute is defined in the `inetorgperson.schema` file. Both of these must be included before the `samba.schema` file.

```
## /etc/openldap/slapd.conf

## schema files (core.schema is required by default)
include          /etc/openldap/schema/core.schema

## needed for sambaAccount
include          /etc/openldap/schema/cosine.schema
include          /etc/openldap/schema/inetorgperson.schema
include          /etc/openldap/schema/samba.schema
include          /etc/openldap/schema/nis.schema
....
```

It is recommended that you maintain some indices on some of the most useful attributes, like in the following example, to speed up searches made on `sambaAccount` objectclasses (and possibly `posixAccount` and `posixGroup` as well).

```
# Indices to maintain
## required by OpenLDAP
index objectclass          eq

index cn                   pres,sub,eq
index sn                   pres,sub,eq
## required to support pdb_getsampwnam
index uid                  pres,sub,eq
## required to support pdb_getsambapwrid()
index displayName          pres,sub,eq

## uncomment these if you are storing posixAccount and
## posixGroup entries in the directory as well
##index uidNumber          eq
##index gidNumber          eq
##index memberUid          eq

index sambaSID              eq
index sambaPrimaryGroupSID eq
index sambaDomainName       eq
index default               sub
```

Create the new index by executing:

```
./sbin/slapindex -f slapd.conf
```

Remember to restart slapd after making these changes:

```
root# /etc/init.d/slapd restart
```

11.4.4.4. Initialise the LDAP database

Before you can add accounts to the LDAP database you must create the account containers that they will be stored in. The following LDIF file should be modified to match your needs (ie: Your DNS entries, etc.).

```
# Organization for Samba Base
dn: dc=plainjoe,dc=org
objectclass: dbObject
objectclass: organization
dc: plainjoe
o: Terpstra Org Network
description: The Samba-3 Network LDAP Example

# Organizational Role for Directory Management
db: cn=Manager,dc=plainjoe,dc=org
objectclass: organizationalRole
cn: Manager
description: Directory Manager

# Setting up container for users
dn: ou=People,dc=plainjoe,dc=org
objectclass: top
objectclass: organizationalUnit
ou: People

# Setting up admin handle for People OU
dn: cn=admin,ou=People,dc=plainjoe,dc=org
cn: admin
objectclass: top
objectclass: organizationalRole
objectclass: simpleSecurityObject
userPassword: {SSHA}c3ZM9tBaBo9autm1dL3waDS21+JSfQVz
```

The userPassword shown above should be generated using **slappasswd**.

The following command will then load the contents of the LDIF file into the LDAP database.

```
$ slapadd -v -l initldap.dif
```

Do not forget to secure your LDAP server with an adequate access control list, as well as an admin password.

NOTE



Before Samba can access the LDAP server you need to store the LDAP admin password into the Samba-3 `secrets.tdb` database by:

```
root# smbpasswd -w secret
```

11.4.4.5. Configuring Samba

The following parameters are available in `smb.conf` only if your version of samba was built with LDAP support. Samba automatically builds with LDAP support if the LDAP libraries are found.

- `passdb backend = ldapsam:url`
- `ldap ssl`
- `ldap admin dn`
- `ldap suffix`
- `ldap filter`
- `ldap machine suffix`
- `ldap user suffix`
- `ldap delete dn`
- `ldap passwd sync`
- `ldap trust ids`

These are described in the `smb.conf` man page and so will not be repeated here. However, a sample `smb.conf` file for use with an LDAP directory could appear as

```
## /usr/local/samba/lib/smb.conf
[global]
    security = user
    encrypt passwords = yes

    netbios name = TASHTEGO
    workgroup = NARNIA

    # ldap related parameters

    # define the DN to use when binding to the directory servers
    # The password for this DN is not stored in smb.conf. Rather it
    # must be set by using 'smbpasswd -w secretpw' to store the
    # passphrase in the secrets.tdb file. If the "ldap admin dn" values
    # change, this password will need to be reset.
    ldap admin dn = "cn=Samba Manager,ou=people,dc=samba,dc=org"

    # Define the SSL option when connecting to the directory
    # ('off', 'start tls', or 'on' (default))
    ldap ssl = start tls
```

```
# syntax: passdb backend = ldapsam:ldap://server-name[:port]
passdb backend = ldapsam:ldap://funball.samba.org, guest

# smbpasswd -x delete the entire dn-entry
ldap delete dn = no

# the machine and user suffix added to the base suffix
# wrote WITHOUT quotes. NULL suffixes by default
ldap user suffix = ou=People
ldap machine suffix = ou=Systems

# Trust unix account information in LDAP
# (see the smb.conf manpage for details)
ldap trust ids = Yes

# specify the base DN to use when searching the directory
ldap suffix = "ou=people,dc=samba,dc=org"

# generally the default ldap search filter is ok
# ldap filter = "(&(uid=%u)(objectclass=sambaAccount))"
```

11.4.4.6. Accounts and Groups management

As users accounts are managed thru the `sambaAccount` objectclass, you should modify your existing administration tools to deal with `sambaAccount` attributes.

Machines accounts are managed with the `sambaAccount` objectclass, just like users accounts. However, it's up to you to store those accounts in a different tree of your LDAP namespace: you should use `"ou=Groups,dc=plainjoe,dc=org"` to store groups and `"ou=People,dc=plainjoe,dc=org"` to store users. Just configure your NSS and PAM accordingly (usually, in the `/etc/ldap.conf` configuration file).

In Samba release 3.0, the group management system is based on posix groups. This means that Samba makes usage of the `posixGroup` objectclass. For now, there is no NT-like group system management (global and local groups).

11.4.4.7. Security and `sambaAccount`

There are two important points to remember when discussing the security of `sambaAccount` entries in the directory.

- *Never* retrieve the `lmPassword` or `ntPassword` attribute values over an unencrypted LDAP session.
- *Never* allow non-admin users to view the `lmPassword` or `ntPassword` attribute values.

These password hashes are clear text equivalents and can be used to impersonate the user without deriving the original clear text strings. For more information on the details of LM/NT password hashes, refer to the [Account Information Database](#) section of this chapter.

To remedy the first security issue, the `"ldap ssl"` `smb.conf` parameter defaults to require an encrypted session (`ldap ssl = on`) using the default port of 636 when contacting the directory server. When using an OpenLDAP server, it is possible to use the `StartTLS` LDAP extended operation in the place of LDAPS. In either case, you are strongly discouraged to disable this security (`ldap ssl = off`).

Note that the LDAPS protocol is deprecated in favor of the LDAPv3 StartTLS extended operation. However, the OpenLDAP library still provides support for the older method of securing communication between clients and servers.

The second security precaution is to prevent non-administrative users from harvesting password hashes from the directory. This can be done using the following ACL in `slapd.conf`:

```
## allow the "ldap admin dn" access, but deny everyone else
access to attrs=lmPassword,ntPassword
    by dn="cn=Samba Admin,ou=people,dc=plainjoe,dc=org" write
    by * none
```

11.4.4.8. LDAP special attributes for sambaAccounts

The `sambaAccount` objectclass is composed of the following attributes:

The majority of these parameters are only used when Samba is acting as a PDC of a domain (refer to the [Samba as a primary domain controller](#) chapter for details on how to configure Samba as a Primary Domain Controller). The following four attributes are only stored with the `sambaAccount` entry if the values are non-default values:

- smbHome
- scriptPath
- logonPath
- homeDrive

These attributes are only stored with the `sambaAccount` entry if the values are non-default values. For example, assume TASHTEGO has now been configured as a PDC and that `logon home = \\%L%\%u` was defined in its `smb.conf` file. When a user named "becky" logs on to the domain, the logon home string is expanded to `\\TASHTEGO\becky`. If the `smbHome` attribute exists in the entry "uid=becky,ou=people,dc=samba,dc=org", this value is used. However, if this attribute does not exist, then the value of the logon home parameter is used in its place. Samba will only write the attribute value to the directory entry if the value is something other than the default (e.g. `\\MOBY\becky`).

11.4.4.9. Example LDIF Entries for a sambaAccount

The following is a working LDIF with the inclusion of the `posixAccount` objectclass:

```
dn: uid=guest2, ou=people,dc=plainjoe,dc=org
ntPassword: 878D8014606CDA29677A44EFA1353FC7
pwdMustChange: 2147483647
primaryGroupID: 1201
lmPassword: 552902031BEDE9EFAAD3B435B51404EE
pwdLastSet: 1010179124
logonTime: 0
objectClass: sambaAccount
uid: guest2
kickoffTime: 2147483647
acctFlags: [UX      ]
logoffTime: 2147483647
rid: 19006
```

```
pwdCanChange: 0
```

The following is an LDIF entry for using both the `sambaAccount` and `posixAccount` objectclasses:

```
dn: uid=gcarter, ou=people,dc=plainjoe,dc=org
logonTime: 0
displayName: Gerald Carter
lmPassword: 552902031BEDE9EFAAD3B435B51404EE
primaryGroupID: 1201
objectClass: posixAccount
objectClass: sambaAccount
acctFlags: [UX          ]
userPassword: {crypt}BpM2ej8Rkzogo
uid: gcarter
uidNumber: 9000
cn: Gerald Carter
loginShell: /bin/bash
logoffTime: 2147483647
gidNumber: 100
kickoffTime: 2147483647
pwdLastSet: 1010179230
rid: 19000
homeDirectory: /home/tashtego/gcarter
pwdCanChange: 0
pwdMustChange: 2147483647
ntPassword: 878D8014606CDA29677A44EFA1353FC7
```

11.4.4.10. Password synchronisation

Since version 3.0 samba can update the non-samba (LDAP) password stored with an account. When using `pam_ldap`, this allows changing both unix and windows passwords at once.

The `ldap passwd sync` options can have the following values:

- yes** When the user changes his password, update `ntPassword`, `lmPassword` and the `password` fields.
- no** Only update `ntPassword` and `lmPassword`.
- only** Only update the LDAP password and let the LDAP server worry about the other fields. This option is only available when the LDAP library supports `LDAP_EXOP_X_MODIFY_PASSWD`.

More information can be found in the [smb.conf](#) manpage.

11.4.4.11. ldap trust ids

LDAP Performance can be improved by using the `ldap trust ids` parameter. See the [smb.conf](#) manpage for details.

11.4.5. MySQL

Every so often someone will come along with a great new idea. Storing of user accounts in an SQL backend is one of them. Those who want to do this are in the

best position to know what the specific benefits are to them. This may sound like a cop-out, but in truth we can not attempt to document every nitty little detail why certain things of marginal utility to the bulk of Samba users might make sense to the rest. In any case, the following instructions should help the determined SQL user to implement a working system.

11.4.5.1. Creating the database

You either can set up your own table and specify the field names to `pdb_mysql` (see below for the column names) or use the default table. The file `examples/pdb/mysql/mysql.dump` contains the correct queries to create the required tables. Use the command :

```
$ mysql -uusername -hhostname -ppassword databasename > /path/to/samba/examples/pdb/
```

11.4.5.2. Configuring

This plugin lacks some good documentation, but here is some short info:

Add a the following to the `passdb` backend variable in your `smb.conf`:

```
passdb backend = [other-plugins] mysql:identifier [other-plugins]
```

The identifier can be any string you like, as long as it doesn't collide with the identifiers of other plugins or other instances of `pdb_mysql`. If you specify multiple `pdb_mysql.so` entries in `passdb` backend, you also need to use different identifiers!

Additional options can be given thru the `smb.conf` file in the `[global]` section.

WARNING



Since the password for the `mysql` user is stored in the `smb.conf` file, you should make the the `smb.conf` file readable only to the user that runs `samba`. This is considered a security bug and will be fixed soon.

Names of the columns in this table(I've added column types those columns should have first):

Eventually, you can put a colon (:) after the name of each column, which should specify the column to update when updating the table. You can also specify nothing behind the colon - then the data from the field will not be updated.

11.4.5.3. Using plaintext passwords or encrypted password

I strongly discourage the use of plaintext passwords, however, you can use them:

If you would like to use plaintext passwords, set `'identifier:lanman pass column'` and `'identifier:nt pass column'` to `'NULL'` (without the quotes) and `'identifier:plain pass column'` to the name of the column containing the plaintext passwords.

If you use encrypted passwords, set the `'identifier:plain pass column'` to `'NULL'` (without the quotes). This is the default.

11.4.5.4. Getting non-column data from the table

It is possible to have not all data in the database and making some `'constant'`.

For example, you can set 'identifier:fullname column' to : **CONCAT(First_name,'
,Sur_name)**

Or, set 'identifier:workstations column' to : **NULL**

See the MySQL documentation for more language constructs.

11.4.6. XML

This module requires libxml2 to be installed.

The usage of `pdb_xml` is pretty straightforward. To export data, use:

```
$pdbedit -e xml:filename
```

(where filename is the name of the file to put the data in)

To import data, use: `$pdbedit -i xml:filename`

11.5. Common Errors

11.5.1. Users can not logon - Users not in Samba SAM

People forget to put their users in their backend and then complain samba won't authorize them.

11.5.2. Users are being added to the wrong backend database

A few complaints have been recieved from users that just moved to samba-3. The following `smb.conf` file entries were causing problems, new accounts were being added to the old `smbpasswd` file, not to the `tdbsam` `passdb.tdb` file:

```
[globals]
...
passdb backend = smbpasswd, tdbsam, guest
...
```

Samba will add new accounts to the first entry in the *passdb backend* parameter entry. If you want to update to the `tdbsam`, then change the entry to:

```
[globals]
...
passdb backend =tdbsam, smbpasswd, guest
...
```

11.5.3. auth methods does not work

If you explicitly set an 'auth methods' parameter, guest must be specified as the first entry on the line. Eg: `auth methods = guest sam`.

This is the exact opposite of the requirement for the `passdb` backed option, where it must be the *LAST* parameter on the line.

Table 11.1: Attributes in the sambaAccount objectclass (LDAP)

lmPassword	the LANMAN password 16-byte hash stored as a character representation of a hexadecimal string.
ntPassword	the NT password hash 16-byte stored as a character representation of a hexadecimal string.
pwdLastSet	The integer time in seconds since 1970 when the lmPassword and ntPassword attributes were last set.
acctFlags	string of 11 characters surrounded by square brackets [] representing account flags such as U (user), W(workstation), X(no password expiration), I(Domain trust account), H(Home dir required), S(Server trust account), and D(disabled).
logonTime	Integer value currently unused
logoffTime	Integer value currently unused
kickoffTime	Integer value currently unused
pwdCanChange	Integer value currently unused
pwdMustChange	Integer value currently unused
homeDrive	specifies the drive letter to which to map the UNC path specified by homeDirectory. The drive letter must be specified in the form "X:" where X is the letter of the drive to map. Refer to the "logon drive" parameter in the smb.conf(5) man page for more information.
scriptPath	The scriptPath property specifies the path of the user's logon script, .CMD, .EXE, or .BAT file. The string can be null. The path is relative to the netlogon share. Refer to the "logon script" parameter in the smb.conf(5) man page for more information.
profilePath	specifies a path to the user's profile. This value can be a null string, a local absolute path, or a UNC path. Refer to the "logon path" parameter in the smb.conf(5) man page for more information.
smbHome	The homeDirectory property specifies the path of the home directory for the user. The string can be null. If homeDrive is set and specifies a drive letter, homeDirectory should be a UNC path. The path must be a network UNC path of the form \\server\share\directory. This value can be a null string. Refer to the logon home parameter in the smb.conf man page for more information.
userWorkstation	character string value currently unused.
rid	the integer representation of the user's relative identifier (RID).
primaryGroupID	the relative identifier (RID) of the primary group of the user.
domain	domain the user is part of.

Table 11.2: Basic smb.conf options for MySQL passdb backend

Field	Contents
identifier:mysql host	host name, defaults to 'localhost'
identifier:mysql password	
identifier:mysql user	defaults to 'samba'
identifier:mysql database	defaults to 'samba'
identifier:mysql port	defaults to 3306
identifier:table	Name of the table containing users

Table 11.3: MySQL field names for MySQL passdb backend

Field	Type	Contents
identifier:logon time column	int(9)	
identifier:logoff time column	int(9)	
identifier:kickoff time column	int(9)	
identifier:pass last set time column	int(9)	
identifier:pass can change time column	int(9)	
identifier:pass must change time column	int(9)	
identifier:username column	varchar(255)	unix username
identifier:domain column	varchar(255)	NT domain user is part of
identifier:nt username column	varchar(255)	NT username
identifier:fullname column	varchar(255)	Full name of user
identifier:home dir column	varchar(255)	Unix homedir path
identifier:dir drive column	varchar(2)	Directory drive path (eg: 'H:')
identifier:logon script column	varchar(255)	Batch file to run on client side when logging on
identifier:profile path column	varchar(255)	Path of profile
identifier:acct desc column	varchar(255)	Some ASCII NT user data
identifier:workstations column	varchar(255)	Workstations user can logon to (or NULL for all)
identifier:unknown string column	varchar(255)	unknown string
identifier:munged dial column	varchar(255)	?
identifier:user sid column	varchar(255)	NT user SID
identifier:group sid column	varchar(255)	NT group ID
identifier:lanman pass column	varchar(255)	encrypted lanman password
identifier:nt pass column	varchar(255)	encrypted nt passwd
identifier:plain pass column	varchar(255)	plaintext password
identifier:acct control column	int(9)	nt user data
identifier:unknown 3 column	int(9)	unknown
identifier:logon divs column	int(9)	?
identifier:hours len column	int(9)	?
identifier:unknown 5 column	int(9)	unknown
identifier:unknown 6 column	int(9)	unknown

12. Mapping MS Windows and Unix Groups

Starting with Samba-3, new group mapping functionality is available to create associations between Windows group SIDs and UNIX groups. The `groupmap` subcommand included with the `net` tool can be used to manage these associations.

WARNING



The first immediate reason to use the group mapping on a Samba PDC, is that the domain admin group has been removed and should no longer be specified in `smb.conf`. This parameter was used to give the listed users membership in the `Domain Admins` Windows group which gave local admin rights on their workstations (in default configurations).

12.1. Features and Benefits

Samba allows the administrator to create MS Windows NT4 / 200x group accounts and to arbitrarily associate them with Unix/Linux group accounts.

Group accounts can be managed using the MS Windows NT4 or MS Windows 200x MMC tools so long as appropriate interface scripts have been provided to `smb.conf`

Administrators should be aware that where `smb.conf` group interface scripts make direct calls to the Unix/Linux system tools (eg: the shadow utilities, **groupadd**, **groupdel**, **groupmod**) then the resulting Unix/Linux group names will be subject to any limits imposed by these tools. If the tool does NOT allow upper case characters or space characters, then the creation of an MS Windows NT4 / 200x style group of Engineering Managers will attempt to create an identically named Unix/Linux group, an attempt that will of course fail!

There are several possible work-arounds for the operating system tools limitation. One method is to use a script that generates a name for the Unix/Linux system group that fits the operating system limits, and that then just passes the Unix/Linux group id (GID) back to the calling samba interface. This will provide a dynamic work-around solution.

Another work-around is to manually create a Unix/Linux group, then manually create the MS Windows NT4 / 200x group on the Samba server and then use the **net groupmap** tool to connect the two to each other.

12.2. Discussion

When installing MS Windows NT4 / 200x on a computer, the installation program creates default users and groups. Notably the **Administrators** group, and gives to that group privileges necessary privileges to perform essential system tasks. eg:

Ability to change the date and time or to kill any process (or close too) running on the local machine.

The 'Administrator' user is a member of the 'Administrators' group, and thus inherits 'Administrators' group privileges. If a 'joe' user is created to be a member of the 'Administrator' group, 'joe' has exactly the same rights as 'Administrator'.

When an MS Windows NT4 / W200x is made a domain member, the "Domain Admins" group of the PDC is added to the local 'Administrators' group of the workstation. Every member of the 'Domain Administrators' group inherits the rights of the local 'Administrators' group when logging on the workstation.

The following steps describe how to make samba PDC users members of the 'Domain Admins' group?

1. create a unix group (usually in `/etc/group`), let's call it `domadm`
2. add to this group the users that must be Administrators. For example if you want `joe, john` and `mary`, your entry in `/etc/group` will look like:

```
domadm:x:502:joe,john,mary
```

3. Map this `domadm` group to the "Domain Admins" group by running the command:

```
root# net groupmap add ntgroup="Domain Admins" unixgroup=domadm
```

The quotes around "Domain Admins" are necessary due to the space in the group name. Also make sure to leave no whitespace surrounding the equal character (=).

Now `joe, john` and `mary` are domain administrators!

It is possible to map any arbitrary UNIX group to any Windows NT4 / 200x group as well as making any UNIX group a Windows domain group. For example, if you wanted to include a UNIX group (e.g. `acct`) in a ACL on a local file or printer on a domain member machine, you would flag that group as a domain group by running the following on the Samba PDC:

```
root# net groupmap add rid=1000 ntgroup="Accounting" unixgroup=acct
```

Be aware that the RID parameter is a unsigned 32 bit integer that should normally start at 1000. However, this rid must not overlap with any RID assigned to a user. Verifying this is done differently depending on on the `passwd` backend you are using. Future versions of the tools may perform the verification automatically, but for now the burden is on you.

12.2.1. Example Configuration

You can list the various groups in the mapping database by executing `net groupmap list`. Here is an example:

```
root# net groupmap list
System Administrators (S-1-5-21-2547222302-1596225915-2414751004-1002) -> sysa
Domain Admins (S-1-5-21-2547222302-1596225915-2414751004-512) -> domadmin
Domain Users (S-1-5-21-2547222302-1596225915-2414751004-513) -> domuser
Domain Guests (S-1-5-21-2547222302-1596225915-2414751004-514) -> domguest
```

For complete details on `net groupmap`, refer to the `net(8)` man page.

12.3. Configuration Scripts

Everyone needs tools. Some of us like to create our own, others prefer to use canned tools (ie: prepared by someone else for general use).

12.3.1. Sample `smb.conf` add group script

A script to great complying group names for use by the samba group interfaces:

Example 12.3.1: `smbgrpadd.sh`

```
#!/bin/bash

# Add the group using normal system groupadd tool.
groupadd smbtmpgrp00

thegid='cat /etc/group | grep smbtmpgrp00 | cut -d ":" -f3'

# Now change the name to what we want for the MS Windows networking end
cat /etc/group | sed s/smbtmpgrp00/$1/g > /etc/group

# Now return the GID as would normally happen.
echo $thegid
exit 0
```

The `smb.conf` entry for the above script would look like:

```
add group script = /path_to_tool/smbgrpadd.sh %g
```

12.3.2. Script to configure Group Mapping

In our example we have created a Unix/Linux group called `ntadmin`. Our script will create the additional groups `Engineers`, `Marketoids`, `Gnomes`:

```
#!/bin/bash

net groupmap modify ntgroup="Domain Admins" unixgroup=ntadmin
net groupmap modify ntgroup="Domain Users" unixgroup=users
net groupmap modify ntgroup="Domain Guests" unixgroup=nobody
net groupmap modify ntgroup="Administrators" unixgroup=root
net groupmap modify ntgroup="Users" unixgroup=users
net groupmap modify ntgroup="Guests" unixgroup=nobody
net groupmap modify ntgroup="System Operators" unixgroup=sys
net groupmap modify ntgroup="Account Operators" unixgroup=root
net groupmap modify ntgroup="Backup Operators" unixgroup=bin
net groupmap modify ntgroup="Print Operators" unixgroup=lp
net groupmap modify ntgroup="Replicators" unixgroup=daemon
```

```
net groupmap modify ntgroup="Power Users" unixgroup=sys

#groupadd Engineers
#groupadd Marketoids
#groupadd Gnomes

#net groupmap add ntgroup="Engineers"  unixgroup=Engineers  type=d
#net groupmap add ntgroup="Marketoids"  unixgroup=Marketoids  type=d
#net groupmap add ntgroup="Gnomes"      unixgroup=Gnomes      type=d
```

Of course it is expected that the administrator will modify this to suit local needs. For information regarding the use of the **net groupmap** tool please refer to the man page.

12.4. Common Errors

At this time there are many little surprises for the unwary administrator. In a real sense it is imperative that every step of automated control scripts must be carefully tested manually before putting them into active service.

12.4.1. Adding Groups Fails

This is a common problem when the **groupadd** is called directly by the samba interface script for the add group script in the `smb.conf` file.

The most common cause of failure is an attempt to add an MS Windows group account that has either an upper case character and/or a space character in it.

There are three possible work-arounds. Firstly, use only group names that comply with the limitations of the Unix/Linux **groupadd** system tool. The second involves use of the script mentioned earlier in this chapter, and the third option is to manually create a Unix/Linux group account that can substitute for the MS Windows group name, then use the procedure listed above to map that group to the MS Windows group.

12.4.2. Adding MS Windows Groups to MS Windows Groups Fails

Samba-3 does NOT support nested groups from the MS Windows control environment.

13. File, Directory and Share Access Controls

Advanced MS Windows users are frequently perplexed when file, directory and share manipulation of resources shared via Samba do not behave in the manner they might expect. MS Windows network administrators are often confused regarding network access controls and what is the best way to provide users with the type of access they need while protecting resources from the consequences of untoward access capabilities.

Unix administrators frequently are not familiar with the MS Windows environment and in particular have difficulty in visualizing what the MS Windows user wishes to achieve in attempts to set file and directory access permissions.

The problem lies in the differences in how file and directory permissions and controls work between the two environments. This difference is one that Samba can not completely hide, even though it does try to make the chasm transparent.

POSIX Access Control List technology has been available (along with Extended Attributes) for Unix for many years, yet there is little evidence today of any significant use. This explains to some extent the slow adoption of ACLs into commercial Linux products. MS Windows administrators are astounded at this given that ACLs were a foundational capability of the now decade old MS Windows NT operating system.

The purpose of this chapter is to present each of the points of control that are possible with Samba-3 in the hope that this will help the network administrator to find the optimum method for delivering the best environment for MS Windows desktop users.

This is an opportune point to mention that it should be borne in mind that Samba was created to provide a means of interoperability and interchange of data between two operating environments that are quite different. It was never the intent to make Unix/Linux like MS Windows NT. Instead the purpose was an is to provide a sufficient level of exchange of data between the two environments. What is available today extends well beyond early plans and expectations, yet the gap continues to shrink.

13.1. Features and Benefits

Samba offers a lot of flexibility in file system access management. These are the key access control facilities present in Samba today:

SAMBA ACCESS CONTROL FACILITIES

- *Unix File and Directory Permissions*

Samba honours and implements Unix file system access controls. Users who access a Samba server will do so as a particular MS Windows user. This information is passed to the Samba server as part of the logon or connection setup process. Samba uses this user identity to validate whether or not the user should be given access to file system resources (files and directories). This chapter provides an overview for those to whom the Unix permissions and controls are a little strange or unknown.

- *Samba Share Definitions*
In configuring share settings and controls in the `smb.conf` file the network administrator can exercise over-rides to native file system permissions and behaviours. This can be handy and convenient to affect behaviour that is more like what MS Windows NT users expect but it is seldom the *best* way to achieve this. The basic options and techniques are described herein.
- *Samba Share ACLs*
Just like it is possible in MS Windows NT to set ACLs on shares themselves, so it is possible to do this in Samba. Very few people make use of this facility, yet it remains one of the easiest ways to affect access controls (restrictions) and can often do so with minimum invasiveness compared with other methods.
- *MS Windows ACLs through Unix POSIX ACLs*
The use of POSIX ACLs on Unix/Linux is possible ONLY if the underlying operating system supports them. If not, then this option will not be available to you. Current Unix technology platforms have native support for POSIX ACLs. There are patches for the Linux kernel that provide this also. Sadly, few Linux platforms ship today with native ACLs and Extended Attributes enabled. This chapter has pertinent information for users of platforms that support them.

13.2. File System Access Controls

Perhaps the most important recognition to be made is the simple fact that MS Windows NT4 / 200x / XP implement a totally divergent file system technology from what is provided in the Unix operating system environment. Firstly we should consider what the most significant differences are, then we shall look at how Samba helps to bridge the differences.

13.2.1. MS Windows NTFS Comparison with Unix File Systems

Samba operates on top of the Unix file system. This means it is subject to Unix file system conventions and permissions. It also means that if the MS Windows networking environment requires file system behaviour that differs from Unix file system behaviour then somehow Samba is responsible for emulating that in a transparent and consistent manner.

It is good news that Samba does this to a very large extent and on top of that provides a high degree of optional configuration to over-ride the default behaviour. We will look at some of these over-rides, but for the greater part we will stay within the bounds of default behaviour. Those wishing to explore to depths of control ability should review the `smb.conf` man page.

FILE SYSTEM FEATURE COMPARISON

Name Space MS Windows NT4 / 200x/ XP file names may be up to 254 characters long, Unix file names may be 1023 characters long. In MS Windows file extensions indicate particular file types, in Unix this is not so rigorously observed as all names are considered arbitrary.

What MS Windows calls a Folder, Unix calls a directory,

Case Sensitivity MS Windows file names are generally Upper Case if made up of 8.3 (ie: 8 character file name and 3 character extension. If longer than 8.3 file names are Case Preserving, and Case Insensitive.

Unix file and directory names are Case Sensitive and Case Preserving. Samba implements the MS Windows file name behaviour, but it does so as a user application. The Unix file system provides no mechanism to perform case

insensitive file name lookups. MS Windows does this by default. This means that Samba has to carry the processing overhead to provide features that are NOT native to the Unix operating system environment.

Consider the following, all are unique Unix names but one single MS Windows file name: MYFILE.TXT MyFile.txt myfile.txt So clearly, In an MS Windows file name space these three files CAN NOT co-exist! But in Unix they can. So what should Samba do if all three are present? Answer, the one that is lexically first will be accessible to MS Windows users, the others are invisible and unaccessible - any other solution would be suicidal.

Directory Separators MS Windows and DOS uses the back-slash '\' as a directory delimiter, Unix uses the forward-slash '/' as it's directory delimiter. This is transparently handled by Samba.

Drive Identification MS Windows products support a notion of drive letters, like **C:** to represent disk partitions. Unix has NO concept if separate identifiers for file partitions since each such file system is **mounted** to become part of the over-all directory tree. The Unix directory tree begins at '/', just like the root of a DOS drive is specified like **C:**.

File Naming Conventions MS Windows generally never experiences file names that begin with a '.', while in Unix these are commonly found in a user's home directory. Files that begin with a '.' are typically either start up files for various Unix applications, or they may be files that contain start-up configuration data.

Links and Short-Cuts MS Windows make use of "links and Short-Cuts" that are actually special types of files that will redirect an attempt to execute the file to the real location of the file. Unix knows of file and directory links, but they are entirely different from what MS Windows users are used to.

Symbolic links are files in Unix that contain the actual location of the data (file OR directory). An operation (like read or write) will operate directly on the file referenced. Symbolic links are also referred to as 'soft links'. A hard link is something that MS Windows is NOT familiar with. It allows one physical file to be known simulataneously by more than one file name.

There are many other subtle differences that may cause the MS Windows administrator some temporary discomfort in the process of becoming familiar with Unix/Linux. These are best left for a text that is dedicated to the purpose of Unix/Linux training/education.

13.2.2. Managing Directories

There are three basic operations for managing directories, **create**, **delete**, **rename**.

Table 13.1: Managing directories with unix and windows

Action	MS Windows Command	Unix Command
create	md folder	mkdir folder
delete	rd folder	rmdir folder
rename	rename oldname newname	mv oldname newname

13.2.3. File and Directory Access Control

The network administrator is strongly advised to read foundational training manuals and reference materials regarding file and directory permissions maintenance. Much can be achieved with the basic Unix permissions without having to resort to more

complex facilities like POSIX Access Control Lists (ACLs) or Extended Attributes (EAs).

Unix/Linux file and directory access permissions involves setting three (3) primary sets of data and one (1) control set. A Unix file listing looks as follows:-

```
jht@frodo:~/stuff> ls -la
total 632
drwxr-xr-x   13 jht  users      816 2003-05-12 22:56 .
drwxr-xr-x   37 jht  users     3800 2003-05-12 22:29 ..
d-----    2 jht  users      48 2003-05-12 22:29 mucho00
d--x--x--x   2 jht  users      48 2003-05-12 22:29 mucho01
dr-xr-xr-x   2 jht  users      48 2003-05-12 22:29 mucho02
drwxrwxrwx   2 jht  users      48 2003-05-12 22:29 mucho03
drw-rw-rw-   2 jht  users      48 2003-05-12 22:29 mucho04
d-w--w--w-   2 jht  users      48 2003-05-12 22:29 mucho05
dr--r--r--   2 jht  users      48 2003-05-12 22:29 mucho06
drwxrwxrwt   2 jht  users      48 2003-05-12 22:29 mucho07
drwsrwsrwx   2 jht  users      48 2003-05-12 22:29 mucho08
-----    1 jht  users     1242 2003-05-12 22:31 mydata00.lst
---x--x--x   1 jht  users     1674 2003-05-12 22:33 mydata01.lst
--w--w--w-   1 jht  users     7754 2003-05-12 22:33 mydata02.lst
--wx-wx-wx   1 jht  users    260179 2003-05-12 22:33 mydata03.lst
-r--r--r--   1 jht  users     21017 2003-05-12 22:32 mydata04.lst
-r-xr-xr-x   1 jht  users    206339 2003-05-12 22:32 mydata05.lst
-rw-rw-rw-   1 jht  users     41105 2003-05-12 22:32 mydata06.lst
-rwxrwxrwx   1 jht  users     19312 2003-05-12 22:32 mydata07.lst
jht@frodo:~/stuff>
```

The columns above represent (from left to right): permissions, no blocks used, owner, group, size (bytes), access date, access time, file name.

The permissions field is made up of:

```
JRV: Put this into a diagram of some sort
[ type ] [ users ] [ group ] [ others ] [File, Directory Permissions]
[ d | l ] [ r w x ] [ r w x ] [ r w x ]
| | | | | | | | | |
| | | | | | | | | |-----> Can Execute, List files
| | | | | | | | | |-----> Can Write, Create files
| | | | | | | | | |-----> Can Read, Read files
| | | | | | | | | |-----> Can Execute, List files
| | | | | | | | | |-----> Can Write, Create files
| | | | | | | | | |-----> Can Read, Read files
| | | | | | | | | |-----> Can Execute, List files
| | | | | | | | | |-----> Can Write, Create files
| | | | | | | | | |-----> Can Read, Read files
| | | | | | | | | |-----> Is a symbolic Link
|-----> Is a directory
```

Any bit flag may be unset. An unset bit flag is the equivalent of 'Can NOT' and is represented as a '-' character.

Additional possibilities in the [type] field are: c = character device, b = block device, p = pipe device, s = Unix Domain Socket.

Example 13.2.1: Example File

`-rwxr-x---` Means: The owner (user) can read, write, execute
the group can read and execute
everyone else can NOT do anything with it

The letters 'rwxXst' set permissions for the user, group and others as: read (r), write (w), execute (or access for directories) (x), r execute only if the file is a directory or already has execute permission for some user (X), set user or group ID on execution (s), sticky (t).

When the sticky bit is set on a directory, files in that directory may be unlinked (deleted) or renamed only by root or their owner. Without the sticky bit, anyone able to write to the directory can delete or rename files. The sticky bit is commonly found on directories, such as /tmp, that are world-writable.

When the set user or group ID bit (s) is set on a directory, then all files created within it will be owned by the user and/or group whose 'set user or group' bit is set. This can be very helpful in setting up directories that for which it is desired that all users who are in a group should be able to write to and read from a file, particularly when it is undesirable for that file to be exclusively owned by a user whose primary group is not the group that all such users belong to.

When a directory is set `drw-r-----` this means that the owner can read and create (write) files in it, but because the (x) execute flags are not set files can not be listed (seen) in the directory by anyone. The group can read files in the directory but can NOT create new files. NOTE: If files in the directory are set to be readable and writable for the group, then group members will be able to write to (or delete) them.

13.3. Share Definition Access Controls

The following parameters in the `smb.conf` file sections that define a share control or affect access controls. Before using any of the following options please refer to the man page for `smb.conf`.

13.3.1. User and Group Based Controls

User and group based controls can prove very useful. In some situations it is distinctly desirable to affect all file system operations as if a single user is doing this, the use of the force user and force group behaviour will achieve this. In other situations it may be necessary to affect a paranoia level of control to ensure that only particular authorised persons will be able to access a share or its contents, here the use of the valid users or the invalid users may be most useful.

As always, it is highly advisable to use the least difficult to maintain and the least ambiguous method for controlling access. Remember, that when you leave the scene someone else will need to provide assistance and if that person finds too great a mess, or if they do not understand what you have done then there is risk of Samba being removed and an alternative solution being adopted.

13.3.2. File and Directory Permissions Based Controls

The following file and directory permission based controls, if misused, can result in considerable difficulty to diagnose the cause of mis-configuration. Use them sparingly

Table 13.2: User and Group Based Controls

Control Parameter	Description - Action - Notes
admin users	List of users who will be granted administrative privileges on the share. They will do all file operations as the super-user (root). Any user in this list will be able to do anything they like on the share, irrespective of file permissions.
force group	Specifies a UNIX group name that will be assigned as the default primary group for all users connecting to this service.
force user	Specifies a UNIX user name that will be assigned as the default user for all users connecting to this service. This is useful for sharing files. Incorrect use can cause security problems.
guest ok	If this parameter is set for a service, then no password is required to connect to the service. Privileges will be those of the guest account.
invalid users	List of users that should not be allowed to login to this service.
only user	Controls whether connections with usernames not in the user list will be allowed.
read list	List of users that are given read-only access to a service. Users in this list will not be given write access, no matter what the read only option is set to.
username	Refer to the <code>smb.conf</code> man page for more information - this is a complex and potentially misused parameter.
valid users	List of users that should be allowed to login to this service.
write list	List of users that are given read-write access to a service.

and carefully. By gradually introducing each one by one undesirable side-effects may be detected. In the event of a problem, always comment all of them out and then gradually re-introduce them in a controlled fashion.

13.3.3. Miscellaneous Controls

The following are documented because of the prevalence of administrators creating inadvertent barriers to file access by not understanding the full implications of `smb.conf` file settings.

13.4. Access Controls on Shares

This section deals with how to configure Samba per share access control restrictions. By default samba sets no restrictions on the share itself. Restrictions on the share itself can be set on MS Windows NT4/200x/XP shares. This can be a very effective

Table 13.3: File and Directory Permission Based Controls

Control Parameter	Description - Action - Notes
create mask	Refer to the <code>smb.conf</code> man page.
directory mask	The octal modes used when converting DOS modes to UNIX modes when creating UNIX directories. See also: directory security mask.
dos filemode	Enabling this parameter allows a user who has write access to the file to modify the permissions on it.
force create mode	This parameter specifies a set of UNIX mode bit permissions that will always be set on a file created by Samba.
force directory mode	This parameter specifies a set of UNIX mode bit permissions that will always be set on a directory created by Samba.
force directory security mode	Controls UNIX permission bits modified when a Windows NT client is manipulating UNIX permissions on a directory
force security mode	Controls UNIX permission bits modified when a Windows NT client manipulates UNIX permissions.
hide unreadable	Prevents clients from seeing the existence of files that cannot be read.
hide unwriteable files	Prevents clients from seeing the existence of files that cannot be written to. Unwriteable directories are shown as usual.
nt acl support	This parameter controls whether <code>smbd</code> will attempt to map UNIX permissions into Windows NT access control lists.
security mask	Controls UNIX permission bits modified when a Windows NT client is manipulating the UNIX permissions on a file.

way to limit who can connect to a share. In the absence of specific restrictions the default setting is to allow the global user **Everyone** Full Control (ie: Full control, Change and Read).

At this time Samba does NOT provide a tool for configuring access control setting on the Share itself. Samba does have the capacity to store and act on access control settings, but the only way to create those settings is to use either the NT4 Server Manager or the Windows 200x MMC for Computer Management.

Samba stores the per share access control settings in a file called `share_info.tdb`. The location of this file on your system will depend on how samba was compiled. The default location for samba's tdb files is under `/usr/local/samba/var`. If the `tdbdump` utility has been compiled and installed on your system then you can examine the contents of this file by: `tdbdump share_info.tdb`.

13.4.1. Share Permissions Management

The best tool for the task is platform dependant. Choose the best tool for your environment.

Table 13.4: Other Controls

Control Parameter	Description - Action - Notes
case sensitive, default case, short preserve case	This means that all file name lookup will be done in a case sensitive manner. Files will be created with the precise filename Samba received from the MS Windows client.
csc policy	Client Side Caching Policy - parallels MS Windows client side file caching capabilities.
dont descend	Allows to specify a comma-delimited list of directories that the server should always show as empty.
dos filetime resolution	This option is mainly used as a compatibility option for Visual C++ when used against Samba shares.
dos filetimes	DOS and Windows allows users to change file time stamps if they can write to the file. POSIX semantics prevent this. This options allows DOS and Windows behaviour.
fake oplocks	Oplocks are the way that SMB clients get permission from a server to locally cache file operations. If a server grants an oplock then the client is free to assume that it is the only one accessing the file and it will aggressively cache file data.
hide dot files, hide files, veto files	Note: MS Windows Explorer allows over-ride of files marked as hidden so they will still be visible.
read only	If this parameter is yes, then users of a service may not create or modify files in the service's directory.
veto files	List of files and directories that are neither visible nor accessible.

13.4.1.1. Windows NT4 Workstation/Server

The tool you need to use to manage share permissions on a Samba server is the NT Server Manager. Server Manager is shipped with Windows NT4 Server products but not with Windows NT4 Workstation. You can obtain the NT Server Manager for MS Windows NT4 Workstation from Microsoft - see details below.

INSTRUCTIONS

1. Launch the NT4 Server Manager, click on the Samba server you want to administer, then from the menu select **Computer**, then click on the **Shared Directories** entry.
2. Now click on the share that you wish to manage, then click on the **Properties** tab, next click on the **Permissions** tab. Now you can add or change access control settings as you wish.

13.4.1.2. Windows 200x/XP

On MS Windows NT4/200x/XP system access control lists on the share itself are set using native tools, usually from filemanager. For example, in Windows 200x:

right click on the shared folder, then select **Sharing**, then click on **Permissions**. The default Windows NT4/200x permission allows *Everyone* Full Control on the Share.

MS Windows 200x and later all comes with a tool called the Computer Management snap-in for the Microsoft Management Console (MMC). This tool is located by clicking on **Control Panel -> Administrative Tools -> Computer Management**.

INSTRUCTIONS

1. After launching the MMC with the Computer Management snap-in, click on the menu item **Action**, select **Connect to another computer**. If you are not logged onto a domain you will be prompted to enter a domain login user identifier and a password. This will authenticate you to the domain. If you were already logged in with administrative privilege this step is not offered.
2. If the Samba server is not shown in the **Select Computer** box, then type in the name of the target Samba server in the field **Name:**. Now click on the **[+]** next to **System Tools**, then on the **[+]** next to **Shared Folders** in the left panel.
3. Now in the right panel, double-click on the share you wish to set access control permissions on. Then click on the tab **Share Permissions**. It is now possible to add access control entities to the shared folder. Do NOT forget to set what type of access (full control, change, read) you wish to assign for each entry.

WARNING



Be careful. If you take away all permissions from the *Everyone* user without removing this user then effectively no user will be able to access the share. This is a result of what is known as ACL precedence. ie: *Everyone* with *no* access means that *MaryK* who is part of the group *Everyone* will have no access even if this user is given explicit full control access.

13.5. MS Windows Access Control Lists and Unix Interoperability

13.5.1. Managing UNIX permissions Using NT Security Dialogs

Windows NT clients can use their native security settings dialog box to view and modify the underlying UNIX permissions.

Note that this ability is careful not to compromise the security of the UNIX host Samba is running on, and still obeys all the file permission rules that a Samba administrator can set.

NOTE



All access to Unix/Linux system file via Samba is controlled at the operating system file access control level. When trying to figure out file access problems it is vitally important to identify the identity of the Windows user as it is presented by Samba at the point of file access. This can best be determined from the Samba log files.

13.5.2. Viewing File Security on a Samba Share

From an NT4/2000/XP client, single-click with the right mouse button on any file or directory in a Samba mounted drive letter or UNC path. When the menu pops-up, click on the **Properties** entry at the bottom of the menu. This brings up the file properties dialog box. Click on the tab **Security** and you will see three buttons, **Permissions**, **Auditing**, and **Ownership**. The **Auditing** button will cause either an error message A requested privilege is not held by the client to appear if the user is not the NT Administrator, or a dialog which is intended to allow an Administrator to add auditing requirements to a file if the user is logged on as the NT Administrator. This dialog is non-functional with a Samba share at this time, as the only useful button, the **Add** button will not currently allow a list of users to be seen.

13.5.3. Viewing file ownership

Clicking on the **Ownership** button brings up a dialog box telling you who owns the given file. The owner name will be of the form :

"SERVER\user (Long name)"

Where SERVER is the NetBIOS name of the Samba server, user is the user name of the UNIX user who owns the file, and (Long name) is the descriptive string identifying the user (normally found in the GECOS field of the UNIX password database). Click on the **Close** button to remove this dialog.

If the parameter `nt acl support` is set to `false` then the file owner will be shown as the NT user "Everyone".

The **Take Ownership** button will not allow you to change the ownership of this file to yourself (clicking on it will display a dialog box complaining that the user you are currently logged onto the NT client cannot be found). The reason for this is that changing the ownership of a file is a privileged operation in UNIX, available only to the `root` user. As clicking on this button causes NT to attempt to change the ownership of a file to the current user logged into the NT client this will not work with Samba at this time.

There is an NT `chown` command that will work with Samba and allow a user with Administrator privilege connected to a Samba server as root to change the ownership of files on both a local NTFS filesystem or remote mounted NTFS or Samba drive. This is available as part of the `Seclib` NT security library written by Jeremy Allison of the Samba Team, available from the main Samba ftp site.

13.5.4. Viewing File or Directory Permissions

The third button is the **Permissions** button. Clicking on this brings up a dialog box that shows both the permissions and the UNIX owner of the file or directory. The owner is displayed in the form :

"SERVER\user (Long name)"

Where `SERVER` is the NetBIOS name of the Samba server, `user` is the user name of the UNIX user who owns the file, and `(Long name)` is the descriptive string identifying the user (normally found in the GECOS field of the UNIX password database).

If the parameter `nt acl support` is set to `false` then the file owner will be shown as the NT user "**Everyone**" and the permissions will be shown as NT "Full Control".

The permissions field is displayed differently for files and directories, so I'll describe the way file permissions are displayed first.

13.5.4.1. File Permissions

The standard UNIX user/group/world triple and the corresponding "read", "write", "execute" permissions triples are mapped by Samba into a three element NT ACL with the 'r', 'w', and 'x' bits mapped into the corresponding NT permissions. The UNIX world permissions are mapped into the global NT group **Everyone**, followed by the list of permissions allowed for UNIX world. The UNIX owner and group permissions are displayed as an NT **user** icon and an NT **local group** icon respectively followed by the list of permissions allowed for the UNIX user and group.

As many UNIX permission sets don't map into common NT names such as `read`, `change` or `full control` then usually the permissions will be prefixed by the words "**Special Access**" in the NT display list.

But what happens if the file has no permissions allowed for a particular UNIX user group or world component? In order to allow "no permissions" to be seen and modified then Samba overloads the NT "**Take Ownership**" ACL attribute (which has no meaning in UNIX) and reports a component with no permissions as having the NT "**O**" bit set. This was chosen of course to make it look like a zero, meaning zero permissions. More details on the decision behind this will be given below.

13.5.4.2. Directory Permissions

Directories on an NT NTFS file system have two different sets of permissions. The first set of permissions is the ACL set on the directory itself, this is usually displayed in the first set of parentheses in the normal "RW" NT style. This first set of permissions is created by Samba in exactly the same way as normal file permissions are, described above, and is displayed in the same way.

The second set of directory permissions has no real meaning in the UNIX permissions world and represents the **inherited** permissions that any file created within this directory would inherit.

Samba synthesises these inherited permissions for NT by returning as an NT ACL the UNIX permission mode that a new file created by Samba on this share would receive.

13.5.5. Modifying file or directory permissions

Modifying file and directory permissions is as simple as changing the displayed permissions in the dialog box, and clicking the **OK** button. However, there are limitations that a user needs to be aware of, and also interactions with the standard Samba permission masks and mapping of DOS attributes that need to also be taken into account.

If the parameter `nt acl support` is set to `false` then any attempt to set security permissions will fail with an "Access Denied" message.

The first thing to note is that the "**Add**" button will not return a list of users in Samba (it will give an error message of The remote procedure call failed and did not

execute). This means that you can only manipulate the current user/group/world permissions listed in the dialog box. This actually works quite well as these are the only permissions that UNIX actually has.

If a permission triple (either user, group, or world) is removed from the list of permissions in the NT dialog box, then when the **OK** button is pressed it will be applied as "no permissions" on the UNIX side. If you then view the permissions again the "no permissions" entry will appear as the NT "**O**" flag, as described above. This allows you to add permissions back to a file or directory once you have removed them from a triple component.

As UNIX supports only the "r", "w" and "x" bits of an NT ACL then if other NT security attributes such as "Delete access" are selected then they will be ignored when applied on the Samba server.

When setting permissions on a directory the second set of permissions (in the second set of parentheses) is by default applied to all files within that directory. If this is not what you want you must uncheck the **Replace permissions on existing files** checkbox in the NT dialog before clicking **OK**.

If you wish to remove all permissions from a user/group/world component then you may either highlight the component and click the **Remove** button, or set the component to only have the special **Take Ownership** permission (displayed as "**O**") highlighted.

13.5.6. Interaction with the standard Samba create mask parameters

There are four parameters to control interaction with the standard Samba create mask parameters. These are :

- security mask
- force security mode
- directory security mask
- force directory security mode

Once a user clicks **OK** to apply the permissions Samba maps the given permissions into a user/group/world r/w/x triple set, and then will check the changed permissions for a file against the bits set in the [security mask](#) parameter. Any bits that were changed that are not set to '1' in this parameter are left alone in the file permissions.

Essentially, zero bits in the security mask may be treated as a set of bits the user is *not* allowed to change, and one bits are those the user is allowed to change.

If not set explicitly this parameter is set to the same value as the [create mask](#) parameter. To allow a user to modify all the user/group/world permissions on a file, set this parameter to 0777.

Next Samba checks the changed permissions for a file against the bits set in the [force security mode](#) parameter. Any bits that were changed that correspond to bits set to '1' in this parameter are forced to be set.

Essentially, bits set in the force security mode parameter may be treated as a set of bits that, when modifying security on a file, the user has always set to be 'on'.

If not set explicitly this parameter is set to the same value as the [force create mode](#) parameter. To allow a user to modify all the user/group/world permissions on a file with no restrictions set this parameter to 000.

The security mask and force security mode parameters are applied to the change request in that order.

For a directory Samba will perform the same operations as described above for a file except using the parameter directory security mask instead of security mask, and force directory security mode parameter instead of force security mode.

The directory security mask parameter by default is set to the same value as the directory mask parameter and the force directory security mode parameter by default

is set to the same value as the force directory mode parameter.

In this way Samba enforces the permission restrictions that an administrator can set on a Samba share, whilst still allowing users to modify the permission bits within that restriction.

If you want to set up a share that allows users full control in modifying the permission bits on their files and directories and doesn't force any particular bits to be set 'on', then set the following parameters in the `smb.conf` file in that share specific section :

```
security mask = 0777
force security mode = 0
directory security mask = 0777
force directory security mode = 0
```

13.5.7. Interaction with the standard Samba file attribute mapping

Samba maps some of the DOS attribute bits (such as "read only") into the UNIX permissions of a file. This means there can be a conflict between the permission bits set via the security dialog and the permission bits set by the file attribute mapping.

One way this can show up is if a file has no UNIX read access for the owner it will show up as "read only" in the standard file attributes tabbed dialog. Unfortunately this dialog is the same one that contains the security info in another tab.

What this can mean is that if the owner changes the permissions to allow themselves read access using the security dialog, clicks **OK** to get back to the standard attributes tab dialog, and then clicks **OK** on that dialog, then NT will set the file permissions back to read-only (as that is what the attributes still say in the dialog). This means that after setting permissions and clicking **OK** to get back to the attributes dialog you should always hit **Cancel** rather than **OK** to ensure that your changes are not overridden.

13.6. Common Errors

File, Directory and Share access problems are very common on the mailing list. The following are examples taken from the mailing list in recent times.

13.6.1. Users can not write to a public share

'We are facing some troubles with file / directory permissions. I can log on the domain as admin user(root), and theres a public share, on which everyone needs to have permission to create / modify files, but only root can change the file, no one else can. We need to constantly go to server to `chgrp -R users *` and `chown -R nobody *` to allow others users to change the file.'

There are many ways to solve this problem, here are a few hints:

EXAMPLE SOLUTION:

1. Go to the top of the directory that is shared
2. Set the ownership to what ever public owner and group you want

```
find 'directory_name' -type d -exec chown user.group {} \;
find 'directory_name' -type d -exec chmod 6775 'directory_name'
find 'directory_name' -type f -exec chmod 0775 {} \;
find 'directory_name' -type f -exec chown user.group {} \;
```

NOTE



The above will set the 'sticky bit' on all directories. Read your Unix/Linux man page on what that does. It causes the OS to assign to all files created in the directories the ownership of the directory.

3. Directory is: /foodbar

```
$ chown jack. engr /foodbar
```

NOTE



This is the same as doing:

```
$ chown jack /foodbar  
$ chgrp engr /foodbar
```

4. Now do:

```
$ chmod 6775 /foodbar  
$ ls -al /foodbar/..
```

You should see:

```
drwsrwsr-x  2 jack  engr    48 2003-02-04 09:55 foodbar
```

5. Now do:

```
$ su - jill  
$ cd /foodbar  
$ touch Afile  
$ ls -al
```

You should see that the file Afile created by Jill will have ownership and permissions of Jack, as follows:

```
-rw-r--r--  1 jack  engr    0 2003-02-04 09:57 Afile
```

6. Now in your smb.conf for the share add:

```
force create mode = 0775  
force directory mode = 6775
```

NOTE



The above are only needed *if* your users are *not* members of the group you have used. ie: Within the OS do not have write permission on the directory.

An alternative is to set in the `smb.conf` entry for the share:

```
force user = jack  
force group = engr
```

13.6.2. I have set force user and samba still makes root the owner of all the files I touch!

When you have a user in 'admin users', samba will always do file operations for this user as *root*, even if force user has been set.

14. File and Record Locking

One area which causes trouble for many network administrators is locking. The extent of the problem is readily evident from searches over the internet.

14.1. Features and Benefits

Samba provides all the same locking semantics that MS Windows clients expect and that MS Windows NT4 / 200x servers provide also.

The term *locking* has exceptionally broad meaning and covers a range of functions that are all categorized under this one term.

Opportunistic locking is a desirable feature when it can enhance the perceived performance of applications on a networked client. However, the opportunistic locking protocol is not robust, and therefore can encounter problems when invoked beyond a simplistic configuration, or on extended, slow, or faulty networks. In these cases, operating system management of opportunistic locking and/or recovering from repetitive errors can offset the perceived performance advantage that it is intended to provide.

The MS Windows network administrator needs to be aware that file and record locking semantics (behaviour) can be controlled either in Samba or by way of registry settings on the MS Windows client.

NOTE



Sometimes it is necessary to disable locking control settings BOTH on the Samba server as well as on each MS Windows client!

14.2. Discussion

There are two types of locking which need to be performed by a SMB server. The first is *record locking* which allows a client to lock a range of bytes in an open file. The second is the *deny modes* that are specified when a file is open.

Record locking semantics under Unix is very different from record locking under Windows. Versions of Samba before 2.2 have tried to use the native `fcntl()` unix system call to implement proper record locking between different Samba clients. This can not be fully correct due to several reasons. The simplest is the fact that a Windows client is allowed to lock a byte range up to 2^{32} or 2^{64} , depending on the client OS. The unix locking only supports byte ranges up to 2^{31} . So it is not possible to correctly satisfy a lock request above 2^{31} . There are many more differences, too many to be listed here.

Samba 2.2 and above implements record locking completely independent of the underlying unix system. If a byte range lock that the client requests happens to fall into the range $0-2^{31}$, Samba hands this request down to the Unix system. All other locks can not be seen by unix anyway.

Strictly a SMB server should check for locks before every read and write call on a file. Unfortunately with the way `fcntl()` works this can be slow and may overstress the `rpc.lockd`. It is also almost always unnecessary as clients are supposed to independently make locking calls before reads and writes anyway if locking is important to them. By default Samba only makes locking calls when explicitly asked to by a client, but if you set `strict locking = yes` then it will make lock checking calls on every read and write.

You can also disable by range locking completely using `locking = no`. This is useful for those shares that don't support locking or don't need it (such as `cdroms`). In this case Samba fakes the return codes of locking calls to tell clients that everything is OK.

The second class of locking is the deny modes. These are set by an application when it opens a file to determine what types of access should be allowed simultaneously with its open. A client may ask for `DENY_NONE`, `DENY_READ`, `DENY_WRITE` or `DENY_ALL`. There are also special compatibility modes called `DENY_FCB` and `DENY_DOS`.

14.2.1. Opportunistic Locking Overview

Opportunistic locking (Oplocks) is invoked by the Windows file system (as opposed to an API) via registry entries (on the server AND client) for the purpose of enhancing network performance when accessing a file residing on a server. Performance is enhanced by caching the file locally on the client which allows:

Read-ahead: The client reads the local copy of the file, eliminating network latency

Write caching: The client writes to the local copy of the file, eliminating network latency

Lock caching: The client caches application locks locally, eliminating network latency

The performance enhancement of oplocks is due to the opportunity of exclusive access to the file - even if it is opened with `deny-none` - because Windows monitors the file's status for concurrent access from other processes.

WINDOWS DEFINES 4 KINDS OF OPLOCKS:

Level1 Oplock: The redirector sees that the file was opened with `deny none` (allowing concurrent access), verifies that no other process is accessing the file, checks that oplocks are enabled, then grants `deny-all/read-write/exclusive` access to the file. The client now performs operations on the cached local file.

If a second process attempts to open the file, the open is deferred while the redirector "breaks" the original oplock. The oplock break signals the caching client to write the local file back to the server, flush the local locks, and discard read-ahead data. The break is then complete, the deferred open is granted, and the multiple processes can enjoy concurrent file access as dictated by mandatory or byte-range locking options. However, if the original opening process opened the file with a share mode other than `deny-none`, then the second process is granted limited or no access, despite the oplock break.

Level2 Oplock: Performs like a level1 oplock, except caching is only operative for reads. All other operations are performed on the server disk copy of the file.

Filter Oplock: Does not allow write or delete file access

Batch Oplock: Manipulates file openings and closings - allows caching of file attributes

An important detail is that oplocks are invoked by the file system, not an application API. Therefore, an application can close an oplocked file, but the file system does not relinquish the oplock. When the oplock break is issued, the file system then simply closes the file in preparation for the subsequent open by the second process.

Opportunistic Locking is actually an improper name for this feature. The true benefit of this feature is client-side data caching, and oplocks is merely a notification mechanism for writing data back to the networked storage disk. The limitation of opportunistic locking is the reliability of the mechanism to process an oplock break (notification) between the server and the caching client. If this exchange is faulty (usually due to timing out for any number of reasons) then the client-side caching benefit is negated.

The actual decision that a user or administrator should consider is whether it is sensible to share amongst multiple users data that will be cached locally on a client. In many cases the answer is no. Deciding when to cache or not cache data is the real question, and thus "opportunistic locking" should be treated as a toggle for client-side caching. Turn it "ON" when client-side caching is desirable and reliable. Turn it "OFF" when client-side caching is redundant, unreliable, or counter-productive.

Opportunistic locking is by default set to "on" by Samba on all configured shares, so careful attention should be given to each case to determine if the potential benefit is worth the potential for delays. The following recommendations will help to characterize the environment where opportunistic locking may be effectively configured.

Windows Opportunistic Locking is a lightweight performance-enhancing feature. It is not a robust and reliable protocol. Every implementation of Opportunistic Locking should be evaluated as a tradeoff between perceived performance and reliability. Reliability decreases as each successive rule above is not enforced. Consider a share with oplocks enabled, over a wide area network, to a client on a South Pacific atoll, on a high-availability server, serving a mission-critical multi-user corporate database, during a tropical storm. This configuration will likely encounter problems with oplocks.

Oplocks can be beneficial to perceived client performance when treated as a configuration toggle for client-side data caching. If the data caching is likely to be interrupted, then oplock usage should be reviewed. Samba enables opportunistic locking by default on all shares. Careful attention should be given to the client usage of shared data on the server, the server network reliability, and the opportunistic locking configuration of each share. In mission critical high availability environments, data integrity is often a priority. Complex and expensive configurations are implemented to ensure that if a client loses connectivity with a file server, a failover replacement will be available immediately to provide continuous data availability.

Windows client failover behavior is more at risk of application interruption than other platforms because it is dependant upon an established TCP transport connection. If the connection is interrupted - as in a file server failover - a new session must be established. It is rare for Windows client applications to be coded to recover correctly from a transport connection loss, therefore most applications will experience some sort of interruption - at worst, abort and require restarting.

If a client session has been caching writes and reads locally due to opportunistic locking, it is likely that the data will be lost when the application restarts, or recovers from the TCP interrupt. When the TCP connection drops, the client state is lost. When the file server recovers, an oplock break is not sent to the client. In this case, the work from the prior session is lost. Observing this scenario with oplocks disabled, and the client was writing data to the file server real-time, then the failover will provide the data on disk as it existed at the time of the disconnect.

In mission critical high availability environments, careful attention should be given to opportunistic locking. Ideally, comprehensive testing should be done with all affected applications with oplocks enabled and disabled.

14.2.1.1. Exclusively Accessed Shares

Opportunistic locking is most effective when it is confined to shares that are exclusively accessed by a single user, or by only one user at a time. Because the true value of opportunistic locking is the local client caching of data, any operation that interrupts the caching mechanism will cause a delay.

Home directories are the most obvious examples of where the performance benefit of opportunistic locking can be safely realized.

14.2.1.2. Multiple-Accessed Shares or Files

As each additional user accesses a file in a share with opportunistic locking enabled, the potential for delays and resulting perceived poor performance increases. When multiple users are accessing a file on a share that has oplocks enabled, the management impact of sending and receiving oplock breaks, and the resulting latency while other clients wait for the caching client to flush data, offset the performance gains of the caching user.

As each additional client attempts to access a file with oplocks set, the potential performance improvement is negated and eventually results in a performance bottleneck.

14.2.1.3. Unix or NFS Client Accessed Files

Local Unix and NFS clients access files without a mandatory file locking mechanism. Thus, these client platforms are incapable of initiating an oplock break request from the server to a Windows client that has a file cached. Local Unix or NFS file access can therefore write to a file that has been cached by a Windows client, which exposes the file to likely data corruption.

If files are shared between Windows clients, and either local Unix or NFS users, then turn opportunistic locking off.

14.2.1.4. Slow and/or Unreliable Networks

The biggest potential performance improvement for opportunistic locking occurs when the client-side caching of reads and writes delivers the most differential over sending those reads and writes over the wire. This is most likely to occur when the network is extremely slow, congested, or distributed (as in a WAN). However, network latency also has a very high impact on the reliability of the oplock break mechanism, and thus increases the likelihood of encountering oplock problems that more than offset the potential perceived performance gain. Of course, if an oplock break never has to be sent, then this is the most advantageous scenario to utilize opportunistic locking.

If the network is slow, unreliable, or a WAN, then do not configure opportunistic locking if there is any chance of multiple users regularly opening the same file.

14.2.1.5. Multi-User Databases

Multi-user databases clearly pose a risk due to their very nature - they are typically heavily accessed by numerous users at random intervals. Placing a multi-user database on a share with opportunistic locking enabled will likely result in a locking management bottleneck on the Samba server. Whether the database application is developed in-house or a commercially available product, ensure that the share has opportunistic locking disabled.

14.2.1.6. PDM Data Shares

Process Data Management (PDM) applications such as IMAN, Enovia, and Clearcase, are increasing in usage with Windows client platforms, and therefore SMB data stores. PDM applications manage multi-user environments for critical data security and access. The typical PDM environment is usually associated with sophisticated client design applications that will load data locally as demanded. In addition, the PDM application will usually monitor the data-state of each client. In this case, client-side data caching is best left to the local application and PDM server to negotiate and maintain. It is appropriate to eliminate the client OS from any caching tasks, and the server from any oplock management, by disabling opportunistic locking on the share.

14.2.1.7. Beware of Force User

Samba includes an `smb.conf` parameter called `force user` that changes the user accessing a share from the incoming user to whatever user is defined by the `smb.conf` variable. If opportunistic locking is enabled on a share, the change in user access causes an oplock break to be sent to the client, even if the user has not explicitly loaded a file. In cases where the network is slow or unreliable, an oplock break can become lost without the user even accessing a file. This can cause apparent performance degradation as the client continually reconnects to overcome the lost oplock break.

Avoid the combination of the following:

- `force user` in the `smb.conf` share configuration.
- Slow or unreliable networks
- Opportunistic Locking Enabled

14.2.1.8. Advanced Samba Opportunistic Locking Parameters

Samba provides opportunistic locking parameters that allow the administrator to adjust various properties of the oplock mechanism to account for timing and usage levels. These parameters provide good versatility for implementing oplocks in environments where they would likely cause problems. The parameters are: oplock break wait time, oplock contention limit.

For most users, administrators, and environments, if these parameters are required, then the better option is to simply turn oplocks off. The samba SWAT help text for both parameters reads "DO NOT CHANGE THIS PARAMETER UNLESS YOU HAVE READ AND UNDERSTOOD THE SAMBA OPLOCK CODE." This is good advice.

14.2.1.9. Mission Critical High Availability

In mission critical high availability environments, data integrity is often a priority. Complex and expensive configurations are implemented to ensure that if a client loses connectivity with a file server, a failover replacement will be available immediately to provide continuous data availability.

Windows client failover behavior is more at risk of application interruption than other platforms because it is dependant upon an established TCP transport connection. If the connection is interrupted - as in a file server failover - a new session must be established. It is rare for Windows client applications to be coded to recover correctly from a transport connection loss, therefore most applications will experience some sort of interruption - at worst, abort and require restarting.

If a client session has been caching writes and reads locally due to opportunistic locking, it is likely that the data will be lost when the application restarts, or recovers from the TCP interrupt. When the TCP connection drops, the client state is lost. When the file server recovers, an oplock break is not sent to the client. In this case, the work from the prior session is lost. Observing this scenario with oplocks disabled, and the client was writing data to the file server real-time, then the failover will provide the data on disk as it existed at the time of the disconnect.

In mission critical high availability environments, careful attention should be given to opportunistic locking. Ideally, comprehensive testing should be done with all affected applications with oplocks enabled and disabled.

14.3. Samba Opportunistic Locking Control

Opportunistic Locking is a unique Windows file locking feature. It is not really file locking, but is included in most discussions of Windows file locking, so is considered a defacto locking feature. Opportunistic Locking is actually part of the Windows client file caching mechanism. It is not a particularly robust or reliable feature when implemented on the variety of customized networks that exist in enterprise computing.

Like Windows, Samba implements Opportunistic Locking as a server-side component of the client caching mechanism. Because of the lightweight nature of the Windows feature design, effective configuration of Opportunistic Locking requires a good understanding of its limitations, and then applying that understanding when configuring data access for each particular customized network and client usage state.

Opportunistic locking essentially means that the client is allowed to download and cache a file on their hard drive while making changes; if a second client wants to access the file, the first client receives a break and must synchronise the file back to the server. This can give significant performance gains in some cases; some programs insist on synchronising the contents of the entire file back to the server for a single change.

Level1 Oplocks (aka just plain "oplocks") is another term for opportunistic locking.

Level2 Oplocks provides opportunistic locking for a file that will be treated as *read only*. Typically this is used on files that are read-only or on files that the client has no initial intention to write to at time of opening the file.

Kernel Oplocks are essentially a method that allows the Linux kernel to co-exist with Samba's oplocked files, although this has provided better integration of MS Windows network file locking with the underlying OS, SGI IRIX and Linux are the only two OS's that are oplock aware at this time.

Unless your system supports kernel oplocks, you should disable oplocks if you are accessing the same files from both Unix/Linux and SMB clients. Regardless, oplocks should always be disabled if you are sharing a database file (e.g., Microsoft Access) between multiple clients, as any break the first client receives will affect synchronisation of the entire file (not just the single record), which will result in a noticeable performance impairment and, more likely, problems accessing the database in the first place. Notably, Microsoft Outlook's personal folders (*.pst) react very badly to oplocks. If in doubt, disable oplocks and tune your system from that point.

If client-side caching is desirable and reliable on your network, you will benefit from turning on oplocks. If your network is slow and/or unreliable, or you are sharing your files among other file sharing mechanisms (e.g., NFS) or across a WAN, or multiple people will be accessing the same files frequently, you probably will not benefit from the overhead of your client sending oplock breaks and will instead want to disable oplocks for the share.

Another factor to consider is the perceived performance of file access. If oplocks provide no measurable speed benefit on your network, it might not be worth the hassle of dealing with them.

14.3.1. Example Configuration

In the following we examine two distinct aspects of samba locking controls.

14.3.1.1. Disabling Oplocks

You can disable oplocks on a per-share basis with the following:

```
[acctdata]
  oplocks = False
  level2 oplocks = False
```

The default oplock type is Level1. Level2 Oplocks are enabled on a per-share basis in the `smb.conf` file.

Alternately, you could disable oplocks on a per-file basis within the share:

```
veto oplock files = /*.mdb/*.MDB/*.dbf/*.DBF/
```

If you are experiencing problems with oplocks as apparent from Samba's log entries, you may want to play it safe and disable oplocks and level2 oplocks.

14.3.1.2. Disabling Kernel OpLocks

Kernel OpLocks is an `smb.conf` parameter that notifies Samba (if the UNIX kernel has the capability to send a Windows client an oplock break) when a UNIX process is attempting to open the file that is cached. This parameter addresses sharing files between UNIX and Windows with Oplocks enabled on the Samba server: the UNIX process can open the file that is Oplocked (cached) by the Windows client and the `smbd` process will not send an oplock break, which exposes the file to the risk of data corruption. If the UNIX kernel has the ability to send an oplock break, then the kernel oplocks parameter enables Samba to send the oplock break. Kernel oplocks are enabled on a per-server basis in the `smb.conf` file.

```
[global]
kernel oplocks = yes
```

The default is "no".

Veto OpLocks is an `smb.conf` parameter that identifies specific files for which Oplocks are disabled. When a Windows client opens a file that has been configured for veto oplocks, the client will not be granted the oplock, and all operations will be executed on the original file on disk instead of a client-cached file copy. By explicitly identifying files that are shared with UNIX processes, and disabling oplocks for those files, the server-wide Oplock configuration can be enabled to allow Windows clients to utilize the performance benefit of file caching without the risk of data corruption. Veto Oplocks can be enabled on a per-share basis, or globally for the entire server, in the `smb.conf` file:

Example Veto OpLock Settings
[global]

```
veto oplock files = /filename.htm/*.txt/
```

```
[share_name]
```

```
veto oplock files = /*.exe/filename.ext/
```

Oplock break wait time is an `smb.conf` parameter that adjusts the time interval for Samba to reply to an oplock break request. Samba recommends "DO NOT CHANGE THIS PARAMETER UNLESS YOU HAVE READ AND UNDERSTOOD THE SAMBA OPLOCK CODE." Oplock Break Wait Time can only be configured globally in the `smb.conf` file:

```
[global]
```

```
oplock break wait time = 0 (default)
```

Oplock break contention limit is an `smb.conf` parameter that limits the response of the Samba server to grant an oplock if the configured number of contending clients reaches the limit specified by the parameter. Samba recommends "DO NOT CHANGE THIS PARAMETER UNLESS YOU HAVE READ AND UNDERSTOOD THE SAMBA OPLOCK CODE." Oplock Break Contention Limit can be enable on a per-share basis, or globally for the entire server, in the `smb.conf` file:

```
[global]
```

```
oplock break contention limit = 2 (default)
```

```
[share_name]
```

```
oplock break contention limit = 2 (default)
```

14.4. MS Windows Opportunistic Locking and Caching Controls

There is a known issue when running applications (like Norton Anti-Virus) on a Windows 2000/ XP workstation computer that can affect any application attempting to access shared database files across a network. This is a result of a default setting configured in the Windows 2000/XP operating system known as *Opportunistic Locking*. When a workstation attempts to access shared data files located on another Windows 2000/XP computer, the Windows 2000/XP operating system will attempt to increase performance by locking the files and caching information locally. When this occurs, the application is unable to properly function, which results in an Access Denied error message being displayed during network operations.

All Windows operating systems in the NT family that act as database servers for data files (meaning that data files are stored there and accessed by other Windows PCs) may need to have opportunistic locking disabled in order to minimize the risk of data file corruption. This includes Windows 9x/Me, Windows NT, Windows 200x and Windows XP.

If you are using a Windows NT family workstation in place of a server, you must also disable opportunistic locking (oplocks) on that workstation. For example, if you use a PC with the Windows NT Workstation operating system instead of Windows NT Server, and you have data files located on it that are accessed from other Windows PCs, you may need to disable oplocks on that system.

The major difference is the location in the Windows registry where the values for disabling oplocks are entered. Instead of the LanManServer location, the LanMan-Workstation location may be used.

You can verify (or change or add, if necessary) this Registry value using the Windows Registry Editor. When you change this registry value, you will have to reboot the PC to ensure that the new setting goes into effect.

The location of the client registry entry for opportunistic locking has changed in Windows 2000 from the earlier location in Microsoft Windows NT.

NOTE

Windows 2000 will still respect the EnableOplocks registry value used to disable oplocks in earlier versions of Windows.

You can also deny the granting of opportunistic locks by changing the following registry entries:

```
HKEY_LOCAL_MACHINE\System\  
  CurrentControlSet\Services\MRXSmb\Parameters\  
  
  OplocksDisabled REG_DWORD 0 or 1  
  Default: 0 (not disabled)
```

NOTE

The OplocksDisabled registry value configures Windows clients to either request or not request opportunistic locks on a remote file. To disable oplocks, the value of OplocksDisabled must be set to 1.

```
HKEY_LOCAL_MACHINE\System\  
  CurrentControlSet\Services\LanmanServer\Parameters  
  
  EnableOplocks REG_DWORD 0 or 1  
  Default: 1 (Enabled by Default)  
  
  EnableOpLockForceClose REG_DWORD 0 or 1  
  Default: 0 (Disabled by Default)
```

NOTE

The EnableOplocks value configures Windows-based servers (including Workstations sharing files) to allow or deny opportunistic locks on local files.

To force closure of open oplocks on close or program exit `EnableOpLockForceClose` must be set to 1.

An illustration of how level II oplocks work:

- Station 1 opens the file, requesting oplock.
- Since no other station has the file open, the server grants station 1 exclusive oplock.
- Station 2 opens the file, requesting oplock.
- Since station 1 has not yet written to the file, the server asks station 1 to Break to Level II Oplock.
- Station 1 complies by flushing locally buffered lock information to the server.
- Station 1 informs the server that it has Broken to Level II Oplock (alternatively, station 1 could have closed the file).
- The server responds to station 2's open request, granting it level II oplock. Other stations can likewise open the file and obtain level II oplock.
- Station 2 (or any station that has the file open) sends a write request SMB. The server returns the write response.
- The server asks all stations that have the file open to Break to None, meaning no station holds any oplock on the file. Because the workstations can have no cached writes or locks at this point, they need not respond to the break-to-none advisory; all they need do is invalidate locally cached read-ahead data.

14.4.1. Workstation Service Entries

```
\HKEY_LOCAL_MACHINE\System\  
  CurrentControlSet\Services\LanmanWorkstation\Parameters
```

```
UseOpportunisticLocking  REG_DWORD  0 or 1  
Default: 1 (true)
```

Indicates whether the redirector should use opportunistic-locking (oplock) performance enhancement. This parameter should be disabled only to isolate problems.

14.4.2. Server Service Entries

```
\HKEY_LOCAL_MACHINE\System\  
  CurrentControlSet\Services\LanmanServer\Parameters
```

```
EnableOplocks  REG_DWORD  0 or 1  
Default: 1 (true)
```

Specifies whether the server allows clients to use oplocks on files. Oplocks are a significant performance enhancement, but have the potential to cause lost cached data on some networks, particularly wide-area networks.

```
MinLinkThroughput  REG_DWORD  0 to infinite bytes per second  
Default: 0
```

Specifies the minimum link throughput allowed by the server before it disables raw and opportunistic locks for this connection.

MaxLinkDelay REG_DWORD 0 to 100,000 seconds
Default: 60

Specifies the maximum time allowed for a link delay. If delays exceed this number, the server disables raw I/O and opportunistic locking for this connection.

OplockBreakWait REG_DWORD 10 to 180 seconds
Default: 35

Specifies the time that the server waits for a client to respond to an oplock break request. Smaller values can allow detection of crashed clients more quickly but can potentially cause loss of cached data.

14.5. Persistent Data Corruption

If you have applied all of the settings discussed in this paper but data corruption problems and other symptoms persist, here are some additional things to check out:

We have credible reports from developers that faulty network hardware, such as a single faulty network card, can cause symptoms similar to read caching and data corruption. If you see persistent data corruption even after repeated reindexing, you may have to rebuild the data files in question. This involves creating a new data file with the same definition as the file to be rebuilt and transferring the data from the old file to the new one. There are several known methods for doing this that can be found in our Knowledge Base.

14.6. Common Errors

In some sites locking problems surface as soon as a server is installed, in other sites locking problems may not surface for a long time. Almost without exception, when a locking problem does surface it will cause embarrassment and potential data corruption.

Over the past few years there have been a number of complaints on the samba mailing lists that have claimed that samba caused data corruption. Three causes have been identified so far:

- Incorrect configuration of opportunistic locking (incompatible with the application being used. This is a VERY common problem even where MS Windows NT4 or MS Windows 200x based servers were in use. It is imperative that the software application vendors' instructions for configuration of file locking should be followed. If in doubt, disable oplocks on both the server and the client. Disabling of all forms of file caching on the MS Windows client may be necessary also.
- Defective network cards, cables, or HUBs / Switched. This is generally a more prevalent factor with low cost networking hardware, though occasionally there have been problems with incompatibilities in more up market hardware also.
- There have been some random reports of samba log files being written over data files. This has been reported by very few sites (about 5 in the past 3 years) and all attempts to reproduce the problem have failed. The Samba-Team has been unable to catch this happening and thus has NOT been able to isolate any particular cause. Considering the millions of systems that use samba, for the sites that have been affected by this as well as for the Samba-Team this is

a frustrating and a vexing challenge. If you see this type of thing happening please create a bug report on <https://bugzilla.samba.org> without delay. Make sure that you give as much information as you possibly can to help isolate the cause and to allow reproduction of the problem (an essential step in problem isolation and correction).

14.6.1. locking.tdb error messages

```
> We are seeing lots of errors in the samba logs like:
>
>   tdb(/usr/local/samba_2.2.7/var/locks/locking.tdb): rec_read bad magic
> 0x4d6f4b61 at offset=36116
>
> What do these mean?
```

Corrupted tdb. Stop all instances of `smbd`, delete `locking.tdb`, restart `smbd`.

14.7. Additional Reading

You may want to check for an updated version of this white paper on our Web site from time to time. Many of our white papers are updated as information changes. For those papers, the Last Edited date is always at the top of the paper.

Section of the Microsoft MSDN Library on opportunistic locking:

Opportunistic Locks, Microsoft Developer Network (MSDN), Windows Development > Windows Base Services > Files and I/O > SDK Documentation > File Storage > File Systems > About File Systems > Opportunistic Locks, Microsoft Corporation. http://msdn.microsoft.com/library/en-us/fileio/storage_5yk3.asp

Microsoft Knowledge Base Article Q224992 "Maintaining Transactional Integrity with OPLOCKS", Microsoft Corporation, April 1999, <http://support.microsoft.com/default.aspx?scid=kb;en-us;Q224992>.

Microsoft Knowledge Base Article Q296264 "Configuring Opportunistic Locking in Windows 2000", Microsoft Corporation, April 2001, <http://support.microsoft.com/default.aspx?scid=kb;en-us;Q296264>.

Microsoft Knowledge Base Article Q129202 "PC Ext: Explanation of Opportunistic Locking on Windows NT", Microsoft Corporation, April 1995, <http://support.microsoft.com/default.aspx?scid=kb;en-us;Q129202>.

15. Securing Samba

15.1. Introduction

This note was attached to the Samba 2.2.8 release notes as it contained an important security fix. The information contained here applies to Samba installations in general.

A new apprentice reported for duty to the Chief Engineer of a boiler house. He said, "Here I am, if you will show me the boiler I'll start working on it." Then engineer replied, "You're leaning on it!"

Security concerns are just like that: You need to know a little about the subject to appreciate how obvious most of it really is. The challenge for most of us is to discover that first morsel of knowledge with which we may unlock the secrets of the masters.

15.2. Features and Benefits

There are three level at which security principals must be observed in order to render a site at least moderately secure. These are: the perimeter firewall, the configuration of the host server that is running Samba, and Samba itself.

Samba permits a most flexible approach to network security. As far as possible Samba implements the latest protocols to permit more secure MS Windows file and print operations.

Samba may be secured from connections that originate from outside the local network. This may be done using *host based protection* (using samba's implementation of a technology known as "tcpwrappers", or it may be done be using *interface based exclusion* so that smbd will bind only to specifically permitted interfaces. It is also possible to set specific share or resource based exclusions, eg: on the IPC\$ auto-share. The IPC\$ share is used for browsing purposes as well as to establish TCP/IP connections.

Another method by which Samba may be secured is by way of setting Access Control Entries in an Access Control List on the shares themselves. This is discussed in the chapter on File, Directory and Share Access Control.

15.3. Technical Discussion of Protective Measures and Issues

The key challenge of security is the fact that protective measures suffice at best only to close the door on known exploits and breach techniques. Never assume that because you have followed these few measures that the Samba server is now an impenetrable fortress! Given the history of information systems so far, it is only a matter of time before someone will find yet another vulnerability.

15.3.1. Using host based protection

In many installations of Samba the greatest threat comes for outside your immediate network. By default Samba will accept connections from any host, which means that

if you run an insecure version of Samba on a host that is directly connected to the Internet you can be especially vulnerable.

One of the simplest fixes in this case is to use the `hosts allow` and `hosts deny` options in the Samba `smb.conf` configuration file to only allow access to your server from a specific range of hosts. An example might be:

```
hosts allow = 127.0.0.1 192.168.2.0/24 192.168.3.0/24
hosts deny = 0.0.0.0/0
```

The above will only allow SMB connections from 'localhost' (your own computer) and from the two private networks 192.168.2 and 192.168.3. All other connections will be refused as soon as the client sends its first packet. The refusal will be marked as a not listening on called name error.

15.3.2. User based protection

If you want to restrict access to your server to valid users only then the following method may be of use. In the `smb.conf` [globals] section put:

```
valid users = @smbusers, jacko
```

What this does is, it restricts all server access to either the user *jacko* or to members of the system group *smbusers*.

15.3.3. Using interface protection

By default Samba will accept connections on any network interface that it finds on your system. That means if you have a ISDN line or a PPP connection to the Internet then Samba will accept connections on those links. This may not be what you want.

You can change this behaviour using options like the following:

```
interfaces = eth* lo
bind interfaces only = yes
```

This tells Samba to only listen for connections on interfaces with a name starting with 'eth' such as eth0, eth1, plus on the loopback interface called 'lo'. The name you will need to use depends on what OS you are using, in the above I used the common name for Ethernet adapters on Linux.

If you use the above and someone tries to make a SMB connection to your host over a PPP interface called 'ppp0' then they will get a TCP connection refused reply. In that case no Samba code is run at all as the operating system has been told not to pass connections from that interface to any samba process.

15.3.4. Using a firewall

Many people use a firewall to deny access to services that they don't want exposed outside their network. This can be a very good idea, although I would recommend using it in conjunction with the above methods so that you are protected even if your firewall is not active for some reason.

If you are setting up a firewall then you need to know what TCP and UDP ports to allow and block. Samba uses the following:

UDP/137 - used by nmbd
UDP/138 - used by nmbd
TCP/139 - used by smb
TCP/445 - used by smb

The last one is important as many older firewall setups may not be aware of it, given that this port was only added to the protocol in recent years.

15.3.5. Using a IPC\$ share deny

If the above methods are not suitable, then you could also place a more specific deny on the IPC\$ share that is used in the recently discovered security hole. This allows you to offer access to other shares while denying access to IPC\$ from potentially untrustworthy hosts.

To do that you could use:

```
[ipc$]
hosts allow = 192.168.115.0/24 127.0.0.1
hosts deny = 0.0.0.0/0
```

this would tell Samba that IPC\$ connections are not allowed from anywhere but the two listed places (localhost and a local subnet). Connections to other shares would still be allowed. As the IPC\$ share is the only share that is always accessible anonymously this provides some level of protection against attackers that do not know a username/password for your host.

If you use this method then clients will be given a access denied reply when they try to access the IPC\$ share. That means that those clients will not be able to browse shares, and may also be unable to access some other resources.

This is not recommended unless you cannot use one of the other methods listed above for some reason.

15.3.6. NTLMv2 Security

To configure NTLMv2 authentication the following registry keys are worth knowing about:

```
[HKEY_LOCAL_MACHINE\SYSTEM\CurrentControlSet\Control\Lsa]
"lmcompatibilitylevel"=dword:00000003
```

0x3 - Send NTLMv2 response only. Clients will use NTLMv2 authentication, use NTLMv2 session security if the server supports it. Domain controllers accept LM, NTLM and NTLMv2 authentication.

```
[HKEY_LOCAL_MACHINE\SYSTEM\CurrentControlSet\Control\Lsa\MSV1_0]
"NtlmMinClientSec"=dword:00080000
```

0x80000 - NTLMv2 session security. If either NtlmMinClientSec or NtlmMinServerSec is set to 0x80000, the connection will fail if NTLMv2 session security is not negotiated.

15.4. Upgrading Samba

Please check regularly on <http://www.samba.org/> for updates and important announcements. Occasionally security releases are made and it is highly recommended to upgrade Samba when a security vulnerability is discovered.

15.5. Common Errors

If all of samba and host platform configuration were really as intuitive as one might like then this section would not be necessary. Security issues are often vexing for a support person to resolve, not because of the complexity of the problem, but for reason that most administrators who post what turns out to be a security problem request are totally convinced that the problem is with Samba.

15.5.1. Smbclient works on localhost, but the network is dead

This is a very common problem. Red Hat Linux (as do others) will install a default firewall. With the default firewall in place only traffic on the loopback adapter (IP address 127.0.0.1) will be allowed through the firewall.

The solution is either to remove the firewall (stop it) or to modify the firewall script to allow SMB networking traffic through. See section above in this chapter.

15.5.2. Why can users access home directories of other users?

‘We are unable to keep individual users from mapping to any other user’s home directory once they have supplied a valid password! They only need to enter their own password. I have not found **any** method that I can use to configure samba to enforce that only a user may map their own home directory.’

‘User xyzyzy can map his home directory. Once mapped user xyzyzy can also map **anyone** else’s home directory!’

This is not a security flaw, it is by design. Samba allows users to have **exactly** the same access to the UNIX filesystem as they would if they were logged onto the UNIX box, except that it only allows such views onto the file system as are allowed by the defined shares.

This means that if your UNIX home directories are set up such that one user can happily `cd` into another user’s directory and do an `ls`, the UNIX security solution is to change the UNIX file permissions on the user’s home directories such that the `cd` and `ls` would be denied.

Samba tries very hard not to second guess the UNIX administrator’s security policies, and trusts the UNIX admin to set the policies and permissions he or she desires.

Samba does allow the setup you require when you have set the only `user = yes` option on the share, is that you have not set the `valid users` list for the share.

Note that only `user` works in conjunction with the `users=` list, so to get the behavior you require, add the line :

```
users = %S
```

this is equivalent to:

```
valid users = %S
```

to the definition of the `[homes]` share, as recommended in the `smb.conf` man page.

16. Interdomain Trust Relationships

Samba-3 supports NT4 style domain trust relationships. This is feature that many sites will want to use if they migrate to Samba-3 from and NT4 style domain and do NOT want to adopt Active Directory or an LDAP based authentication back end. This section explains some background information regarding trust relationships and how to create them. It is now possible for Samba-3 to NT4 trust (and vice versa), as well as Samba3 to Samba3 trusts.

16.1. Features and Benefits

Samba-3 can participate in Samba-to-Samba as well as in Samba-to-MS Windows NT4 style trust relationships. This imparts to Samba similar scalability as is possible with MS Windows NT4.

Given that Samba-3 has the capability to function with a scalable backend authentication database such as LDAP, and given it's ability to run in Primary as well as Backup Domain control modes, the administrator would be well advised to consider alternatives to the use of Interdomain trusts simplt because by the very nature of how this works it is fragile. That was after all a key reason for the development and adoption of Microsoft Active Directory.

16.2. Trust Relationship Background

MS Windows NT3.x/4.0 type security domains employ a non-hierarchical security structure. The limitations of this architecture as it affects the scalability of MS Windows networking in large organisations is well known. Additionally, the flat-name space that results from this design significantly impacts the delegation of administrative responsibilities in large and diverse organisations.

Microsoft developed Active Directory Service (ADS), based on Kerberos and LDAP, as a means of circumventing the limitations of the older technologies. Not every organisation is ready or willing to embrace ADS. For small companies the older NT4 style domain security paradigm is quite adequate, there thus remains an entrenched user base for whom there is no direct desire to go through a disruptive change to adopt ADS.

Microsoft introduced with MS Windows NT the ability to allow differing security domains to affect a mechanism so that users from one domain may be given access rights and privileges in another domain. The language that describes this capability is couched in terms of *Trusts*. Specifically, one domain will *trust* the users from another domain. The domain from which users are available to another security domain is said to be a trusted domain. The domain in which those users have assigned rights and privileges is the trusting domain. With NT3.x/4.0 all trust relationships are always in one direction only, thus if users in both domains are to have privileges and rights in each others' domain, then it is necessary to establish two (2) relationships, one in each direction.

In an NT4 style MS security domain, all trusts are non-transitive. This means that if there are three (3) domains (let's call them RED, WHITE, and BLUE) where RED and WHITE have a trust relationship, and WHITE and BLUE have a trust

relationship, then it holds that there is no implied trust between the RED and BLUE domains. ie: Relationships are explicit and not transitive.

New to MS Windows 2000 ADS security contexts is the fact that trust relationships are two-way by default. Also, all inter-ADS domain trusts are transitive. In the case of the RED, WHITE and BLUE domains above, with Windows 2000 and ADS the RED and BLUE domains CAN trust each other. This is an inherent feature of ADS domains. Samba-3 implements MS Windows NT4 style Interdomain trusts and interoperates with MS Windows 200x ADS security domains in similar manner to MS Windows NT4 style domains.

16.3. Native MS Windows NT4 Trusts Configuration

There are two steps to creating an interdomain trust relationship.

16.3.1. NT4 as the Trusting Domain (ie. creating the trusted account)

For MS Windows NT4, all domain trust relationships are configured using the Domain User Manager. To affect a two way trust relationship it is necessary for each domain administrator to make available (for use by an external domain) it's security resources. This is done from the Domain User Manager Policies entry on the menu bar. From the **Policy** menu, select **Trust Relationships**, then next to the lower box that is labelled **Permitted to Trust this Domain** are two buttons, **Add** and **Remove**. The **Add** button will open a panel in which needs to be entered the remote domain that will be able to assign user rights to your domain. In addition it is necessary to enter a password that is specific to this trust relationship. The password needs to be typed twice (for standard confirmation).

16.3.2. NT4 as the Trusted Domain (ie. creating trusted account's password)

A trust relationship will work only when the other (trusting) domain makes the appropriate connections with the trusted domain. To consummate the trust relationship the administrator will launch the Domain User Manager, from the menu select Policies, then select Trust Relationships, then click on the **Add** button that is next to the box that is labelled **Trusted Domains**. A panel will open in which must be entered the name of the remote domain as well as the password assigned to that trust.

16.4. Configuring Samba NT-style Domain Trusts

This description is meant to be a fairly short introduction about how to set up a Samba server so that it could participate in interdomain trust relationships. Trust relationship support in Samba is in its early stage, so lot of things don't work yet.

Each of the procedures described below is treated as they were performed with Windows NT4 Server on one end. The remote end could just as well be another Samba-3 domain. It can be clearly seen, after reading this document, that combining Samba-specific parts of what's written below leads to trust between domains in purely Samba environment.

16.4.1. Samba-3 as the Trusting Domain

In order to set the Samba PDC to be the trusted party of the relationship first you need to create special account for the domain that will be the trusting party. To do that, you can use the 'smbpasswd' utility. Creating the trusted domain account is

very similar to creating a trusted machine account. Suppose, your domain is called SAMBA, and the remote domain is called RUMBA. The first step will be to issue this command from your favourite shell:

```
root# smbpasswd -a -i rumba
New SMB password: XXXXXXXX
Retype SMB password: XXXXXXXX
Added user rumba$
```

where `-a` means to add a new account into the `passwd` database and `-i` means: "create this account with the InterDomain trust flag"

The account name will be `'rumba$'` (the name of the remote domain)

After issuing this command you'll be asked to enter the password for the account. You can use any password you want, but be aware that Windows NT will not change this password until 7 days following account creation. After the command returns successfully, you can look at the entry for the new account (in the standard way depending on your configuration) and see that account's name is really `RUMBA$` and it has 'I' flag in the flags field. Now you're ready to confirm the trust by establishing it from Windows NT Server.

Open User Manager for Domains and from menu **Policies** select **Trust Relationships...** Right beside **Trusted domains** list box press the **Add...** button. You will be prompted for the trusted domain name and the relationship password. Type in SAMBA, as this is your domain name, and the password used at the time of account creation. Press OK and, if everything went without incident, you will see **Trusted domain relationship successfully established** message.

16.4.2. Samba-3 as the Trusted Domain

This time activities are somewhat reversed. Again, we'll assume that your domain controlled by the Samba PDC is called SAMBA and NT-controlled domain is called RUMBA.

The very first thing requirement is to add an account for the SAMBA domain on RUMBA's PDC.

Launch the Domain User Manager, then from the menu select **Policies, Trust Relationships**. Now, next to **Trusted Domains** box press the **Add** button, and type in the name of the trusted domain (SAMBA) and password securing the relationship.

The password can be arbitrarily chosen. It is easy to change the password from the Samba server whenever you want. After confirming the password your account is ready for use. Now it's Samba's turn.

Using your favourite shell while being logged in as root, issue this command:

```
root#net rpc trustdom establish rumba
```

You will be prompted for the password you just typed on your Windows NT4 Server box. Do not worry if you see an error message that mentions a returned code of `NT_STATUS_NOLOGON_INTERDOMAIN_TRUST_ACCOUNT`. It means the password you gave is correct and the NT4 Server says the account is ready for interdomain connection and not for ordinary connection. After that, be patient it can take a while (especially in large networks), you should see the **Success** message. Congratulations! Your trust relationship has just been established.

NOTE



Note that you have to run this command as root because you must have write access to the `secrets.tdb` file.

16.5. Common Errors

Interdomain trust relationships should NOT be attempted on networks that are unstable or that suffer regular outages. Network stability and integrity are key concerns with distributed trusted domains.

16.5.1. Tell me about Trust Relationships using Samba

Like many, I administer multiple LANs connected together using NT trust relationships. This was implemented about 4 years ago. I now have the occasion to consider performing this same task again, but this time, I would like to implement it solely through samba - no Microsoft PDCs anywhere.

I have read documentation on samba.org regarding NT-style trust relationships and am now wondering, can I do what I want to? I already have successfully implemented 2 samba servers, but they are not PDCs. They merely act as file servers. I seem to remember, and it appears to be true (according to samba.org) that trust relationships are a challenge.

Please provide any helpful feedback that you may have.

These are almost complete in Samba 3.0 snapshots. The main catch is getting `winbindd` to be able to allocate `uid/gid`'s for trusted users/groups. See the updated Samba HOWTO collection for more details.

17. Hosting a Microsoft Distributed File System tree on Samba

17.1. Features and Benefits

The Distributed File System (or DFS) provides a means of separating the logical view of files and directories that users see from the actual physical locations of these resources on the network. It allows for higher availability, smoother storage expansion, load balancing etc.

For information about DFS, refer to [Microsoft documentation at http://www.microsoft.com/NTServ](http://www.microsoft.com/NTServ)

This document explains how to host a DFS tree on a Unix machine (for DFS-aware clients to browse) using Samba.

To enable SMB-based DFS for Samba, configure it with the `-with-msdfs` option. Once built, a Samba server can be made a DFS server by setting the global boolean `host msdfs` parameter in the `smb.conf` file. You designate a share as a DFS root using the share level boolean `msdfs root` parameter. A DFS root directory on Samba hosts DFS links in the form of symbolic links that point to other servers. For example, a symbolic link `junction->msdfs:storage1\share1` in the share directory acts as the DFS junction. When DFS-aware clients attempt to access the junction link, they are redirected to the storage location (in this case, `\\storage1\share1`).

DFS trees on Samba work with all DFS-aware clients ranging from Windows 95 to 200x.

Here's an example of setting up a DFS tree on a Samba server.

```
# The smb.conf file:
[global]
    netbios name = SMOKEY
    host msdfs    = yes

[dfs]
    path = /export/dfsroot
    msdfs root = yes
```

In the `/export/dfsroot` directory we set up our dfs links to other servers on the network.

```
root# cd /export/dfsroot
root# chown root /export/dfsroot
root# chmod 755 /export/dfsroot
root# ln -s msdfs:storageA\\shareA linka
root# ln -s msdfs:serverB\\share,serverC\\share linkb
```

You should set up the permissions and ownership of the directory acting as the DFS root such that only designated users can create, delete or modify the msdfs links. Also note that symlink names should be all lowercase. This limitation exists

to have Samba avoid trying all the case combinations to get at the link name. Finally set up the symbolic links to point to the network shares you want, and start Samba.

Users on DFS-aware clients can now browse the DFS tree on the Samba server at `\\samba\dfs`. Accessing links `linka` or `linkb` (which appear as directories to the client) takes users directly to the appropriate shares on the network.

17.2. Common Errors

- Windows clients need to be rebooted if a previously mounted non-dfs share is made a dfs root or vice versa. A better way is to introduce a new share and make it the dfs root.
- Currently there's a restriction that msdfs symlink names should all be lower-case.
- For security purposes, the directory acting as the root of the DFS tree should have ownership and permissions set so that only designated users can modify the symbolic links in the directory.

18. Classical Printing Support

18.1. Features and Benefits

Printing is often a mission-critical service for the users. Samba can provide this service reliably and seamlessly for a client network consisting of Windows workstations.

A Samba-3.0 print service may be run on a Standalone or a Domain member server, side by side with file serving functions, or on a dedicated print server. It can be made as tight or as loosely secured as needs dictate. Configurations may be simple or complex. Available authentication schemes are essentially the same as described for file services in previous chapters. Overall, Samba's printing support is now able to replace an NT or Windows 2000 print server full-square, with additional benefits in many cases. Clients may download and install drivers and printers through their familiar "Point'n'Print" mechanism. Printer installations executed by "Logon Scripts" are no problem. Administrators can upload and manage drivers to be used by clients through the familiar "Add Printer Wizard". As an additional benefit, driver and printer management may be run from the commandline or through scripts, making it more efficient in case of large numbers of printers. If a central accounting of print jobs (tracking every single page and supplying the raw data for all sorts of statistical reports) is required, this is best supported by CUPS as the print subsystem underneath the Samba hood.

This chapter deals with the foundations of Samba printing, as they implemented by the more traditional UNIX (BSD- and System V-style) printing systems. Many things apply to CUPS, the newer Common UNIX Printing System, too; so if you use CUPS, you might be tempted to jump to the next chapter – but you will certainly miss a few things if you do so. Better read this chapter too.

NOTE



Most of the given examples have been verified on Windows XP Professional clients. Where this document describes the responses to commands given, bear in mind that Windows 2000 clients are very similar, but may differ in details. Windows NT is somewhat different again.

18.2. Technical Introduction

Samba's printing support always relies on the installed print subsystem of the Unix OS it runs on. Samba is a "middleman". It takes printfiles from Windows (or other SMB) clients and passes them to the real printing system for further processing. Therefore it needs to "talk" to two sides: to the Windows print clients and to the Unix printing system. Hence we must differentiate between the various client OS types each of which behave differently, as well as the various UNIX print subsystems, which themselves have different features and are accessed differently. This part of the Samba HOWTO Collection deals with the "traditional" way of Unix printing first;

the next chapter covers in great detail the more modern *Common UNIX Printing System* (CUPS).

IMPORTANT

CUPS users, be warned: don't just jump on to the next chapter. You might miss important information contained only here!

18.2.1. What happens if you send a Job from a Client

To successfully print a job from a Windows client via a Samba print server to a UNIX printer, there are 6 (potentially 7) stages:

1. Windows opens a connection to the printershare
2. Samba must authenticate the user
3. Windows sends a copy of the printfile over the network into Samba's spooling area
4. Windows closes the connection again
5. Samba invokes the print command to hand the file over to the UNIX print subsystem's spooling area
6. The Unix print subsystem processes the print job
7. The printfile may need to be explicitly deleted from the Samba spooling area.

18.2.2. Printing Related Configuration Parameters

There are a number of configuration parameters in controlling Samba's printing behaviour. Please also refer to the man page for `smb.conf` to acquire an overview about these. As with other parameters, there are Global Level (tagged with a "G" in the listings) and Service Level ("S") parameters.

Service Level Parameters These *may* go into the [global] section of `.`. In this case they define the default behaviour of all individual or service level shares (provided those don't have a different setting defined for the same parameter, thus overriding the global default).

Global Parameters These *may not* go into individual shares. If they go in by error, the "testparm" utility can discover this (if you run it) and tell you so.

18.2.3. Parameters Recommended for Use

The following `smb.conf` parameters directly related to printing are used in Samba-3. See also the `smb.conf` man page for detailed explanations:

List of printing related parameters in Samba-3

GLOBAL LEVEL PARAMETERS:

- `addprinter command` (G)
- `deleteprinter command` (G)
- `disable spoolss` (G)
- `enumports command` (G)
- `load printers` (G)
- `lpq cache time` (G)
- `os2 driver map` (G)
- `printcap name` (G), `printcap` (G)
- `show add printer wizard` (G)

- total print jobs (G)
- use client driver (G)

SERVICE LEVEL PARAMETERS:

- hosts allow (S)
- hosts deny (S)
- lppause command (S)
- lpq command (S)
- lpresume command (S)
- lprm command (S)
- max print jobs (S)
- min print space (S)
- print command (S)
- printable (S), print ok (S)
- printer name (S), printer (S)
- printer admin (S)
- printing = [cups—bsd—lprng...] (S)
- queuepause command (S)
- queueresume command (S)
- total print jobs (S)

Samba's printing support implements the Microsoft Remote Procedure Calls (MS-RPC) methods for printing. These are used by Windows NT (and later) print servers. The old "LanMan" protocol is still supported as a fallback resort, and for older clients to use. More details will follow further beneath.

18.2.4. Parameters for Backwards Compatibility

Two new parameters that were added in Samba 2.2.2, are still present in Samba-3.0. Both of these options are described in the `smb.conf` man page and are disabled by default. *Use them with caution!*

disable spoolss(G) This is provided for better support of Samba 2.0.x backwards capability. It will disable Samba's support for MS-RPC printing and yield identical printing behaviour to Samba 2.0.x.

use client driver (G) was provided for using local printer drivers on Windows NT/2000 clients. It does not apply to Windows 95/98/ME clients.

Parameters "for backward compatibility only", use with caution

- disable spoolss (G)
- use client driver (S)

18.2.5. Parameters no longer in use

Samba users upgrading from 2.2.x to 3.0 need to be aware that some previously available settings are no longer supported (as was announced some time ago). Here is a list of them:

"old" parameters, removed in Samba-3 The following `smb.conf` parameters have been deprecated already in Samba 2.2 and are now completely removed from Samba-3. You cannot use them in new 3.0 installations:

- printer driver file (G)
- total print jobs (G)
- postscript (S)
- printer driver (S)
- printer driver location (S)

18.3. A simple Configuration to Print with Samba-3

Here is a very simple example configuration for print related settings in the file. If you compare it with your own system's , you probably find some additional parameters included there (as pre-configured by your OS vendor). Further below is a discussion and explanation of the parameters. Note, that this example doesn't use many parameters. However, in many environments these are enough to provide a valid which enables all clients to print.

```
[global]
    printing = bsd
    load printers = yes

[printers]
    path = /var/spool/samba
    printable = yes
    public = yes
    writable = no
```

This is only an example configuration. Many settings, if not explicitly set to a specific value, are used and set by Samba implicitly to its own default, because these have been compiled in. To see all settings, let root use the **testparm** utility. **testparm** also gives warnings if you have mis-configured certain things. Its complete output is easily 340 lines and more. You may want to pipe it through a pager program.

The syntax for the configuration file is easy to grasp. You should know that is not very picky about its syntax. It has been explained elsewhere in this document. A short reminder: It even tolerates some spelling errors (like "browsable" instead of "browseable"). Most spelling is case-insensitive. Also, you can use "Yes—No" or "True—False" for boolean settings. Lists of names may be separated by commas, spaces or tabs.

18.3.1. Verification of "Settings in Use" with testparm

To see all (or at least most) printing related settings in Samba, including the implicitly used ones, try the command outlined below (hit "ENTER" twice!). It greps for all occurrences of "lp", "print", "spool", "driver", "ports" and "[" in testparm's output and gives you a nice overview about the running smbd's print configuration. (Note that this command does not show individually created printer shares, or the spooling paths in each case). Here is the output of my Samba setup, with exactly the same settings in as shown above:

```
root# testparm -v | egrep "(lp|print|spool|driver|ports|\\[)"
Load smb config files from /etc/samba/smb.conf.simpleprinting
Processing section "[homes]"
Processing section "[printers]"

[global]
    smb ports = 445 139
    lpq cache time = 10
    total print jobs = 0
    load printers = Yes
```

```
printcap name = /etc/printcap
disable spoolss = No
enumports command =
addprinter command =
deleteprinter command =
show add printer wizard = Yes
os2 driver map =
printer admin =
min print space = 0
max print jobs = 1000
printable = No
printing = bsd
print command = lpr -r -P'%p' %s
lpq command = lpq -P'%p'
lprm command = lprm -P'%p' %j
lppause command =
lpresume command =
printer name =
use client driver = No
```

```
[homes]
```

```
[printers]
```

```
path = /var/spool/samba
printable = Yes
```

You can easily verify which settings were implicitly added by Samba's default behaviour. *Don't forget about this point: it may be important in your future dealings with Samba.*

NOTE

testparm in Samba-3.0 behaves differently from 2.2.x: used without the "-v" switch it only shows you the settings actually written into ! To see the complete configuration used, add the "-v" parameter to testparm.

18.3.2. A little Experiment to warn you

Should you need to troubleshoot at any stage, please always come back to this point first and verify if "testparm" shows the parameters you expect! To give you an example from personal experience as a warning, try to just "comment out" the load printers" parameter. If your 2.2.x system behaves like mine, you'll see this:

```
root# grep "load printers" /etc/samba/smb.conf
# load printers = Yes
# This setting is commented ooouuuut!!
```

```
root# testparm -v /etc/samba/smb.conf | egrep "(load printers)"
```

```
load printers = Yes
```

Despite my imagination that the commenting out of this setting should prevent Samba from publishing my printers, it still did! Oh Boy – it cost me quite some time to find out the reason. But I am not fooled any more... at least not by this ;-)

```
root# grep -A1 "load printers" /etc/samba/smb.conf
load printers = No
# This setting is what I mean!!
# load printers = Yes
# This setting is commented ooooouuut!!
```

```
root# testparm -v smb.conf.simpleprinting | egrep "(load printers)"
load printers = No
```

Only when setting the parameter explicitly to "load printers = No" would Samba recognize my intentions. So my strong advice is:

- Never rely on "commented out" parameters!
- Always set it up explicitly as you intend it to behave.
- Use **testparm** to uncover hidden settings which might not reflect your intentions.

You can have a working Samba print configuration with this minimal :

```
root# cat /etc/samba/smb.conf-minimal
[printers]
```

This example should show you that you can use testparm to test any filename for fitness as a Samba configuration. Actually, we want to encourage you *not* to change your on a working system (unless you know exactly what you are doing)! Don't rely on an assumption that changes will only take effect after you re-start smbd! This is not the case. Samba re-reads its every 60 seconds and on each new client connection. You might have to face changes for your production clients that you didn't intend to apply at this time! You will now note a few more interesting things. Let's now ask **testparm** what the Samba print configuration would be, if you used this minimalistic file as your real :

```
root# testparm -v /etc/samba/smb.conf-minimal | egrep "(print|lpq|spool|driver|port)
Processing section "[printers]"
WARNING: [printers] service MUST be printable!
No path in service printers - using /tmp

lpq cache time = 10
total print jobs = 0
load printers = Yes
printcap name = /etc/printcap
disable spoolss = No
enumports command =
addprinter command =
```

```
deleteprinter command =
show add printer wizard = Yes
os2 driver map =
printer admin =
min print space = 0
max print jobs = 1000
printable = No
printing = bsd
print command = lpr -r -P%p %s
lpq command = lpq -P%p
printer name =
use client driver = No
[printers]
printable = Yes
```

testparm issued 2 warnings:

- because we didn't specify the [printers] section as printable, and
- because we didn't tell it which spool directory to use.

However, this was not fatal, and Samba-3.0 will default to values that will work here. But, please!, don't rely on this and don't use this example! This was only meant to make you careful to design and specify your setup to be what you really want it to be. The outcome on your system may vary for some parameters, since you may have a Samba built with a different compile-time configuration. *Warning:* don't put a comment sign *at the end* of a valid line. It will cause the parameter to be ignored (just as if you had put the comment sign at the front). At first I regarded this as a bug in my Samba version(s). But the man page states: 'Internal whitespace in a parameter value is retained verbatim.' This means that a line consisting of, for example,

```
printing =lprng      #This defines LPRng as the printing system"
```

will regard the whole of the string after the "=" sign as the value you want to define. And this is an invalid value that will be ignored, and a default value used instead.]

18.4. Extended Sample Configuration to Print with Samba-3

Here we show a more verbose example configuration for print related settings in an . Below is a discussion and explanation of the various parameters. We chose to use BSD-style printing here, because we guess it is still the most commonly used system on legacy Linux installations (new installs now predominantly have CUPS, which is discussed entirely in the next chapter of this document). Note, that this example explicitly names many parameters which don't need to be stated because they are set by default. You might be able to do with a leaner .

TIP



if you read access it with the Samba Web Administration Tool (SWAT), and then write it to disk again, it will be optimized in a way such that it doesn't contain any superfluous parameters and comments. SWAT organizes the file for best performance. Remember that each `smbd` re-reads the Samba configuration once a minute, and that each connection spawns an `smbd` process of its own, so it is not a bad idea to optimize the in environments with hundreds or thousands of clients.

```
[global]
    printing = bsd
    load printers = yes
    show add printer wizard = yes
    printcap name = /etc/printcap
    printer admin = @ntadmin, root
    total print jobs = 100
    lpq cache time = 20
    use client driver = no

[printers]
    comment = All Printers
    printable = yes
    path = /var/spool/samba
    browseable = no
    guest ok = yes
    public = yes
    read only = yes
    writable = no

[my_printer_name]
    comment = Printer with Restricted Access
    path = /var/spool/samba_my_printer
    printer admin = kurt
    browseable = yes
    printable = yes
    writeable = no
    hosts allow = 0.0.0.0
    hosts deny = turbo_xp, 10.160.50.23, 10.160.51.60
    guest ok = no
```

This *also* is only an example configuration. You may not find all the settings in your own (as pre-configured by your OS vendor). Many configuration parameters, if not explicitly set to a specific value, are used and set by Samba implicitly to its own default, because these have been compiled in. To see all settings, let root use the **testparm** utility. **testparm** also gives warnings if you have mis-configured certain things..

18.5. Detailed Explanation of the Example's Settings

Following is a discussion of the settings from above shown example.

18.5.1. The [global] Section

The [global] section is one of 4 special sections (along with [[homes], [printers] and [print\$]...). It contains all parameters which apply to the server as a whole. It is the place for parameters which have only a "global" meaning (G). It may also contain service level parameters (S) which then define default settings for all other sections and shares. This way you can simplify the configuration and avoid setting the same value repeatedly. (Within each individual section or share you may however override these globally set "share level" settings and specify other values).

printing = bsd this causes Samba to use default print commands applicable for the BSD (a.k.a. RFC 1179 style or LPR/LPD) printing system. In general, the "printing" parameter informs Samba about the print subsystem it should expect. Samba supports CUPS, LPD, LPRNG, SYSV, HPUX, AIX, QNX and PLP. Each of these systems defaults to a different print command (and other queue control commands).

CAUTION



The printing parameter is normally a service level parameter. Since it is included here in the [global] section, it will take effect for all printer shares that are not defined differently. Samba-3.0 no longer supports the SOFTQ printing system.

load printers = yes this tells Samba to create automatically all available printer shares. "Available" printer shares are discovered by scanning the printcap file. All created printer shares are also loaded for browsing. If you use this parameter, you do not need to specify separate shares for each printer. Each automatically created printer share will clone the configuration options found in the [printers] section. (A load printers = no setting will allow you to specify each UNIX printer you want to share separately, leaving out some you don't want to be publicly visible and available).

show add printer wizard = yes this setting is normally enabled by default (even if the parameter is not written into the). It makes the **Add Printer Wizard** icon show up in the **Printers** folder of the Samba host's share listing (as shown in **Network Neighbourhood** or by the **net view** command). To disable it, you need to explicitly set it to **no** (commenting it out will not suffice!). The Add Printer Wizard lets you upload printer drivers to the [print\$] share and associate it with a printer (if the respective queue exists there before the action), or exchange a printer's driver against any other previously uploaded driver.

total print jobs = 100 this setting sets the upper limit to 100 print jobs being active on the Samba server at any one time. Should a client submit a job which exceeds this number, a 'no more space available on server' type of error message will be returned by Samba to the client. A setting of "0" (the default) means there is *no* limit at all!

printcap name = /etc/printcap this tells Samba where to look for a list of available printer names. (If you use CUPS, make sure that a printcap file is written:

this is controlled by the "Printcap" directive of `cupsd.conf`).

printer admin = @ntadmin members of the `ntadmin` group should be able to add drivers and set printer properties ("ntadmin" is only an example name, it needs to be a valid UNIX group name); root is implicitly always a printer admin. The "@" sign precedes group names in `.`. A printer admin can do anything to printers via the remote administration interfaces offered by MS-RPC (see below). Note that the printer admin parameter is normally a share level parameter, so you may associate different groups to different printer shares in larger installations, if you use the printer admin parameter on the share levels).

lpq cache time = 20 this controls the cache time for the results of the `lpq` command. It prevents the `lpq` command being called too often and reduces load on a heavily used print server.

use client driver = no if set to `yes`, this setting only takes effect for Win NT/2k/XP clients (and not for Win 95/98/ME). Its default value is `No` (or `False`). It must *not* be enabled on print shares (with a `yes` or `true` setting) which have valid drivers installed on the Samba server! For more detailed explanations see the man page of `smb.conf`.

18.5.2. The [printers] Section

This is the second special section. If a section with this name appears in the `smb.conf`, users are able to connect to any printer specified in the Samba host's `printcap` file, because Samba on startup then creates a printer share for every printername it finds in the `printcap` file. You could regard this section as a general convenience shortcut to share all printers with minimal configuration. It is also a container for settings which should apply as default to all printers. (For more details see the `smb.conf` man page.) Settings inside this container must be share level parameters (S).

comment = All printers the comment is shown next to the share if a client queries the server, either via **Network Neighbourhood** or with the `net view` command to list available shares.

printable = yes please note well, that the [printers] service *must* be declared as printable. If you specify otherwise, `smbd` will refuse to load at startup. This parameter allows connected clients to open, write to and submit spool files into the directory specified with the `path` parameter for this service. It is used by Samba to differentiate printer shares from file shares.

path = /var/spool/samba this must point to a directory used by Samba to spool incoming print files. *It must not be the same as the spool directory specified in the configuration of your UNIX print subsystem!* The path would typically point to a directory which is world writeable, with the "sticky" bit set to it.

browseable = no this is always set to `no` if `printable = yes`. It makes the [printer] share itself invisible in the list of available shares in a `net view` command or in the Explorer browse list. (Note that you will of course see the individual printers).

guest ok = yes if set to `yes`, then no password is required to connect to the printers service. Access will be granted with the privileges of the guest account. On many systems the guest account will map to a user named "nobody". This user is in the UNIX `passwd` file with an empty password, but with no valid UNIX login. (Note: on some systems the guest account might not have the privilege to be able to print. Test this by logging in as your guest user using `su - guest` and run a system print command like

`lpr -P printername /etc/motd`

public = yes this is a synonym for `guest ok = yes`. Since we have `guest ok = yes`, it really doesn't need to be here! (This leads to the interesting question: 'What, if I by accident have to contradictory settings for the same share?' The answer is: the last one encountered by Samba wins. The "winner" is shown by `testparm`. `Testparm` doesn't complain about different settings of the same parameter for the same share! You can test this by setting up multiple lines for the "guest account" parameter with different usernames, and then run `testparm` to see which one is actually used by Samba.)

read only = yes this normally (for other types of shares) prevents users creating or modifying files in the service's directory. However, in a "printable" service, it is *always* allowed to write to the directory (if user privileges allow the connection), but only via print spooling operations. "Normal" write operations are not allowed.

writable = no synonym for `read only = yes`

18.5.3. Any [my_printer_name] Section

If a section appears in the `[my_printer_name]`, which is tagged as `printable = yes`, Samba presents it as a printer share to its clients. Note, that Win95/98/ME clients may have problems with connecting or loading printer drivers if the share name has more than 8 characters! Also be very careful if you give a printer the same name as an existing user or file share name: upon a client's connection request to a certain sharename, Samba always tries to find file shares with that name first; if it finds one, it will connect to this and will never ultimately connect to a printer with the same name!

comment = Printer with Restricted Access the comment says it all.

path = /var/spool/samba.my_printer here we set the spooling area for this printer to another directory than the default. It is not a requirement to set it differently, but the option is available.

printer admin = kurt the printer admin definition is different for this explicitly defined printer share from the general `[printers]` share. It is not a requirement; we did it to show that it is possible if you want it.

browseable = yes we also made this printer browseable (so that the clients may conveniently find it when browsing the **Network Neighbourhood**).

printable = yes see explanation in last subsection.

writable = no see explanation in last subsection.

hosts allow = 10.160.50.,10.160.51. here we exercise a certain degree of access control by using the `hosts allow` and `hosts deny` parameters. Note, that this is not by any means a safe bet. It is not a way to secure your printers. This line accepts all clients from a certain subnet in a first evaluation of access control

hosts deny = turbo_xp,10.160.50.23,10.160.51.60 all listed hosts are not allowed here (even if they belong to the "allowed subnets"). As you can see, you could name IP addresses as well as NetBIOS hostnames here.

guest ok = no this printer is not open for the guest account!

18.5.4. Print Commands

In each section defining a printer (or in the `[printers]` section), a `print` command parameter may be defined. It sets a command to process the files which have been placed into the Samba print spool directory for that printer. (That spool directory was, if you remember, set up with the `path` parameter). Typically, this command will submit the spool file to the Samba host's print subsystem, using the suitable system print command. But there is no requirement that this needs to be the case. For debugging purposes or some other reason you may want to do something completely

different than "print" the file. An example is a command that just copies the print file to a temporary location for further investigation when you need to debug printing. If you craft your own print commands (or even develop print command shell scripts), make sure you pay attention to the need to remove the files from the Samba spool directory. Otherwise your hard disk may soon suffer from shortage of free space.

18.5.5. Default Print Commands for various Unix Print Subsystems

You learned earlier on, that Samba in most cases uses its built-in settings for many parameters if it can not find an explicitly stated one in its configuration file. The same is true for the print command. The default print command varies depending on the printing =... parameter setting. In the commands listed below, you will notice some parameters of the form %X where X is p, s, J etc. These letters stand for "printername", "spoolfile" and "job ID" respectively. They are explained in more detail further below. Here is an overview (excluding the special case of CUPS, which is discussed in the next chapter):

If this setting is active...	...this is used in lieu of an explicit command:
printing = bsd—aix—lprng—plp	print command is lpr -r -P%p %s
printing = sysv—hpux	print command is lp -c -P%p %s; rm %s
printing = qnx	print command is lp -r -P%p -s %s
printing = bsd—aix—lprng—plp	lpq command is lpq -P%p
printing = sysv—hpux	lpq command is lpstat -o%p
printing = qnx	lpq command is lpq -P%p
printing = bsd—aix—lprng—plp	lprm command is lprm -P%p %j
printing = sysv—hpux	lprm command is cancel %p-%j
printing = qnx	lprm command is cancel %p-%j
printing = bsd—aix—lprng—plp	lppause command is lp -i %p-%j -H hold
printing = sysv—hpux	lppause command (...is empty)
printing = qnx	lppause command (...is empty)
printing = bsd—aix—lprng—plp	lpresume command is lp -i %p-%j -H resume
printing = sysv—hpux	lpresume command (...is empty)
printing = qnx	lpresume command (...is empty)

We excluded the special CUPS case here, because it is discussed in the next chapter. Just a short summary. For printing = CUPS: If SAMBA is compiled against libcups, it uses the CUPS API to submit jobs, etc. (It is a good idea also to set printcap = cups in case your cupsd.conf is set to write its autogenerated printcap file to an unusual place). Otherwise Samba maps to the System V printing commands with the -oraw option for printing, i.e. it uses **lp -c -d%p -oraw; rm %s** With printing = cups , and if SAMBA is compiled against libcups, any manually set print command will be ignored!

Having listed the above mappings here, you should note that there used to be a *bug* in recent 2.2.x versions which prevented the mapping from taking effect. It led to the "bsd—aix—lprng—plp" settings taking effect for all other systems, for the most important commands (the **print** command, the **lpq** command and the **lprm** command). The **lppause** command and the **lpresume** command remained empty. Of course, these commands worked on bsd—aix—lprng—plp but they didn't work on sysv—hpux—qnx systems. To work around this bug, you need to explicitly set the commands. Use **testparm -v** to check which command takes effect. Then check

that this command is adequate and actually works for your installed print subsystem. It is always a good idea to explicitly set up your configuration files the way you want them to work and not rely on any built-in defaults.

18.5.6. Setting up your own Print Commands

After a print job has finished spooling to a service, the print command will be used by Samba via a *system()* call to process the spool file. Usually the command specified will submit the spool file to the host's printing subsystem. But there is no requirement at all that this must be the case. The print subsystem will probably not remove the spool file on its own. So whatever command you specify on your own you should ensure that the spool file is deleted after it has been processed.

There is no difficulty with using your own customized print commands with the traditional printing systems. However, if you don't wish to "roll your own", you should be well informed about the default built-in commands that Samba uses for each printing subsystem (see the table above). In all the commands listed in the last paragraphs you see parameters of the form *%X*. These are *macros*, or shortcuts, used as place holders for the names of real objects. At the time of running a command with such a placeholder, Samba will insert the appropriate value automatically. Print commands can handle all Samba macro substitutions. In regard to printing, the following ones do have special relevance:

- *%s*, *%f* - the path to the spool file name
- *%p* - the appropriate printer name
- *%J* - the job name as transmitted by the client.
- *%c* - the number of printed pages of the spooled job (if known).
- *%z* - the size of the spooled print job (in bytes)

The print command **MUST** contain at least one occurrence of *%s* or *%f*. – The *%p* is optional. If no printer name is supplied, the *%p* will be silently removed from the print command. In this case the job is sent to the default printer.

If specified in the [global] section, the print command given will be used for any printable service that does not have its own print command specified. If there is neither a specified print command for a printable service nor a global print command, spool files will be created but not processed! And (most importantly): print files will not be removed, so they will start filling your Samba hard disk.

Note that printing may fail on some UNIXes from the "nobody" account. If this happens, create an alternative guest account and supply it with the privilege to print. Set up this guest account in the [global] section with the guest account parameter.

You can form quite complex print commands. You need to realize that print commands are just passed to a UNIX shell. The shell is able to expand the included environment variables as usual. (The syntax to include a UNIX environment variable *\$variable* in or in the Samba print command is *%%\$variable*.) To give you a working print command example, the following will log a print job to */tmp/print.log*, print the file, then remove it. Note that *';* is the usual separator for commands in shell scripts:

```
print command = echo Printing %s >> /tmp/print.log; lpr -P %p %s; rm %s
```

You may have to vary your own command considerably from this example depending on how you normally print files on your system. The default for the print

command parameter varies depending on the setting of the printing parameter. Another example is:

```
print command = /usr/local/samba/bin/myprintscript %p %s
```

18.6. Innovations in Samba Printing since 2.2

Before version 2.2.0, Samba's print server support for Windows clients was limited to the level of *LanMan* printing calls. This is the same protocol level as Windows 9x PCs offer when they share printers. Beginning with the 2.2.0 release, Samba started to support the native Windows NT printing mechanisms. These are implemented via *MS-RPC* (RPC = *Remote Procedure Calls*). MS-RPCs use the *SPOOLSS* named pipe for all printing.

The additional functionality provided by the new SPOOLSS support includes:

- Support for downloading printer driver files to Windows 95/98/NT/2000 clients upon demand (*Point'n'Print*);
- Uploading of printer drivers via the Windows NT *Add Printer Wizard* (APW) or the *Imprints* tool set (refer to <http://imprints.sourceforge.net>);
- Support for the native MS-RPC printing calls such as *StartDocPrinter*, *EnumJobs()*, etc... (See the MSDN documentation at <http://msdn.microsoft.com/> for more information on the Win32 printing API);
- Support for NT *Access Control Lists* (ACL) on printer objects;
- Improved support for printer queue manipulation through the use of internal databases for spooled job information (implemented by various *.tdb files).

One other benefit of an update is this: Samba-3 is able to publish all its printers in Active Directory (or LDAP)!

One slight difference is here: it is possible on a Windows NT print server to have printers listed in the Printers folder which are *not* shared. Samba does not make this distinction. By definition, the only printers of which Samba is aware are those which are specified as shares in . The reason is that Windows NT/2k/XPprof clients do not normally need to use the standard SMB printer share; rather they can print directly to any printer on another Windows NT host using MS-RPC. This of course assumes that the printing client has the necessary privileges on the remote host serving the printer. The default permissions assigned by Windows NT to a printer gives the "Print" permissions to the well-known *Everyone* group. (The older clients of type Win9x can only print to "shared" printers).

18.6.1. Client Drivers on Samba Server for Point'n'Print

There is still confusion about what all this means: *Is it or is it not a requirement for printer drivers to be installed on a Samba host in order to support printing from Windows clients?* The answer to this is: No, it is not a *requirement*. Windows NT/2000 clients can, of course, also run their APW to install drivers *locally* (which then connect to a Samba served print queue). This is the same method as used by Windows 9x clients. (However, a *bug* existed in Samba 2.2.0 which made Windows NT/2000 clients require that the Samba server possess a valid driver for the printer. This was fixed in Samba 2.2.1).

But it is a new *option* to install the printer drivers into the [print\$] share of the Samba server, and a big convenience too. Then *all* clients (including 95/98/ME) get the driver installed when they first connect to this printer share. The *uploading*

or *depositing* of the driver into this [print\$] share, and the following binding of this driver to an existing Samba printer share can be achieved by different means:

- running the *APW* on an NT/2k/XPprof client (this doesn't work from 95/98/ME clients);
- using the *Imprints* toolset;
- using the *smbclient* and *rpcclient* commandline tools;
- using *cupsaddsmb* (only works for the CUPS printing system, not for LPR/LPD, LPRng etc.).

Please take additional note of the following fact: *Samba does not use these uploaded drivers in any way to process spooled files.* Drivers are utilized entirely by the clients, who download and install them via the "Point 'n'Print" mechanism supported by Samba. The clients use these drivers to generate print files in the format the printer (or the Unix print system) requires. Print files received by Samba are handed over to the Unix printing system, which is responsible for all further processing, if needed.

18.6.2. The [printer\$] Section is removed from Samba-3

[print\$] vs. [printer\$] Versions of Samba prior to 2.2 made it possible to use a share named *[printer\$]*. This name was taken from the same named service created by Windows 9x clients when a printer was shared by them. Windows 9x printer servers always have a [printer\$] service which provides read-only access (with no password required) in order to support printer driver downloads. However, Samba's initial implementation allowed for a parameter named printer driver location to be used on a per share basis. This specified the location of the driver files associated with that printer. Another parameter named printer driver provided a means of defining the printer driver name to be sent to the client. These parameters, including the printer driver file parameter, are now removed and can not be used in installations of Samba-3.0. Now the share name [print\$] is used for the location of downloadable printer drivers. It is taken from the [print\$] service created by Windows NT PCs when a printer is shared by them. Windows NT print servers always have a [print\$] service which provides read-write access (in the context of its ACLs) in order to support printer driver down- and uploads. Don't fear – this does not mean Windows 9x clients are thrown aside now. They can use Samba's [print\$] share support just fine.

18.6.3. Creating the [print\$] Share

In order to support the up- and downloading of printer driver files, you must first configure a file share named [print\$]. The "public" name of this share is hard coded in Samba's internals (because it is hardcoded in the MS Windows clients too). It cannot be renamed since Windows clients are programmed to search for a service of exactly this name if they want to retrieve printer driver files.

You should modify the server's file to add the global parameters and create the [print\$] file share (of course, some of the parameter values, such as 'path' are arbitrary and should be replaced with appropriate values for your site):

```
[global]
    ; members of the ntadmin group should be able to add drivers and set
    ; printer properties. root is implicitly always a 'printer admin'.
    printer admin = @ntadmin
    [....]
```

```
[printers]
[....]

[print$]
comment = Printer Driver Download Area
path = /etc/samba/drivers
browseable = yes
guest ok = yes
read only = yes
write list = @ntadmin, root
```

Of course, you also need to ensure that the directory named by the path parameter exists on the Unix file system.

18.6.4. Parameters in the [print\$] Section

[print\$] is a special section in . It contains settings relevant to potential printer driver download and local installation by clients.

comment = Printer Driver Download Area the comment appears next to the share name if it is listed in a share list (usually Windows clients won't see it often but it will also appear up in a **smbclient -L sambaserver** output).

path = /etc/samba/printers this is the path to the location of the Windows driver file deposit from the UNIX point of view.

browseable = no this makes the [print\$] share "invisible" in Network Neighbourhood to clients. However, you can still "mount" it from any client using the **net use g:\sambaserver\print\$** command in a "DOS box" or the "Connect network drive" menu from Windows Explorer.

guest ok = yes this gives read only access to this share for all guest users. Access may be used to download and install printer drivers on clients. The requirement for guest ok = yes depends upon how your site is configured. If users will be guaranteed to have an account on the Samba host, then this is a non-issue.

NOTE



The non-issue is this: if all your Windows NT users are guaranteed to be authenticated by the Samba server (for example if Samba authenticates via an NT domain server and the NT user has already been validated by the Domain Controller in order to logon to the Windows NT session), then guest access is not necessary. Of course, in a workgroup environment where you just want to be able to print without worrying about silly accounts and security, then configure the share for guest access. You'll probably want to add map to guest = Bad User in the [global] section as well. Make sure you understand what this parameter does before using it.

read only = yes as we don't want everybody to upload driver files (or even change driver settings) we tagged this share as not writeable.

write list = @ntadmin,root since the [print\$] was made read only by the previous setting, we need to create a "write list" also. UNIX groups (denoted with

a leading "@" character) and users listed here are allowed write access (as an exception to the general public's "read-only" access), which they need to update files on the share. Normally you will want to only name administrative level user accounts in this setting. Check the file system permissions to make sure these accounts can copy files to the share. If this is a non-root account, then the account should also be mentioned in the global printer admin parameter. See the man page for more information on configuring file shares.

18.6.5. Subdirectory Structure in [print\$]

In order for a Windows NT print server to support the downloading of driver files by multiple client architectures, you must create several subdirectories within the [print\$] service (i.e. the Unix directory named by the path parameter). These correspond to each of the supported client architectures. Samba follows this model as well. Just like the name of the [print\$] share itself, the subdirectories *must* be exactly the names listed below (you may leave out the subdirectories of architectures you don't want to support).

Therefore, create a directory tree below the [print\$] share for each architecture you wish to support.

```
[print$]--+--
|--W32X86           # serves drivers to "Windows NT x86"
|--WIN40            # serves drivers to "Windows 95/98"
|--W32ALPHA         # serves drivers to "Windows NT Alpha_AXP"
|--W32MIPS          # serves drivers to "Windows NT R4000"
|--W32PPC           # serves drivers to "Windows NT PowerPC"
```

REQUIRED PERMISSIONS

In order to add a new driver to your Samba host, one of two conditions must hold true:



- The account used to connect to the Samba host must have a UID of 0 (i.e. a root account)
- The account used to connect to the Samba host must be named in the *printer adminlist*.

Of course, the connected account must still possess access to add files to the subdirectories beneath [print\$]. Remember that all file shares are set to 'read only' by default.

Once you have created the required [print\$] service and associated subdirectories, go to a Windows NT 4.0/2k/XP client workstation. Open **Network Neighbourhood** or **My Network Places** and browse for the Samba host. Once you have located the server, navigate to its **Printers and Faxes** folder. You should see an initial listing of printers that matches the printer shares defined on your Samba host.

18.7. Installing Drivers into [print\$]

You have successfully created the [print\$] share in ? And Samba has re-read its configuration? Good. But you are not yet ready to take off. The *driver files* need to be present in this share, too! So far it is still an empty share. Unfortunately, it is not enough to just copy the driver files over. They need to be *set up* too. And that is a bit tricky, to say the least. We will now discuss two alternative ways to install the drivers into [print\$]:

- using the Samba commandline utility **rpcclient** with its various subcommands (here: **adddriver** and **setdriver**) from any UNIX workstation;
- running a GUI (*Printer Properties* and *Add Printer Wizard*) from any Windows NT/2k/XP client workstation.

The latter option is probably the easier one (even if the only entrance to this realm seems a little bit weird at first).

18.7.1. Setting Drivers for existing Printers with a Client GUI

The initial listing of printers in the Samba host's **Printers** folder accessed from a client's Explorer will have no real printer driver assigned to them. By default, in Samba-3 (as in 2.2.1 and later) this driver name is set to a NULL string. This must be changed now. The local *Add Printer Wizard*, run from NT/2000/XP clients, will help us in this task.

However, the job to set a valid driver for the printer is not a straightforward one: You must attempt to view the printer properties for the printer to which you want the driver assigned. Open the Windows Explorer, open Network Neighbourhood, browse to the Samba host, open Samba's **Printers** folder, right-click the printer icon and select **Properties...** You are now trying to view printer and driver properties for a queue which has this default NULL driver assigned. This will result in an error message (this is normal here):

Device settings cannot be displayed. The driver for the specified printer is not installed, only spooler properties will be displayed. Do you want to install the driver now?

Important: Don't click **Yes!** Instead, *click No* in the error dialog. Only now you will be presented with the printer properties window. From here, the way to assign a driver to a printer is open to us. You have now the choice either:

- select a driver from the popup list of installed drivers. *Initially this list will be empty.* Or
- use the **New Driver...** button to install a new printer driver (which will in fact start up the APW).

Once the APW is started, the procedure is exactly the same as the one you are familiar with in Windows (we assume here that you are familiar with the printer driver installations procedure on Windows NT). Make sure your connection is in fact setup as a user with printer admin privileges (if in doubt, use **smbstatus** to check for this). If you wish to install printer drivers for client operating systems other than Windows NT x86, you will need to use the **Sharing** tab of the printer properties dialog.

Assuming you have connected with an administrative (or root) account (as named by the printer admin parameter), you will also be able to modify other printer properties such as ACLs and default device settings using this dialog. For the default device settings, please consider the advice given further below.

18.7.2. Setting Drivers for existing Printers with `rpcclient`

The second way to install printer drivers into `[print$]` and set them up in a valid way can be done from the UNIX command line. This involves four distinct steps:

1. gathering the info about the required driver files and collecting the files together;
2. deposit the driver files into the `[print$]` share's correct subdirectories (possibly by using `smbclient`);
3. running the `rpcclient` commandline utility once with the `addriver` subcommand,
4. running `rpcclient` a second time with the `setdriver` subcommand.

We will provide detailed hints for each of these steps in the next few paragraphs.

18.7.2.1. Identifying the Driver Files

To find out about the driver files, you have two options: you could investigate the driver CD which comes with your printer. Study the `*.inf` file on the CD, if it is contained. This may not be the possible, since the `*.inf` file might be missing. Unfortunately, many vendors have now started to use their own installation programs. These installations packages are often some sort of Windows platform archive format, plus, the files may get re-named during the installation process. This makes it extremely difficult to identify the driver files you need.

Then you only have the second option: install the driver first on a Windows client `*locally*` and investigate which file names and paths it uses after they are installed. (Note, that you need to repeat this procedure for every client platform you want to support. We are going to show it here for the W32X86 platform only, a name used by Microsoft for all WinNT/2k/XP clients...)

A good method to recognize the driver files this is to print the test page from the driver's **Properties** Dialog (**General** tab). Then look at the list of driver files named on the printout. You'll need to recognize what Windows (and Samba) are calling the **Driver File**, the **Data File**, the **Config File**, the **Help File** and (optionally) the **Dependent Driver Files** (this may vary slightly for Windows NT). You need to remember all names (or better take a note) for the next steps.

Another method to quickly test the driver filenames and related paths is provided by the `rpcclient` utility. Run it with `enumdrivers` or with the `getdriver` subcommand, each in the `3` level. In the following example, `TURBO_XP` is the name of the Windows PC (in this case it was a Windows XP Professional laptop, BTW). I had installed the driver locally to `TURBO_XP` while `kde-bitshop` is the name of the Linux host from which I am working. We could run an *interactive* `rpcclient` session; then we'd get an `rpcclient />` prompt and would type the subcommands at this prompt. This is left as a good exercise to the reader. For now we use `rpcclient` with the `-c` parameter to execute a single subcommand line and exit again. This is the method you would use if you want to create scripts to automate the procedure for a large number of printers and drivers. Note the different quotes used to overcome the different spaces in between words:

```
root# rpcclient -U'Danka%xxxx' -c 'getdriver "Heidelberg Digimaster 9110 (PS)" 3' TURBO_XP
cmd = getdriver "Heidelberg Digimaster 9110 (PS)" 3
```

```
[Windows NT x86]
```

```
Printer Driver Info 3:
```

```
Version: [2]
```

```
Driver Name: [Heidelberg Digimaster 9110 (PS)]
```



```
Architecture: [Windows NT x86]
Driver Path: [C:\WINNT\System32\spool\DRIVERS\W32X86\2\HDNIS01_de.DLL]
Datafile: [C:\WINNT\System32\spool\DRIVERS\W32X86\2\Hddm91c1_de.ppd]
Configfile: [C:\WINNT\System32\spool\DRIVERS\W32X86\2\HDNIS01U_de.DLL]
Helpfile: [C:\WINNT\System32\spool\DRIVERS\W32X86\2\HDNIS01U_de.HLP]

Dependentfiles: [C:\WINNT\System32\spool\DRIVERS\W32X86\2\Hddm91c1_de.DLL]
Dependentfiles: [C:\WINNT\System32\spool\DRIVERS\W32X86\2\Hddm91c1_de.INI]
Dependentfiles: [C:\WINNT\System32\spool\DRIVERS\W32X86\2\Hddm91c1KMMIn.DLL]
Dependentfiles: [C:\WINNT\System32\spool\DRIVERS\W32X86\2\Hddm91c1_de.dat]
Dependentfiles: [C:\WINNT\System32\spool\DRIVERS\W32X86\2\Hddm91c1_de.cat]
Dependentfiles: [C:\WINNT\System32\spool\DRIVERS\W32X86\2\Hddm91c1_de.def]
Dependentfiles: [C:\WINNT\System32\spool\DRIVERS\W32X86\2\Hddm91c1_de.hre]
Dependentfiles: [C:\WINNT\System32\spool\DRIVERS\W32X86\2\Hddm91c1_de.vnd]
Dependentfiles: [C:\WINNT\System32\spool\DRIVERS\W32X86\2\Hddm91c1_de.hlp]
Dependentfiles: [C:\WINNT\System32\spool\DRIVERS\W32X86\2\Hddm91c1_de_reg.f]
Dependentfiles: [C:\WINNT\System32\spool\DRIVERS\W32X86\2\HDNIS01Aux.dll]
Dependentfiles: [C:\WINNT\System32\spool\DRIVERS\W32X86\2\HDNIS01_de.NTF]

Monitorname: []
Defaultdatatype: []
```

You may notice, that this driver has quite a big number of **Dependentfiles** (I know worse cases however). Also, strangely, the **Driver File** is here tagged as **Driver Path....** oh, well. Here we don't have yet support for the so-called WIN40 architecture installed. This name is used by Microsoft for the Win95/98/ME platforms. If we want to support these, we need to install the Win95/98/ME driver files in addition to those for W32X86 (i.e. the WinNT72000/XP clients) onto a Windows PC. This PC can also host the Win9x drivers, even if itself runs on Windows NT, 2000 or XP.

Since the [print\$] share is usually accessible through the **Network Neighbourhood**, you can also use the UNC notation from Windows Explorer to poke at it. The Win9x driver files will end up in subdirectory "0" of the "WIN40" directory. The full path to access them will be \\WINDOWSHOST\print\$\WIN40\0\.

NOTE

more recent drivers on Windows 2000 and Windows XP are installed into the "3" subdirectory instead of the "2". The version 2 of drivers, as used in Windows NT, were running in Kernel Mode. Windows 2000 changed this. While it still can use the Kernel Mode drivers (if this is enabled by the Admin), its native mode for printer drivers is User Mode execution. This requires drivers designed for this. These type of drivers install into the "3" subdirectory.

18.7.2.2. Collecting the Driver Files from a Windows Host's [print\$] Share

Now we need to collect all the driver files we identified. in our previous step. Where do we get them from? Well, why not retrieve them from the very PC and the same [print\$] share which we investigated in our last step to identify the files? We can use **smbclient** to do this. We will use the paths and names which were leaked to us by **getdriver**. The listing is edited to include linebreaks for readability:

```
root# smbclient //TURBO_XP/print\$ -U'Danka%xxxx' \
  -c 'cd W32X86/2;mget HD*_de.* \
    hd*ppd Hd*_de.* Hddm*dll HDN*Aux.DLL'
added interface ip=10.160.51.60 bcast=10.160.51.255 nmask=255.255.252.0
Got a positive name query response from 10.160.50.8 ( 10.160.50.8 )
Domain=[DEVELOPMENT] OS=[Windows 5.1] Server=[Windows 2000 LAN Manager]
Get file Hddm91c1_de.ABD? n
Get file Hddm91c1_de.def? y
getting file \\W32X86\2\Hddm91c1_de.def of size 428 as Hddm91c1_de.def (22.0 kb/s)
Get file Hddm91c1_de.DLL? y
getting file \\W32X86\2\Hddm91c1_de.DLL of size 876544 as Hddm91c1_de.DLL (737.3 kb)
[...]
```

After this command is complete, the files are in our current local directory. You probably have noticed that this time we passed several commands to the `-c` parameter, separated by semi-colons. This effects that all commands are executed in sequence on the remote Windows server before **smbclient** exits again.

Don't forget to repeat the procedure for the WIN40 architecture should you need to support Win95/98/XP clients. Remember, the files for these architectures are in the WIN40/0/ subdir. Once we are complete, we can run **smbclient ... put** to store the collected files on the Samba server's [print\$] share.

18.7.2.3. Depositing the Driver Files into [print\$]

So, now we are going to put the driver files into the [print\$] share. Remember, the UNIX path to this share has been defined previously in your `.`. You also have created subdirectories for the different Windows client types you want to support. Supposing your [print\$] share maps to the UNIX path `/etc/samba/drivers/`, your driver files should now go here:

- for all Windows NT, 2000 and XP clients into `/etc/samba/drivers/W32X86/` but **not*(yet) into the "2" subdir!*
- for all Windows 95, 98 and ME clients into `/etc/samba/drivers/WIN40/` – but **not*(yet) into the "0" subdir!*

We again use **smbclient** to transfer the driver files across the network. We specify the same files and paths as were leaked to us by running **getdriver** against the original *Windows* install. However, now we are going to store the files into a *Samba/UNIX* print server's [print\$] share...

```
root# smbclient //SAMBA-CUPS/print\$ -U'root%xxxx' -c 'cd W32X86; put HDNIS01_de.DLL
  put Hddm91c1_de.ppd; put HDNIS01U_de.DLL; \
  put HDNIS01U_de.HLP; put Hddm91c1_de.DLL; \
  put Hddm91c1_de.INI; put Hddm91c1KMMin.DLL; \
  put Hddm91c1_de.dat; put Hddm91c1_de.dat; \
```

```

put Hddm91c1_de.def; put Hddm91c1_de.hre;      \
put Hddm91c1_de.vnd; put Hddm91c1_de.hlp;     \
put Hddm91c1_de_reg.HLP; put HDNIS01Aux.dll;   \
put HDNIS01_de.NTF'
added interface ip=10.160.51.60 bcast=10.160.51.255 nmask=255.255.252.0
Got a positive name query response from 10.160.51.162 ( 10.160.51.162 )
Domain=[CUPS-PRINT] OS=[Unix] Server=[Samba 2.2.7a]
putting file HDNIS01_de.DLL as \W32X86\HDNIS01_de.DLL (4465.5 kb/s) (average 4465.5
putting file Hddm91c1_de.ppd as \W32X86\Hddm91c1_de.ppd (12876.8 kb/s) (average 463
putting file HDNIS01U_de.DLL as \W32X86\HDNIS01U_de.DLL (20249.8 kb/s) (average 582
putting file HDNIS01U_de.HLP as \W32X86\HDNIS01U_de.HLP (9652.8 kb/s) (average 5899
putting file Hddm91c1_de.DLL as \W32X86\Hddm91c1_de.DLL (23777.7 kb/s) (average 104
putting file Hddm91c1_de.INI as \W32X86\Hddm91c1_de.INI (98.6 kb/s) (average 10329.
putting file Hddm91c1KMMIn.DLL as \W32X86\Hddm91c1KMMIn.DLL (22931.5 kb/s) (average
putting file Hddm91c1_de.dat as \W32X86\Hddm91c1_de.dat (2462.8 kb/s) (average 1039
putting file Hddm91c1_de.dat as \W32X86\Hddm91c1_de.dat (4925.3 kb/s) (average 1035
putting file Hddm91c1_de.def as \W32X86\Hddm91c1_de.def (417.9 kb/s) (average 10290
putting file Hddm91c1_de.hre as \W32X86\Hddm91c1_de.hre (22571.3 kb/s) (average 113
putting file Hddm91c1_de.vnd as \W32X86\Hddm91c1_de.vnd (3384.6 kb/s) (average 1075
putting file Hddm91c1_de.hlp as \W32X86\Hddm91c1_de.hlp (18406.8 kb/s) (average 108
putting file Hddm91c1_de_reg.HLP as \W32X86\Hddm91c1_de_reg.HLP (20278.3 kb/s) (aver
putting file HDNIS01Aux.dll as \W32X86\HDNIS01Aux.dll (14994.6 kb/s) (average 11405
putting file HDNIS01_de.NTF as \W32X86\HDNIS01_de.NTF (23390.2 kb/s) (average 13170

```

Phewww – that was a lot of typing! Most drivers are a lot smaller – many only having 3 generic PostScript driver files plus 1 PPD. Note, that while we did retrieve the files from the "2" subdirectory of the "W32X86" directory from the Windows box, we *don't* put them (for now) in this same subdirectory of the Samba box! This re-location will automatically be done by the **adddriver** command which we will run shortly (and don't forget to also put the files for the Win95/98/ME architecture into the WIN40/ subdirectory should you need them).

18.7.2.4. Check if the Driver Files are there (with smbclient)

For now we verify that our files are there. This can be done with **smbclient** too (but of course you can log in via SSH also and do this through a standard UNIX shell access too):

```

root# smbclient //SAMBA-CUPS/print\$ -U 'root%xxxx' -c 'cd W32X86; pwd; dir; cd 2; p
added interface ip=10.160.51.60 bcast=10.160.51.255 nmask=255.255.252.0
Got a positive name query response from 10.160.51.162 ( 10.160.51.162 )
Domain=[CUPS-PRINT] OS=[Unix] Server=[Samba 2.2.7a]

Current directory is \\SAMBA-CUPS\print\$\W32X86\
.                D            0  Sun May  4 03:56:35 2003
..               D            0  Thu Apr 10 23:47:40 2003
2                D            0  Sun May  4 03:56:18 2003
HDNIS01Aux.dll   A       15356  Sun May  4 03:58:59 2003
Hddm91c1KMMIn.DLL A       46966  Sun May  4 03:58:59 2003
HDNIS01_de.DLL   A     434400  Sun May  4 03:58:59 2003
HDNIS01_de.NTF   A     790404  Sun May  4 03:56:35 2003

```

```

Hddm91c1_de.DLL          A   876544  Sun May  4 03:58:59 2003
Hddm91c1_de.INI         A     101   Sun May  4 03:58:59 2003
Hddm91c1_de.dat         A    5044   Sun May  4 03:58:59 2003
Hddm91c1_de.def         A     428   Sun May  4 03:58:59 2003
Hddm91c1_de.hlp         A    37699  Sun May  4 03:58:59 2003
Hddm91c1_de.hre         A   323584  Sun May  4 03:58:59 2003
Hddm91c1_de.ppd         A    26373  Sun May  4 03:58:59 2003
Hddm91c1_de.vnd         A    45056  Sun May  4 03:58:59 2003
HDNIS01U_de.DLL         A   165888  Sun May  4 03:58:59 2003
HDNIS01U_de.HLP         A    19770  Sun May  4 03:58:59 2003
Hddm91c1_de_reg.HLP     A   228417  Sun May  4 03:58:59 2003
40976 blocks of size 262144. 709 blocks available

```

```

Current directory is \\SAMBA-CUPS\print$\W32X86\2\
.          D         0   Sun May  4 03:56:18 2003
..         D         0   Sun May  4 03:56:35 2003
ADOBEPS5.DLL  A   434400  Sat May  3 23:18:45 2003
laserjet4.ppd A    9639   Thu Apr 24 01:05:32 2003
ADOBEPSU.DLL  A   109568  Sat May  3 23:18:45 2003
ADOBEPSU.HLP  A    18082  Sat May  3 23:18:45 2003
PDFcreator2.PPD A   15746   Sun Apr 20 22:24:07 2003
40976 blocks of size 262144. 709 blocks available

```

Notice that there are already driver files present in the 2 subdir (probably from a previous installation). Once the files for the new driver are there too, you are still a few steps away from being able to use them on the clients. The only thing you could do *now* is to retrieve them from a client just like you retrieve ordinary files from a file share, by opening `print$` in Windows Explorer. But that wouldn't install them per Point'n'Print. The reason is: Samba doesn't know yet that these files are something special, namely *printer driver files* and it doesn't know yet to which print queue(s) these driver files belong.

18.7.2.5. Running `rpcclient` with `adddriver`

So, next you must tell Samba about the special category of the files you just uploaded into the `[print$]` share. This is done by the `adddriver` command. It will prompt Samba to register the driver files into its internal TDB database files. The following command and its output has been edited, again, for readability:

```

root# rpcclient -Uroot%xxxx -c 'adddriver "Windows NT x86" "dm9110:HDNIS01_de.DLL: \
Hddm91c1_de.ppd:HDNIS01U_de.DLL:HDNIS01U_de.HLP: \
NULL:RAW:Hddm91c1_de.DLL,Hddm91c1_de.INI, \
Hddm91c1_de.dat,Hddm91c1_de.def,Hddm91c1_de.hre, \
Hddm91c1_de.vnd,Hddm91c1_de.hlp,Hddm91c1KMMin.DLL, \
HDNIS01Aux.dll,HDNIS01_de.NTF, \
Hddm91c1_de_reg.HLP' SAMBA-CUPS

cmd = adddriver "Windows NT x86" "dm9110:HDNIS01_de.DLL:Hddm91c1_de.ppd:HDNIS01U_de
HDNIS01U_de.HLP:NULL:RAW:Hddm91c1_de.DLL,Hddm91c1_de.INI, \
Hddm91c1_de.dat,Hddm91c1_de.def,Hddm91c1_de.hre, \
Hddm91c1_de.vnd,Hddm91c1_de.hlp,Hddm91c1KMMin.DLL, \

```

```
HDNIS01Aux.dll,HDNIS01_de.NTF,Hddm91c1_de_reg.HLP"
```

Printer Driver dm9110 successfully installed.

After this step the driver should be recognized by Samba on the print server. You need to be very careful when typing the command. Don't exchange the order of the fields. Some changes would lead to a `NT_STATUS_UNSUCCESSFUL` error message. These become obvious. Other changes might install the driver files successfully, but render the driver unworkable. So take care! Hints about the syntax of the `adddriver` command are in the man page. The CUPS printing chapter of this HOWTO collection provides a more detailed description, if you should need it.

18.7.2.6. Check how Driver Files have been moved after `adddriver` finished

One indication for Samba's recognition of the files as driver files is the `successfully installed` message. Another one is the fact, that our files have been moved by the `adddriver` command into the 2 subdirectory. You can check this again with `smbclient`:

```
root# smbclient //SAMBA-CUPS/print$ -Uroot%xxxx -c 'cd W32X86;dir;pwd;cd 2;dir;pwd'
added interface ip=10.160.51.162 bcast=10.160.51.255 nmask=255.255.252.0
Domain=[CUPS-PRINT] OS=[Unix] Server=[Samba 2.2.7a]
```

```
Current directory is \\SAMBA-CUPS\print$\W32X86\
.                               D           0 Sun May  4 04:32:48 2003
..                              D           0 Thu Apr 10 23:47:40 2003
2                               D           0 Sun May  4 04:32:48 2003
                                40976 blocks of size 262144. 731 blocks available
```

```
Current directory is \\SAMBA-CUPS\print$\W32X86\2\
.                               D           0 Sun May  4 04:32:48 2003
..                              D           0 Sun May  4 04:32:48 2003
DigiMaster.PPD                 A    148336 Thu Apr 24 01:07:00 2003
ADOBEPS5.DLL                   A    434400 Sat May  3 23:18:45 2003
laserjet4.ppd                  A     9639 Thu Apr 24 01:05:32 2003
ADOBEPSU.DLL                   A   109568 Sat May  3 23:18:45 2003
ADOBEPSU.HLP                   A    18082 Sat May  3 23:18:45 2003
PDFcreator2.PPD                A    15746 Sun Apr 20 22:24:07 2003
HDNIS01Aux.dll                 A    15356 Sun May  4 04:32:18 2003
Hddm91c1KMMin.DLL              A    46966 Sun May  4 04:32:18 2003
HDNIS01_de.DLL                 A   434400 Sun May  4 04:32:18 2003
HDNIS01_de.NTF                 A   790404 Sun May  4 04:32:18 2003
Hddm91c1_de.DLL                A   876544 Sun May  4 04:32:18 2003
Hddm91c1_de.INI                A     101 Sun May  4 04:32:18 2003
Hddm91c1_de.dat                A    5044 Sun May  4 04:32:18 2003
Hddm91c1_de.def                A     428 Sun May  4 04:32:18 2003
Hddm91c1_de.hlp                A    37699 Sun May  4 04:32:18 2003
Hddm91c1_de.hre                A   323584 Sun May  4 04:32:18 2003
Hddm91c1_de.ppd                A    26373 Sun May  4 04:32:18 2003
Hddm91c1_de.vnd                A    45056 Sun May  4 04:32:18 2003
HDNIS01U_de.DLL                A   165888 Sun May  4 04:32:18 2003
```

```
HDNIS01U_de.HLP          A    19770  Sun May  4 04:32:18 2003
Hddm91c1_de_reg.HLP     A    228417 Sun May  4 04:32:18 2003
                        40976 blocks of size 262144. 731 blocks available
```

Another verification is that the timestamp of the printing TDB files is now updated (and possibly their filesize has increased).

18.7.2.7. Check if the Driver is recognized by Samba

Now the driver should be registered with Samba. We can easily verify this, and will do so in a moment. However, this driver is *not yet* associated with a particular *printer*. We may check the driver status of the files by at least three methods:

- from any Windows client browse Network Neighbourhood, find the Samba host and open the Samba **Printers and Faxes** folder. Select any printer icon, right-click and select the printer **Properties**. Click on the **Advanced** tab. Here is a field indicating the driver for that printer. A drop down menu allows you to change that driver (be careful to not do this unwittingly.). You can use this list to view all drivers known to Samba. Your new one should be amongst them. (Each type of client will only see his own architecture's list. If you don't have every driver installed for each platform, the list will differ if you look at it from Windows95/98/ME or WindowsNT/2000/XP.)
- from a Windows 2000 or XP client (not WinNT) browse **Network Neighbourhood**, search for the Samba server and open the server's **Printers** folder, right-click the white background (with no printer highlighted). Select **Server Properties**. On the **Drivers** tab you will see the new driver listed now. This view enables you to also inspect the list of files belonging to that driver (*this doesn't work on Windows NT, but only on Windows 2000 and Windows XP. WinNT doesn't provide the "Drivers" tab*). An alternative, much quicker method for Windows 2000/XP to start this dialog is by typing into a DOS box (you must of course adapt the name to your Samba server instead of SAMBA-CUPS):
rundll32 printui.dll,PrintUIEntry /s /t2 /n\\SAMBA-CUPS
- from a UNIX prompt run this command (or a variant thereof), where SAMBA-CUPS is the name of the Samba host and "xxxx" represents the actual Samba password assigned to root:
rpcclient -U'root%xxxx' -c 'enumdrivers' SAMBA-CUPS
You will see a listing of all drivers Samba knows about. Your new one should be amongst them. But it is only listed under the [Windows NT x86] heading, not under [Windows 4.0], since we didn't install that part. Or did *you*? – You will see a listing of all drivers Samba knows about. Your new one should be amongst them. In our example it is named *dm9110*. Note that the 3rd column shows the other installed drivers twice, for each supported architecture one time. Our new driver only shows up for Windows NT 4.0 or 2000. To have it present for Windows 95, 98 and ME you'll have to repeat the whole procedure with the WIN40 architecture and subdirectory.

18.7.2.8. A sidenote: you are not bound to specific driver names

You can name the driver as you like. If you repeat the **adddriver** step, with the same files as before, but with a different driver name, it will work the same:

```
root# rpcclient -Uroot%xxxx \
```

```
-c 'adddriver "Windows NT x86" \
"myphantasydrivername:HDNIS01_de.DLL: \
Hddm91c1_de.ppd:HDNIS01U_de.DLL:HDNIS01U_de.HLP: \
NULL:RAW:Hddm91c1_de.DLL,Hddm91c1_de.INI, \
Hddm91c1_de.dat,Hddm91c1_de.def,Hddm91c1_de.hre, \
Hddm91c1_de.vnd,Hddm91c1_de.hlp,Hddm91c1KMMin.DLL, \
HDNIS01Aux.dll,HDNIS01_de.NTF,Hddm91c1_de_reg.HLP' SAMBA-CUPS
```

```
cmd = adddriver "Windows NT x86"
      "myphantasydrivername:HDNIS01_de.DLL:Hddm91c1_de.ppd:HDNIS01U_de.DLL:
      HDNIS01U_de.HLP:NULL:RAW:Hddm91c1_de.DLL,Hddm91c1_de.INI,
      Hddm91c1_de.dat,Hddm91c1_de.def,Hddm91c1_de.hre,
      Hddm91c1_de.vnd,Hddm91c1_de.hlp,Hddm91c1KMMin.DLL,
      HDNIS01Aux.dll,HDNIS01_de.NTF,Hddm91c1_de_reg.HLP"
```

Printer Driver myphantasydrivername successfully installed.

You will also be able to bind that driver to any print queue (however, you are responsible yourself that you associate drivers to queues which make sense to the target printer). Note, that you can't run the **rpcclient adddriver** command repeatedly. Each run "consumes" the files you had put into the [print\$] share by moving them into the respective subdirectories. So you *must* precede an **smbclient ... put** command before each **rpcclient ... adddriver** command.

18.7.2.9. La Grande Finale: Running rpcclient with setdriver

Samba still needs to know *which* printer's driver this is. It needs to create a mapping of the driver to a printer, and store this info in its "memory", the TDB files. The **rpcclient setdriver** command achieves exactly this:

```
root# rpcclient -U'root%xxxx' -c 'setdriver dm9110 myphantasydrivername' SAMBA-CUPS
cmd = setdriver dm9110 myphantasydrivername
Successfully set dm9110 to driver myphantasydrivername.
```

Ahhhhh – no, I didn't want to do that. Repeat, this time with the name I intended:

```
root# rpcclient -U'root%xxxx' -c 'setdriver dm9110 dm9110' SAMBA-CUPS
cmd = setdriver dm9110 dm9110
Successfully set dm9110 to driver dm9110.
```

The syntax of the command is `rpcclient -U'root%sambapassword' -c 'setdriver "printername" "drivername' SAMBA-Hostname .` – Now we have done *most* of the work. But not yet all....

NOTE



the **setdriver** command will only succeed if the printer is known to Samba already. A bug in 2.2.x prevented Samba from recognizing freshly installed printers. You had to restart Samba, or at least send a HUP signal to all running `smbd` processes to work around this: `kill -HUP `pidof smbd``.

18.8. "The Proof of the Pudding lies in the Eating" (Client Driver Insta Procedure)

A famous philosopher said once: 'The Proof of the Pudding lies in the Eating'. The proof for our setup lies in the printing. So let's install the printer driver onto the client PCs. This is not as straightforward as it may seem. Read on.

18.8.1. The first Client Driver Installation

Especially important is the installation onto the first client PC (for each architectural platform separately). Once this is done correctly, all further clients are easy to setup and shouldn't need further attention. What follows is a description for the recommended first procedure. You work now from a client workstation. First you should guarantee that your connection is not unwittingly mapped to bad user "nobody". In a DOS box type:

```
net use \\SAMBA-SERVER\print$ /user:root
```

Replace `root`, if needed, by another valid printer admin user as given in the definition. Should you already be connected as a different user, you'll get an error message. There is no easy way to get rid of that connection, because Windows doesn't seem to know a concept of "logging off" from a share connection (don't confuse this with logging off from the local workstation; that is a different matter). You can try to close *all* Windows file explorer and Internet Explorer windows. As a last resort, you may have to reboot. Make sure there is no automatic re-connection set up. It may be easier to go to a different workstation and try from there. After you have made sure you are connected as a printer admin user (you can check this with the **smbstatus** command on Samba) do this from the Windows workstation:

- Open **Network Neighbourhood**
- Browse to Samba server
- Open its **Printers and Faxes** folder
- Highlight and right-click the printer
- Select **Connect...** (for WinNT4/2K it is possibly **Install...**)

A new printer (named `printername` on `samba-server`) should now have appeared in your *local* Printer folder (check **Start – Settings – Control Panel – Printers and Faxes**).

Most likely you are now tempted to try and print a test page. After all, you now can open the printer properties and on the "General" tab, there is a button offering to do just that. But chances are that you get an error message saying Unable to print Test Page. The reason might be that there is not yet a valid Device Mode set for the driver, or that the "Printer Driver Data" set is still incomplete.

You must now make sure that a valid "Device Mode" is set for the driver. Don't fear – we will explain now what that means.

18.8.2. IMPORTANT! Setting Device Modes on new Printers

In order for a printer to be truly usable by a Windows NT/2K/XP client, it must possess:

- a valid *Device Mode* generated by the driver for the printer (defining things like paper size, orientation and duplex settings), and
- a complete set of *Printer Driver Data* generated by the driver.

If either one of these is incomplete, the clients can produce less than optimal output at best. In the worst cases, unreadable garbage or nothing at all comes from the printer or they produce a harvest of error messages when attempting to print. Samba stores the named values and all printing related info in its internal TDB database files (`ntprinters.tdb`, `ntdrivers.tdb`, `printing.tdb` and `ntforms.tdb`).

What do these two words stand for? Basically, the Device Mode and the set of Printer Driver Data is a collection of settings for all print queue properties, initialized in a sensible way. Device Modes and Printer Driver Data should initially be set on the print server (that is here: the Samba host) to healthy values so that the clients can start to use them immediately. How do we set these initial healthy values? This can be achieved by accessing the drivers remotely from an NT (or 2k/XP) client, as is discussed in the next paragraphs.

Be aware, that a valid Device Mode can only be initiated by a printer admin, or root (the reason should be obvious). Device Modes can only correctly be set by executing the printer driver program itself. Since Samba can not execute this Win32 platform driver code, it sets this field initially to NULL (which is not a valid setting for clients to use). Fortunately, most drivers generate themselves the Printer Driver Data that is needed, when they are uploaded to the `[print$]` share with the help of the APW or `rpcclient`.

The generation and setting of a first valid Device Mode however requires some "tickling" from a client, to set it on the Samba server. The easiest means of doing so is to simply change the page orientation on the server's printer. This "executes" enough of the printer driver program on the client for the desired effect to happen, and feeds back the new Device Mode to our Samba server. You can use the native Windows NT/2K/XP printer properties page from a Window client for this:

- Browse the **Network Neighbourhood**
- Find the Samba server
- Open the Samba server's **Printers and Faxes** folder
- Highlight the shared printer in question
- Right-click the printer (you may already be here, if you followed the last section's description)
- At the bottom of the context menu select **Properties...** (if the menu still offers the **Connect...** entry further above, you need to click that one first to achieve the driver installation as shown in the last section)
- Go to the **Advanced** tab; click on **Printing Defaults...**
- Change the "Portrait" page setting to "Landscape" (and back)
- (Oh, and make sure to *apply* changes between swapping the page orientation to cause the change to actually take effect...).
- While you're at it, you may optionally also want to set the desired printing defaults here, which then apply to all future client driver installations on the remaining from now on.

This procedure has executed the printer driver program on the client platform and fed back the correct Device Mode to Samba, which now stored it in its TDB files. Once the driver is installed on the client, you can follow the analogous steps by

accessing the *local* **Printers** folder too if you are a Samba printer admin user. From now on printing should work as expected.

Samba also includes a service level parameter name `default devmode` for generating a default Device Mode for a printer. Some drivers will function well with Samba's default set of properties. Others may crash the client's spooler service. So use this parameter with caution. It is always better to have the client generate a valid device mode for the printer and store it on the server for you.

18.8.3. Further Client Driver Install Procedures

Every further driver may be done by any user, along the lines described above: Browse network, open printers folder on Samba server, right-click printer and choose **Connect....** Once this completes (should be not more than a few seconds, but could also take a minute, depending on network conditions), you should find the new printer in your client workstation local **Printers and Faxes** folder.

You can also open your local **Printers and Faxes** folder by using this command on Windows 2000 and Windows XP Professional workstations:

```
rundll32 shell32.dll,SHHelpShortcuts_RunDLL PrintersFolder
```

or this command on Windows NT 4.0 workstations:

```
rundll32 shell32.dll,Control_RunDLL MAIN.CPL @2
```

You can enter the commands either inside a **DOS box** window or in the **Run command...** field from the **Start** menu.

18.8.4. Always make first Client Connection as root or "printer admin"

After you installed the driver on the Samba server (in its `[print$]` share, you should always make sure that your first client installation completes correctly. Make it a habit for yourself to build that the very first connection from a client as printer admin. This is to make sure that:

- a first valid *Device Mode* is really initialized (see above for more explanation details), and that
- the default print settings of your printer for all further client installations are as you want them

Do this by changing the orientation to landscape, click *Apply*, and then change it back again. Then modify the other settings (for example, you don't want the default media size set to *Letter*, when you are all using *A4*, right? You may want to set the printer for *duplex* as the default; etc.).

To connect as root to a Samba printer, try this command from a Windows 2K/XP DOS box command prompt:

```
runas /netonly /user:root "rundll32 printui.dll,PrintUIEntry /p /t3 /n \\SAMBA-SERVER\printer"
```

You will be prompted for root's Samba-password; type it, wait a few seconds, click on **Printing Defaults...** and proceed to set the job options as should be used as defaults by all clients. Alternatively, instead of root you can name one other member of the printer admins from the setting.

Now all the other users downloading and installing the driver the same way (called *Point'n'Print*) will have the same defaults set for them. If you miss this step you'll get a lot of helpdesk calls from your users. But maybe you like to talk to people.... ;-)

18.9. Other Gotchas

Your driver is installed. It is ready for *Point'n'Print* installation by the clients now. You *may* have tried to download and use it onto your first client machine now. But wait... let's make you acquainted first with a few tips and tricks you may find useful. For example, suppose you didn't manage to "set the defaults" on the printer, as advised in the preceding paragraphs? And your users complain about various issues (such as 'We need to set the paper size for each job from Letter to A4 and it won't store it!')

18.9.1. Setting Default Print Options for the Client Drivers

The last sentence might be viewed with mixed feelings by some users and admins. They have struggled for hours and hours and couldn't arrive at a point where their settings seemed to be saved. It is not their fault. The confusing thing is this: in the multi-tabbed dialog that pops up when you right-click the printer name and select **Properties...**, you can arrive at two identically looking dialogs, each claiming that they help you to set printer options, in three different ways. Here is the definite answer to the "Samba Default Driver Setting FAQ":

I can't set and save default print options for all users on Win2K/XP! Why not? How are you doing it? I bet the wrong way.... (it is not very easy to find out, though). There are 3 different ways to bring you to a dialog that *seems* to set everything. All three dialogs *look* the same. Only one of them *does* what you intend. *Important:* you need to be Administrator or Print Administrator to do this for all users. Here is how I reproduce it in on XP Professional:

A The first "wrong" way:

- 1 Open the **Printers** folder.
- 2 Right-click on the printer (*remoteprinter on cupshost*) and select in context menu **Printing Preferences...**
- 3 Look at this dialog closely and remember what it looks like.

B The second "wrong" way:

- 1 Open the **Printers** folder.
- 2 Right-click on the printer (*remoteprinter on cupshost*) and select in the context menu **Properties**
- 3 Click on the **General** tab
- 4 Click on the button **Printing Preferences...**
- 5 A new dialog opens. Keep this dialog open and go back to the parent dialog.

C The third, the "correct" way: (should you do this from the beginning, just carry out steps 1. and 2. from second "way" above)

- 1 Click on the **Advanced** tab. (Hmmm... if everything is "Grayed Out", then you are not logged in as a user with enough privileges).
- 2 Click on the **Printing Defaults...** button.
- 3 On any of the two new tabs, click on the **Advanced...** button.
- 4 A new dialog opens. Compare this one to the other, identical looking one from "B.5" or A.3".

Do you see any difference in the two settings dialogs? I don't either. However, only the last one, which you arrived at with steps C.1.-6. will permanently save any settings which will then become the defaults for new users. If you want all clients to have the same defaults, you need to conduct these steps as administrator (printer admin in) *before* a client downloads the driver (the clients can later set their own *per-user defaults* by following the procedures A. or B. above...). (This is new: Windows

2000 and Windows XP allow *per-user* default settings and the ones the administrator gives them, before they set up their own). The "parents" of the identically looking dialogs have a slight difference in their window names: one is called **Default Print Values for Printer Foo on Server Bar**" (which is the one you need) and the other is called "Print Settings for Printer Foo on Server Bar". The last one is the one you arrive at when you right-click on the printer and select **Print Settings...** This is the one what you were taught to use back in the days of Windows NT! So it is only natural to try the same way with Win2k or WinXP. You wouldn't dream that there is now a different "clicking path" to arrive at an identically looking, but functionally different dialog to set defaults for all users!

TIP

Try (on Win2000 and WinXP) to run this command (as a user with the right privileges):

```
rundll32      printui.dll,PrintUIEntry      /p      /t3
/n\\SAMBASERVER\printersharename
```



to see the tab with the **Printing Defaults...** button (the one you need). Also run this command:

```
rundll32      printui.dll,PrintUIEntry      /p      /t0
/n\\SAMBASERVER\printersharename
```

to see the tab with the **Printing Preferences...** button (the one which doesn't set system-wide defaults). You can start the commands from inside a DOS box" or from the **Start – Run...** menu.

18.9.2. Supporting large Numbers of Printers

One issue that has arisen during the recent development phase of Samba is the need to support driver downloads for 100's of printers. Using Windows NT APW here is somewhat awkward (to say the least). If you don't want to acquire RSS pains from such the printer installation clicking orgy alone, you need to think about a non-interactive script.

If more than one printer is using the same driver, the **rpcclient setdriver** command can be used to set the driver associated with an installed queue. If the driver is uploaded to [print\$] once and registered with the printing TDBs, it can be used by multiple print queues. In this case you just need to repeat the **setprinter** subcommand of **rpcclient** for every queue (without the need to conduct the **adddriver** again and again). The following is an example of how this could be accomplished:

```
root# rpcclient SAMBA-CUPS -U root%secret -c 'enumdrivers'
cmd = enumdrivers
```

```
[Windows NT x86]
```

```
Printer Driver Info 1:
```

```
Driver Name: [infotec IS 2075 PCL 6]
```

```
Printer Driver Info 1:
```

```
Driver Name: [DANKA InfoStream]

Printer Driver Info 1:
  Driver Name: [Heidelberg Digimaster 9110 (PS)]

Printer Driver Info 1:
  Driver Name: [dm9110]

Printer Driver Info 1:
  Driver Name: [myphantasydrivername]

[....]

root# rpcclient SAMBA-CUPS -U root%secret -c 'enumprinters'
cmd = enumprinters
  flags:[0x800000]
  name:[\\SAMBA-CUPS\dm9110]
  description:[\\SAMBA-CUPS\dm9110,,110ppm HiVolume DANKA Stuttgart]
  comment:[110 ppm HiVolume DANKA Stuttgart]
[....]

root# rpcclient SAMBA-CUPS -U root%secret -c 'setdriver dm9110 "Heidelberg Digimaster
cmd = setdriver dm9110 Heidelberg Digimaster 9110 (PPD)
Successfully set dm9110 to driver Heidelberg Digimaster 9110 (PS).

root# rpcclient SAMBA-CUPS -U root%secret -c 'enumprinters'
cmd = enumprinters
  flags:[0x800000]
  name:[\\SAMBA-CUPS\dm9110]
  description:[\\SAMBA-CUPS\dm9110,Heidelberg Digimaster 9110 (PS),110ppm HiVolume
  comment:[110ppm HiVolume DANKA Stuttgart]
[....]

root# rpcclient SAMBA-CUPS -U root%secret -c 'setdriver dm9110 myphantasydrivername'
cmd = setdriver dm9110 myphantasydrivername
Successfully set dm9110 to myphantasydrivername.

root# rpcclient SAMBA-CUPS -U root%secret -c 'enumprinters'
cmd = enumprinters
  flags:[0x800000]
  name:[\\SAMBA-CUPS\dm9110]
  description:[\\SAMBA-CUPS\dm9110,myphantasydrivername,110ppm HiVolume DANKA Stuttg
  comment:[110ppm HiVolume DANKA Stuttgart]
[....]
```

It may be not easy to recognize: but the first call to **enumprinters** showed the

”dm9110” printer with an empty string where the driver should have been listed (between the 2 commas in the ”description” field). After the **setdriver** command succeeded, all is well. (The CUPS Printing chapter has more info about the installation of printer drivers with the help of **rpcclient**).

18.9.3. Adding new Printers with the Windows NT APW

By default, Samba exhibits all printer shares defined in `smb.conf` in the **Printers...** folder. Also located in this folder is the Windows NT Add Printer Wizard icon. The APW will be shown only if:

- ...the connected user is able to successfully execute an **OpenPrinterEx(\\server)** with administrative privileges (i.e. root or printer admin).

TIP



Try this from a Windows 2K/XP DOS box command prompt:

```
runas /netonly /user:root rundll32 printui.dll,PrintUIEntry  
/p /t0 /n \\SAMBA-SERVER\printersharename
```

and click on **Printing Preferences...**

- ... contains the setting `show add printer wizard = yes` (the default).

The APW can do various things:

- upload a new driver to the Samba `[print$]` share;
- associate an uploaded driver with an existing (but still ”driverless”) print queue;
- exchange the currently used driver for an existing print queue with one that has been uploaded before;
- add an entirely new printer to the Samba host (only in conjunction with a working add printer command; a corresponding delete printer command for removing entries from the **Printers...** folder may be provided too)

The last one (add a new printer) requires more effort than the previous ones. In order to use the APW to successfully add a printer to a Samba server, the add printer command must have a defined value. The program hook must successfully add the printer to the Unix print system (i.e. to `/etc/printcap`, `/etc/cups/printers.conf` or other appropriate files) and to if necessary.

When using the APW from a client, if the named printer share does not exist, `smbd` will execute the add printer command and reparse to the to attempt to locate the new printer share. If the share is still not defined, an error of Access Denied is returned to the client. Note that the add printer command is executed under the context of the connected user, not necessarily a root account. A map to guest = bad user may have connected you unwittingly under the wrong privilege; you should check it by using the **smbstatus** command.

18.9.4. Weird Error Message Cannot connect under a different Name

Once you are connected with the wrong credentials, there is no means to reverse the situation other than to close all Explorer windows, and perhaps reboot.

- The `net use \\SAMBA-SERVER\sharename /user:root` gives you an error message: Multiple connections to a server or a shared resource by the same user utilizing the several user names are not allowed. Disconnect all previous connections to the server, resp. the shared resource, and try again.
- Every attempt to "connect a network drive" to `\\SAMBASERVER\print$` to `z:` is countered by the pertinacious message. This network folder is currently connected under different credentials (username and password). Disconnect first any existing connection to this network share in order to connect again under a different username and password.

So you close all connections. You try again. You get the same message. You check from the Samba side, using `smbstatus`. Yes, there are some more connections. You kill them all. The client still gives you the same error message. You watch the `smbd.log` file on a very high debug level and try re-connect. Same error message, but not a single line in the log. You start to wonder if there was a connection attempt at all. You run `ethereal` and `tcpdump` while you try to connect. Result: not a single byte goes on the wire. Windows still gives the error message. You close all Explorer Windows and start it again. You try to connect - and this times it works! Windows seems to cache connection info somewhere and doesn't keep it up to date (if you are unlucky you might need to reboot to get rid of the error message).

18.9.5. Be careful when assembling Driver Files

You need to be very careful when you take notes about the files and belonging to a particular driver. Don't confuse the files for driver version "0" (for Win95/98/ME, going into `[print$]/WIN/0/`), driver version "2" (Kernel Mode driver for WinNT, going into `[print$]/W32X86/2/` *may* be used on Win2K/XP too), and driver version "3" (non-Kernel Mode driver going into `[print$]/W32X86/3/` *can not* be used on WinNT). Very often these different driver versions contain files carrying the same name; but still the files are very different! Also, if you look at them from the Windows Explorer (they reside in `%WINDOWS%\system32\spool\drivers\W32X86\`) you will probably see names in capital letters, while an "enumdrivers" command from Samba would show mixed or lower case letters. So it is easy to confuse them. If you install them manually using `rpcclient` and subcommands, you may even succeed without an error message. Only later, when you try install on a client, you will encounter error messages like `This server has no appropriate driver for the printer`.

Here is an example. You are invited to look very closely at the various files, compare their names and their spelling, and discover the differences in the composition of the version-2 and -3 sets Note: the version-0 set contained 40 (!) `Dependentfiles`, so I left it out for space reasons:

```
root# rpcclient -U 'Administrator%secret' -c 'enumdrivers 3' 10.160.50.8
```

```
Printer Driver Info 3:
  Version: [3]
  Driver Name: [Canon iR8500 PS3]
  Architecture: [Windows NT x86]
  Driver Path: [\\10.160.50.8\print$\W32X86\3\cns3g.dll]
  Datafile: [\\10.160.50.8\print$\W32X86\3\iR8500sg.xpd]
  Configfile: [\\10.160.50.8\print$\W32X86\3\cns3gui.dll]
  Helpfile: [\\10.160.50.8\print$\W32X86\3\cns3g.hlp]
```

```
Dependentfiles: [\\10.160.50.8\print$\W32X86\3\aucplmNT.dll]
Dependentfiles: [\\10.160.50.8\print$\W32X86\3\ucs32p.dll]
Dependentfiles: [\\10.160.50.8\print$\W32X86\3\tnl32.dll]
Dependentfiles: [\\10.160.50.8\print$\W32X86\3\aussdrv.dll]
Dependentfiles: [\\10.160.50.8\print$\W32X86\3\cnspsc.dll]
Dependentfiles: [\\10.160.50.8\print$\W32X86\3\aussapi.dat]
Dependentfiles: [\\10.160.50.8\print$\W32X86\3\cns3407.dll]
Dependentfiles: [\\10.160.50.8\print$\W32X86\3\CnS3G.cnt]
Dependentfiles: [\\10.160.50.8\print$\W32X86\3\NBAPI.DLL]
Dependentfiles: [\\10.160.50.8\print$\W32X86\3\NBIPC.DLL]
Dependentfiles: [\\10.160.50.8\print$\W32X86\3\cpcview.exe]
Dependentfiles: [\\10.160.50.8\print$\W32X86\3\cpcdsp1.exe]
Dependentfiles: [\\10.160.50.8\print$\W32X86\3\cpcedit.dll]
Dependentfiles: [\\10.160.50.8\print$\W32X86\3\cpcqm.exe]
Dependentfiles: [\\10.160.50.8\print$\W32X86\3\cpcspl.dll]
Dependentfiles: [\\10.160.50.8\print$\W32X86\3\cfine32.dll]
Dependentfiles: [\\10.160.50.8\print$\W32X86\3\cpcr407.dll]
Dependentfiles: [\\10.160.50.8\print$\W32X86\3\Cpcqm407.hlp]
Dependentfiles: [\\10.160.50.8\print$\W32X86\3\cpcqm407.cnt]
Dependentfiles: [\\10.160.50.8\print$\W32X86\3\cns3ggr.dll]
```

```
Monitorname: []
Defaultdatatype: []
```

Printer Driver Info 3:

```
Version: [2]
Driver Name: [Canon iR5000-6000 PS3]
Architecture: [Windows NT x86]
Driver Path: [\\10.160.50.8\print$\W32X86\2\cns3g.dll]
Datafile: [\\10.160.50.8\print$\W32X86\2\IR5000sg.xpd]
Configfile: [\\10.160.50.8\print$\W32X86\2\cns3gui.dll]
Helpfile: [\\10.160.50.8\print$\W32X86\2\cns3g.hlp]
```

```
Dependentfiles: [\\10.160.50.8\print$\W32X86\2\AUCPLMNT.DLL]
Dependentfiles: [\\10.160.50.8\print$\W32X86\2\aussdrv.dll]
Dependentfiles: [\\10.160.50.8\print$\W32X86\2\cnspsc.dll]
Dependentfiles: [\\10.160.50.8\print$\W32X86\2\aussapi.dat]
Dependentfiles: [\\10.160.50.8\print$\W32X86\2\cns3407.dll]
Dependentfiles: [\\10.160.50.8\print$\W32X86\2\CnS3G.cnt]
Dependentfiles: [\\10.160.50.8\print$\W32X86\2\NBAPI.DLL]
Dependentfiles: [\\10.160.50.8\print$\W32X86\2\NBIPC.DLL]
Dependentfiles: [\\10.160.50.8\print$\W32X86\2\cns3gum.dll]
```

```
Monitorname: [CPCA Language Monitor2]
Defaultdatatype: []
```

If we write the "version 2" files and the "version 3" files into different text files and compare the result, we see this picture:

```
root# sdiff 2-files 3-files
```



```

cns3g.dll          cns3g.dll
iR8500sg.xpd      iR8500sg.xpd
cns3gui.dll       cns3gui.dll
cns3g.hlp         cns3g.hlp
AUCPLMNT.DLL     | aucplmNT.dll
                  > ucs32p.dll
                  > tnl32.dll

aussdrv.dll       aussdrv.dll
cnspsc.dll        cnspsc.dll
aussapi.dat       aussapi.dat
cns3407.dll       cns3407.dll
CnS3G.cnt         CnS3G.cnt
NBAPI.DLL         NBAPI.DLL
NBIPC.DLL         NBIPC.DLL
cns3gum.dll       | cpcview.exe
                  > cpcdspl.exe
                  > cpcqm.exe
                  > cpcspl.dll
                  > cfine32.dll
                  > cpcr407.dll
                  > Cpcqm407.hlp
                  > cpcqm407.cnt
                  > cns3ggr.dll

```

Don't be fooled though! Driver files for each version with identical names may be different in their content, as you can see from this size comparison:

```

root# for i in cns3g.hlp cns3gui.dll cns3g.dll; do          \
    smbclient //10.160.50.8/print/$ -U 'Administrator%xxxx' \
    -c "cd W32X86/3; dir $i; cd .. ; cd 2; dir $i";          \
done

```

```

CNS3G.HLP          A    122981  Thu May 30 02:31:00 2002
CNS3G.HLP          A     99948  Thu May 30 02:31:00 2002

CNS3GUI.DLL        A   1805824  Thu May 30 02:31:00 2002
CNS3GUI.DLL        A   1785344  Thu May 30 02:31:00 2002

CNS3G.DLL          A   1145088  Thu May 30 02:31:00 2002
CNS3G.DLL          A    15872   Thu May 30 02:31:00 2002

```

In my example were even more differences than shown here. Conclusion: you must be very careful to select the correct driver files for each driver version. Don't rely on the names alone. Don't interchange files belonging to different driver versions.

18.9.6. Samba and Printer Ports

Windows NT/2000 print servers associate a port with each printer. These normally take the form of LPT1:, COM1:, FILE:, etc. Samba must also support the concept of ports associated with a printer. By default, only one printer port, named "Samba Printer Port", exists on a system. Samba does not really need such a "port" in order to print; it rather is a requirement of Windows clients. They insist on being told about an available port when they request this info, otherwise they throw an error message at you. So Samba fakes the port information to keep the Windows clients happy.

Note that Samba does not support the concept of "Printer Pooling" internally either. Printer Pooling assigns a logical printer to multiple ports as a form of load balancing or fail over.

If you require that multiple ports be defined for some reason or another ('My users and my Boss should not know that they are working with Samba'), possesses a `enumports` command which can be used to define an external program that generates a listing of ports on a system.

18.9.7. Avoiding the most common Misconfigurations of the Client Driver

So - printing works, but there are still problems. Most jobs print well, some don't print at all. Some jobs have problems with fonts, which don't look good at all. Some jobs print fast, and some are dead-slow. We can't cover it all; but we want to encourage you to read the little paragraph about "Avoiding the wrong PostScript Driver Settings" in the CUPS Printing part of this document.

18.10. The Imprints Toolset

The Imprints tool set provides a UNIX equivalent of the Windows NT Add Printer Wizard. For complete information, please refer to the Imprints web site at <http://imprints.sourceforge.net/> as well as the documentation included with the imprints source distribution. This section will only provide a brief introduction to the features of Imprints.

Attention! Maintainer required Unfortunately, the Imprints toolset is no longer maintained. As of December, 2000, the project is in need of a new maintainer. The most important skill to have is decent perl coding and an interest in MS-RPC based printing using Samba. If you wish to volunteer, please coordinate your efforts on the samba-technical mailing list. The toolset is still in usable form; but only for a series of older printer models, where there are prepared packages to use. Packages for more up to date print devices are needed if Imprints should have a future.

18.10.1. What is Imprints?

Imprints is a collection of tools for supporting these goals:

- Providing a central repository information regarding Windows NT and 95/98 printer driver packages
- Providing the tools necessary for creating the Imprints printer driver packages.
- Providing an installation client which will obtain printer drivers from a central internet (or intranet) Imprints Server repository and install them on remote Samba and Windows NT4 print servers.

18.10.2. Creating Printer Driver Packages

The process of creating printer driver packages is beyond the scope of this document (refer to `Imprints.txt` also included with the Samba distribution for more information). In short, an Imprints driver package is a gzipped tarball containing the driver files, related INF files, and a control file needed by the installation client.

18.10.3. The Imprints Server

The Imprints server is really a database server that may be queried via standard HTTP mechanisms. Each printer entry in the database has an associated URL for the actual downloading of the package. Each package is digitally signed via GnuPG which can be used to verify that package downloaded is actually the one referred in the Imprints database. It is strongly recommended that this security check *not* be disabled.

18.10.4. The Installation Client

More information regarding the Imprints installation client is available in the `Imprints-Client-HOWTO.ps` file included with the imprints source package.

The Imprints installation client comes in two forms.

- a set of command line Perl scripts
- a GTK+ based graphical interface to the command line Perl scripts

The installation client (in both forms) provides a means of querying the Imprints database server for a matching list of known printer model names as well as a means to download and install the drivers on remote Samba and Windows NT print servers.

The basic installation process is in four steps and perl code is wrapped around `smbclient` and `rpcclient`

- `foreach` (supported architecture for a given driver)
 1. `rpcclient`: Get the appropriate upload directory on the remote server
 2. `smbclient`: Upload the driver files
 3. `rpcclient`: Issues an `AddPrinterDriver()` MS-RPC
- `rpcclient`: Issue an `AddPrinterEx()` MS-RPC to actually create the printer

One of the problems encountered when implementing the Imprints tool set was the name space issues between various supported client architectures. For example, Windows NT includes a driver named "Apple LaserWriter II NTX v51.8" and Windows 95 calls its version of this driver "Apple LaserWriter II NTX"

The problem is how to know what client drivers have been uploaded for a printer. An astute reader will remember that the Windows NT Printer Properties dialog only includes space for one printer driver name. A quick look in the Windows NT 4.0 system registry at

```
HKLM\System\CurrentControlSet\Control\Print\Environment
```

will reveal that Windows NT always uses the NT driver name. This is ok as Windows NT always requires that at least the Windows NT version of the printer driver is present. However, Samba does not have the requirement internally. Therefore, how can you use the NT driver name if it has not already been installed?

The way of sidestepping this limitation is to require that all Imprints printer driver packages include both the Intel Windows NT and 95/98 printer drivers and that NT driver is installed first.

18.11. Add Network Printers at Logon without User Interaction

The following MS Knowledge Base article may be of some help if you need to handle Windows 2000 clients: *How to Add Printers with No User Interaction in Windows 2000*. (<http://support.microsoft.com/default.aspx?scid=kb;en-us;189105>). It also applies to Windows XP Professional clients.

The ideas sketched out below are inspired by this article. It describes a commandline method which can be applied to install network and local printers and their drivers. This is most useful if integrated in Logon Scripts. You can see what options are available by typing in a command prompt ("DOS box") this:

```
rundll32 printui.dll,PrintUIEntry /?
```

A window pops up which shows you all of the commandline switches available. An extensive list of examples is also provided. This is only for Win 2k/XP. It doesn't work on WinNT. WinNT has probably some other tools in the respective Resource Kit. Here is a suggestion about what a client logon script might contain, with a short explanation of what the lines actually do (it works if 2k/XP Windows clients access printers via Samba, but works for Windows-based print servers too):

```
rundll32 printui.dll,PrintUIEntry /dn /n "\\sambacupssserver\infotec2105-IPDS" /q
rundll32 printui.dll,PrintUIEntry /in /n "\\sambacupssserver\infotec2105-PS"
rundll32 printui.dll,PrintUIEntry /y /n "\\sambacupssserver\infotec2105-PS"
```

Here is a list of the used commandline parameters:

```
/dn deletes a network printer
/q quiet modus
/n names a printer
/in adds a network printer connection
/y sets printer as default printer
```

I have tested this with a Samba 2.2.7a and a Samba-3alpha24 installation and Windows XP Professional clients. Note that this specific command set works with network print queues (installing local print queues requires different parameters, but this is of no interest here).

- Line 1 deletes a possibly existing previous network printer *infotec2105-IPDS* (which had used native Windows drivers with LPRng that were removed from the server which was converted to CUPS). The **/q** at the end eliminates "Confirm" or error dialog boxes popping up. They should not be presented to the user logging on.
- Line 2 adds the new printer *infotec2105-PS* (which actually is same physical device but is now run by the new CUPS printing system and associated with the CUPS/Adobe PS drivers). The printer and its driver *must* have been added to Samba prior to the user logging in (e.g. by a procedure as discussed earlier in this chapter, or by running **cupsaddsmb**). The driver is now auto-downloaded to the client PC where the user is about to log in.
- Line 3 sets the default printer to this new network printer (there might be several other printers installed with this same method and some may be local as well – so we decide for a default printer). The default printer selection may of course be different for different users.

Note that the second line only works if the printer *infotec2105-PS* has an already working printqueue on "sambacupssserver", and if the printer drivers have successfully been uploaded (via **APW**, **smbclient/rpcclient** or **cupsaddsmb**) into the [print\$]

driver repository of Samba. Also, some Samba versions prior to version 3.0 required a re-start of `smbd` after the printer install and the driver upload, otherwise the script (or any other client driver download) would fail.

Since there no easy way to test for the existence of an installed network printer from the logon script, the suggestion is: don't bother checking and just allow the de-installation/reinstallation to occur every time a user logs in; it's really quick anyway (1 to 2 seconds).

The additional benefits for this are:

- It puts in place any printer default setup changes automatically at every user logon.
- It allows for "roaming" users' login into the domain from different workstations.

Since network printers are installed per user this much simplifies the process of keeping the installation up-to-date. The extra few seconds at logon time will not really be noticeable. Printers can be centrally added, changed, and deleted at will on the server with no user intervention required on the clients (you just need to keep the logon scripts up to date).

18.12. The `addprinter` command

The `addprinter` command can be configured to be a shell script or program executed by Samba. It is triggered by running the APW from a client against the Samba print server. The APW asks the user to fill in several fields (such as printer name, driver to be used, comment, port monitor, etc.). These parameters are passed on to Samba by the APW. If the `addprinter` command is designed in a way that it can create a new printer (through writing correct `printcap` entries on legacy systems, or execute the `lpadmin` command on more modern systems) and create the associated share in `printers`, then the APW will in effect really create a new printer on Samba and the UNIX print subsystem!

18.13. Migration of "Classical" printing to Samba-3

The basic "NT-style" printer driver management has not changed considerably in 3.0 over the 2.2.x releases (apart from many small improvements). Here migration should be quite easy, especially if you followed previous advice to stop using deprecated parameters in your setup. For migrations from an existing 2.0.x setup, or if you continued "Win9x-style" printing in your Samba 2.2 installations, it is more of an effort. Please read the appropriate release notes and the HOWTO Collection for 2.2. You can follow several paths. Here are possible scenarios for migration:

- You need to study and apply the new Windows NT printer and driver support. Previously used parameters "printer driver file", "printer driver" and "printer driver location" are no longer supported.
- If you want to take advantage of WinNT printer driver support you also need to migrate the Win9x/ME drivers to the new setup.
- An existing `printers.def` file (the one specified in the now removed parameter `printer driver file = ...`) will work no longer with Samba-3.0. In 3.0, `smbd` attempts to locate a Win9x/ME driver files for the printer in `[print$]` and additional settings in the TDB and only there; if it fails it will *not* (as 2.2.x used to do) drop down to using a `printers.def` (and all associated parameters). The `make_printerdef` tool is removed and there is no backwards compatibility for this.

- You need to install a Windows 9x driver into the [print\$] share for a printer on your Samba host. The driver files will be stored in the "WIN40/0" subdirectory of [print\$], and some other settings and info go into the printing-related TDBs.
- If you want to migrate an existing `printers.def` file into the new setup, the current only solution is to use the Windows NT APW to install the NT drivers and the 9x drivers. This can be scripted using `smbclient` and `rpcclient`. See the Imprints installation client at:
<http://imprints.sourceforge.net/>
for an example. See also the discussion of `rpcclient` usage in the "CUPS Printing" section.

18.14. Publishing Printer Information in Active Directory or LDAP

We will publish an update to this section shortly.

18.15. Common Errors and Problems

Here are a few typical errors and problems people have encountered. You can avoid them. Read on.

18.15.1. I give my root password but I don't get access

Don't confuse the root password which is valid for the Unix system (and in most cases stored in the form of a one-way hash in a file named `/etc/shadow`) with the password used to authenticate against Samba!. Samba doesn't know the UNIX password; for root to access Samba resources via Samba-type access, a Samba account for root must be created first. This is often done with the `smbpasswd` command.

18.15.2. My printjobs get spooled into the spooling directory, but then get lost

Don't use the existing Unix print system spool directory for the Samba spool directory. It may seem convenient and a saving of space, but it only leads to problems. The two *must* be separate.

19. CUPS Printing Support in Samba 3.0

19.1. Introduction

19.1.1. Features and Benefits

The Common Unix Print System ([CUPS](#)) has become very popular. All big Linux distributions now ship it as their default printing system. But to many it is still a very mystical tool. Normally it "just works" (TM). People tend to regard it as a sort of "black box", which they don't want to look into, as long as it works OK. But once there is a little problem, they are in trouble to find out where to start debugging it. Also, even the most recent and otherwise excellent printed Samba documentation has only limited attention paid to CUPS printing, leaving out important pieces or even writing plain wrong things about it. This demands rectification. But before you dive into this chapter, make sure that you don't forget to refer to the "Classical Printing" chapter also. It contains a lot of information that is relevant for CUPS too.

CUPS sports quite a few unique and powerful features. While their basic functions may be grasped quite easily, they are also new. Because they are different from other, more traditional printing systems, it is best to try and not apply any prior knowledge about printing upon this new system. Rather try to start understand CUPS from the beginning. This documentation will lead you here to a complete understanding of CUPS, if you study all of the material contained. But lets start with the most basic things first. Maybe this is all you need for now. Then you can skip most of the other paragraphs.

19.1.2. Overview

CUPS is more than just a print spooling system. It is a complete printer management system that complies with the new IPP (*Internet Printing Protocol*). IPP is an industry and IETF (*Internet Engineering Task Force*) standard for network printing. Many of its functions can be managed remotely (or locally) via a web browser (giving you a platform-independent access to the CUPS print server). In addition it has the traditional commandline and several more modern GUI interfaces (GUI interfaces developed by 3rd parties, like KDE's overwhelming [KDEPrint](#)).

CUPS allows creation of "raw" printers (ie: NO print file format translation) as well as "smart" printers (i.e. CUPS does file format conversion as required for the printer). In many ways this gives CUPS similar capabilities to the MS Windows print monitoring system. Of course, if you are a CUPS advocate, you would argue that CUPS is better! In any case, let us now move on to explore how one may configure CUPS for interfacing with MS Windows print clients via Samba.

19.2. Basic Configuration of CUPS support

Printing with CUPS in the most basic `smb.conf` setup in Samba 3.0 (as was true for 2.2.x) only needs two settings: `printing = cups` and `printcap = cups`. CUPS itself doesn't need a `printcap` file anymore. However, the `cupsd.conf` configuration file knows two related directives: they control if such a file should be automatically

created and maintained by CUPS for the convenience of third party applications (example: `Printcap /etc/printcap` and `PrintcapFormat BSD`). These legacy programs often require the existence of `printcap` file containing printer names or they will refuse to print. Make sure CUPS is set to generate and maintain a `printcap`! For details see **man cupsd.conf** and other CUPS-related documentation, like the wealth of documents on your CUPS server itself: <http://localhost:631/documentation.html>.

19.2.1. Linking of `smbd` with `libcups.so`

Samba has a very special relationship to CUPS. The reason is: Samba can be compiled with CUPS library support. Most recent installations have this support enabled, and per default CUPS linking is compiled into `smbd` and other Samba binaries. Of course, you can use CUPS even if Samba is not linked against `libcups.so` – but there are some differences in required or supported configuration then.

If SAMBA is compiled against `libcups`, then `printcap = cups` uses the CUPS API to list printers, submit jobs, query queues, etc. Otherwise it maps to the System V commands with an additional **-oraw** option for printing. On a Linux system, you can use the **ldd** utility to find out details (`ldd` may not be present on other OS platforms, or its function may be embodied by a different command):

```
transmeta:/home/kurt # ldd 'which smbd'
    libssl.so.0.9.6 => /usr/lib/libssl.so.0.9.6 (0x4002d000)
    libcrypto.so.0.9.6 => /usr/lib/libcrypto.so.0.9.6 (0x4005a000)
    libcups.so.2 => /usr/lib/libcups.so.2 (0x40123000)
    [...]
```

The line `libcups.so.2 => /usr/lib/libcups.so.2 (0x40123000)` shows there is CUPS support compiled into this version of Samba. If this is the case, and `printing = cups` is set, then *any otherwise manually set print command in `smb.conf` is ignored*. This is an important point to remember!

TIP



Should you require – for any reason – to set your own print commands, you can still do this by setting `printing = sysv`. However, you'll lose all the benefits from the close CUPS/Samba integration. You are on your own then to manually configure the rest of the printing system commands (most important: `print command`; other commands are `lppause command`, `lpresume command`, `lpq command`, `lprm command`, `queuepause command` and `queue resume command`).

19.2.2. Simple `smb.conf` Settings for CUPS

To summarize, here is the simplest printing-related setup for `smb.conf` to enable basic CUPS support:

```
[global]
```



```
load printers = yes
printing = cups
printcap name = cups

[printers]
comment = All Printers
path = /var/spool/samba
browseable = no
public = yes
guest ok = yes
writable = no
printable = yes
printer admin = root, @ntadmins
```

This is all you need for basic printing setup for CUPS. It will print all Graphic, Text, PDF and PostScript file submitted from Windows clients. However, most of your Windows users would not know how to send these kind of files to print without opening a GUI application. Windows clients tend to have local printer drivers installed. And the GUI application's print buttons start a printer driver. Your users also very rarely send files from the command line. Unlike UNIX clients, they hardly submit graphic, text or PDF formatted files directly to the spooler. They nearly exclusively print from GUI applications, with a "printer driver" hooked in between the applications native format and the print data stream. If the backend printer is not a PostScript device, the print data stream is "binary", sensible only for the target printer. Read on to learn which problem this may cause and how to avoid it.

19.2.3. More complex smb.conf Settings for CUPS

Here is a slightly more complex printing-related setup for `smb.conf`. It enables general CUPS printing support for all printers, but defines one printer share which is set up differently.

```
[global]
printing = cups
printcap name = cups
load printers = yes

[printers]
comment = All Printers
path = /var/spool/samba
public = yes
guest ok = yes
writable = no
printable = yes
printer admin = root, @ntadmins

[special_printer]
comment = A special printer with his own settings
path = /var/spool/samba-special
```

```
printing = sysv
printcap = lpstat
print command = echo "NEW: 'date': printfile %f" >> /tmp/smbprn.log ;\
                  echo "      'date': p-%p s-%s f-%f" >> /tmp/smbprn.log ;\
                  echo "      'date': j-%j J-%J z-%z c-%c" >> /tmp/smbprn.log
                  rm %f

public = no
guest ok = no
writeable = no
printable = yes
printer admin = kurt
hosts deny = 0.0.0.0
hosts allow = turbo_xp, 10.160.50.23, 10.160.51.60
```

This special share is only there for my testing purposes. It doesn't even write the printjob to a file. It just logs the job parameters known to Samba into the `/tmp/smbprn.log` file and deletes the jobfile. Moreover, the printer admin of this share is "kurt" (not the "@ntadmins" group); guest access is not allowed; the share isn't announced in Network Neighbourhood (so you need to know it is there), and it is only allowing access from three hosts. To prevent CUPS kicking in and taking over the print jobs for that share, we need to set `printing = sysv` and `printcap = lpstat`.

19.3. Advanced Configuration

Before we dive into all the configuration options, let's clarify a few points. *Network printing needs to be organized and setup correctly.* Often this is not done correctly. Legacy systems or small LANs in business environments often lack a clear design and good housekeeping.

19.3.1. Central spooling vs. "Peer-to-Peer" printing

Many small office or home networks, as well as badly organized larger environments, allow each client a direct access to available network printers. Generally, this is a bad idea. It often blocks one client's access to the printer when another client's job is printing. It also might freeze the first client's application while it is waiting to get rid of the job. Also, there are frequent complaints about various jobs being printed with their pages mixed with each other. A better concept is the usage of a "print server": it routes all jobs through one central system, which responds immediately, takes jobs from multiple concurrent clients at the same time and in turn transfers them to the printer(s) in the correct order.

19.3.2. CUPS/Samba as a "spooling-only" Print Server; "raw" printing with Vendor Drivers on Windows Clients

Most traditionally configured Unix print servers acting on behalf of Samba's Windows clients represented a really simple setup. Their only task was to manage the "raw" spooling of all jobs handed to them by Samba. This approach meant that the Windows clients were expected to prepare the printjob file in such a way that it became fit to be fed to the printing device. Here a native (vendor-supplied) Windows printer driver for the target device needed to be installed on each and every client.

Of course you can setup CUPS, Samba and your Windows clients in the same, traditional and simple way. When CUPS printers are configured for RAW print-through mode operation it is the responsibility of the Samba client to fully render the print job (file). The file must be sent in a format that is suitable for direct delivery to the printer. Clients need to run the vendor-provided drivers to do this. In this case CUPS will NOT do any print file format conversion work.

19.3.3. Driver Installation Methods on Windows Clients

The printer drivers on the Windows clients may be installed in two functionally different ways:

- manually install the drivers locally on each client, one by one; this yields the old *LanMan* style printing; it uses a `\\sambaserver\printershare` type of connection.
- deposit and prepare the drivers (for later download) on the print server (Samba); this enables the clients to use "Point'n'Print" to get drivers semi-automatically installed the first time they access the printer; with this method NT/2K/XP clients use the *SPOOLSS/MS-RPC* type printing calls.

The second method is recommended for use over the first.

19.3.4. Explicitly enable "raw" printing for application/octet-stream!

If you use the first option (drivers are installed on the client side), there is one setting to take care of: CUPS needs to be told that it should allow "raw" printing of deliberate (binary) file formats. The CUPS files that need to be correctly set for RAW mode printers to work are:

- `/etc/cups/mime.types`
- `/etc/cups/mime.convs`

Both contain entries (at the end of the respective files) which must be uncommented to allow RAW mode operation. In `/etc/cups/mime.types` make sure this line is present:

```
application/octet-stream
```

In `/etc/cups/mime.convs`, have this line:

```
application/octet-stream  application/vnd.cups-raw  0  -
```

If these two files are not set up correctly for raw Windows client printing, you may encounter the dreaded `Unable to convert file 0` in your CUPS `error_log` file.

NOTE



editing the `mime.convs` and the `mime.types` file does not *enforce* "raw" printing, it only *allows* it.

Background CUPS being a more security-aware printing system than traditional ones does not by default allow a user to send deliberate (possibly binary) data to printing devices. This could be easily abused to launch a "Denial of Service" attack on your printer(s), causing at the least the loss of a lot of paper and ink. "Unknown" data are tagged by CUPS as *MIME type: application/octet-stream* and not allowed to go to the printer. By default, you can only send other (known) MIME types "raw". Sending data "raw" means that CUPS does not try to convert them and passes them to the printer untouched (see next chapter for even more background explanations).

This is all you need to know to get the CUPS/Samba combo printing "raw" files prepared by Windows clients, which have vendor drivers locally installed. If you are not interested in background information about more advanced CUPS/Samba printing, simply skip the remaining sections of this chapter.

19.3.5. Three familiar Methods for driver upload plus a new one

If you want to use the MS-RPC type printing, you must upload the drivers onto the Samba server first ([print\$] share). For a discussion on how to deposit printer drivers on the Samba host (so that the Windows clients can download and use them via "Point'n'Print") please also refer to the previous chapter of this HOWTO Collection. There you will find a description or reference to three methods of preparing the client drivers on the Samba server:

- the GUI, "Add Printer Wizard" *upload-from-a-Windows-client* method;
- the commandline, "smbclient/rpcclient" *upload-from-a-UNIX-workstation* method;
- the *Imprints* Toolset method.

These 3 methods apply to CUPS all the same. A new and more convenient way to load the Windows drivers into Samba is provided provided if you use CUPS:

- the *cupsaddsmb* utility.

cupsaddsmb is discussed in much detail further below. But we will first explore the CUPS filtering system and compare the Windows and UNIX printing architectures.

19.4. Using CUPS/Samba in an advanced Way – intelligent printing with PostScript Driver Download

Still reading on? Good. Let's go into more detail then. We now know how to set up a "dump" printserver, that is, a server which is spooling printjobs "raw", leaving the print data untouched.

Possibly you need to setup CUPS in a more smart way. The reasons could be manifold:

- Maybe your boss wants to get monthly statistics: Which printer did how many pages? What was the average data size of a job? What was the average print run per day? What are the typical hourly peaks in printing? Which departments prints how much?
- Maybe you are asked to setup a print quota system: users should not be able to print more jobs, once they have surpassed a given limit per period?
- Maybe your previous network printing setup is a mess and shall be re-organized from a clean beginning?
- Maybe you have experiencing too many "Blue Screens", originating from poorly debugged printer drivers running in NT "kernel mode"?

These goals cannot be achieved by a raw print server. To build a server meeting these requirements, you'll first need to learn about how CUPS works and how you can enable its features.

What follows is the comparison of some fundamental concepts for Windows and Unix printing; then is the time for a description of the CUPS filtering system, how it works and how you can tweak it.

19.4.1. GDI on Windows – PostScript on Unix

Network printing is one of the most complicated and error-prone day-to-day tasks any user or an administrator may encounter. This is true for all OS platforms. And there are reasons for this.

You can't expect for most file formats to just throw them towards printers and they get printed. There needs to be a file format conversion in between. The problem is: there is no common standard for print file formats across all manufacturers and printer types. While *PostScript* (trademark held by Adobe), and to an extent *PCL* (trademark held by HP), have developed into semi-official "standards", by being the most widely used PDLs (*Page Description Languages*), there are still many manufacturers who "roll their own" (their reasons may be unacceptable license fees for using printer-embedded PostScript interpreters, etc.).

19.4.2. Windows Drivers, GDI and EMF

In Windows OS, the format conversion job is done by the printer drivers. On MS Windows OS platforms all application programmers have at their disposal a built-in API, the GDI (*Graphical Device Interface*), as part and parcel of the OS itself, to base themselves on. This GDI core is used as one common unified ground, for all Windows programs, to draw pictures, fonts and documents *on screen* as well as *on paper* (=print). Therefore printer driver developers can standardize on a well-defined GDI output for their own driver input. Achieving WYSIWYG ("What You See Is What You Get") is relatively easy, because the on-screen graphic primitives, as well as the on-paper drawn objects, come from one common source. This source, the GDI, produces often a file format called EMF (*Enhanced MetaFile*). The EMF is processed by the printer driver and converted to the printer-specific file format.

NOTE



To the GDI foundation in MS Windows, Apple has chosen to put paper and screen output on a common foundation for their (BSD-Unix-based, did you know??) Mac OS X and Darwin Operating Systems. Their *Core Graphic Engine* uses a *PDF* derivate for all display work.

19.4.3. Unix Printfile Conversion and GUI Basics

In Unix and Linux, there is no comparable layer built into the OS kernel(s) or the X (screen display) server. Every application is responsible for itself to create its print output. Fortunately, most use PostScript. That gives at least some common ground. Unfortunately, there are many different levels of quality for this PostScript. And worse: there is a huge difference (and no common root) in the way how the same document is displayed on screen and how it is presented on paper. WYSIWYG

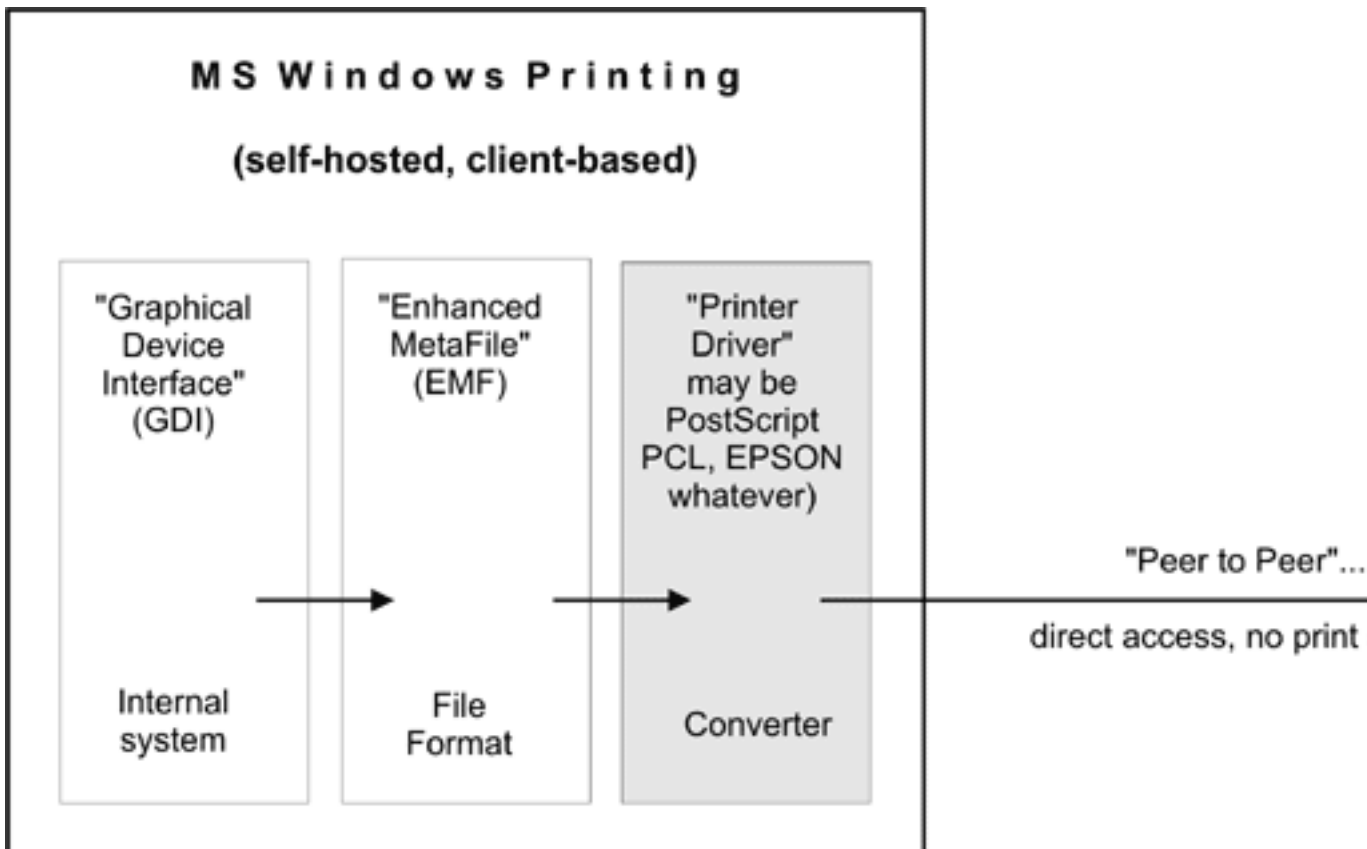

(a)

Figure 19.1: Windows Printing to a local Printer

is more difficult to achieve. This goes back to the time decades ago, when the predecessors of *X.org*, designing the UNIX foundations and protocols for Graphical User Interfaces refused to take over responsibility for "paper output" also, as some had demanded at the time, and restricted itself to "on-screen only". (For some years now, the "Xprint" project has been under development, attempting to build printing support into the X framework, including a PostScript and a PCL driver, but it is not yet ready for prime time.) You can see this unfavorable inheritance up to the present day by looking into the various "font" directories on your system; there are separate ones for fonts used for X display and fonts to be used on paper.

Background The PostScript programming language is an "invention" by Adobe Inc., but its specifications have been published to the full. Its strength lies in its powerful abilities to describe graphical objects (fonts, shapes, patterns, lines, curves, dots...), their attributes (color, linewidth...) and the way to manipulate (scale, distort, rotate, shift...) them. Because of its open specification, anybody with the skill can start writing his own implementation of a PostScript interpreter and use it to display PostScript files on screen or on paper. Most graphical output devices are based on the concept of "raster images" or "pixels" (one notable exception are pen plotters). Of course, you can look at a PostScript file in its textual form and you will be reading its PostScript code, the language instructions which need to be interpreted by a rasterizer. Rasterizers produce pixel images, which may be displayed on screen by a viewer program or on paper by a printer.

19.4.4. PostScript and Ghostscript

So, Unix is lacking a common ground for printing on paper and displaying on screen. Despite this unfavorable legacy for Unix, basic printing is fairly easy: if you have PostScript printers at your disposal! The reason is: these devices have a built-in PostScript language "interpreter", also called a *Raster Image Processor* (RIP), (which makes them more expensive than other types of printers); throw PostScript towards them, and they will spit out your printed pages. Their RIP is doing all the hard work of converting the PostScript drawing commands into a bitmap picture as you see it on paper, in a resolution as done by your printer. This is no different to PostScript printing of a file from a Windows origin.

NOTE



Traditional Unix programs and printing systems – while using PostScript – are largely not PPD-aware. PPDs are "PostScript Printer Description" files. They enable you to specify and control all options a printer supports: duplexing, stapling, punching... Therefore Unix users for a long time couldn't choose many of the supported device and job options, unlike Windows or Apple users. But now there is CUPS.... ;-)

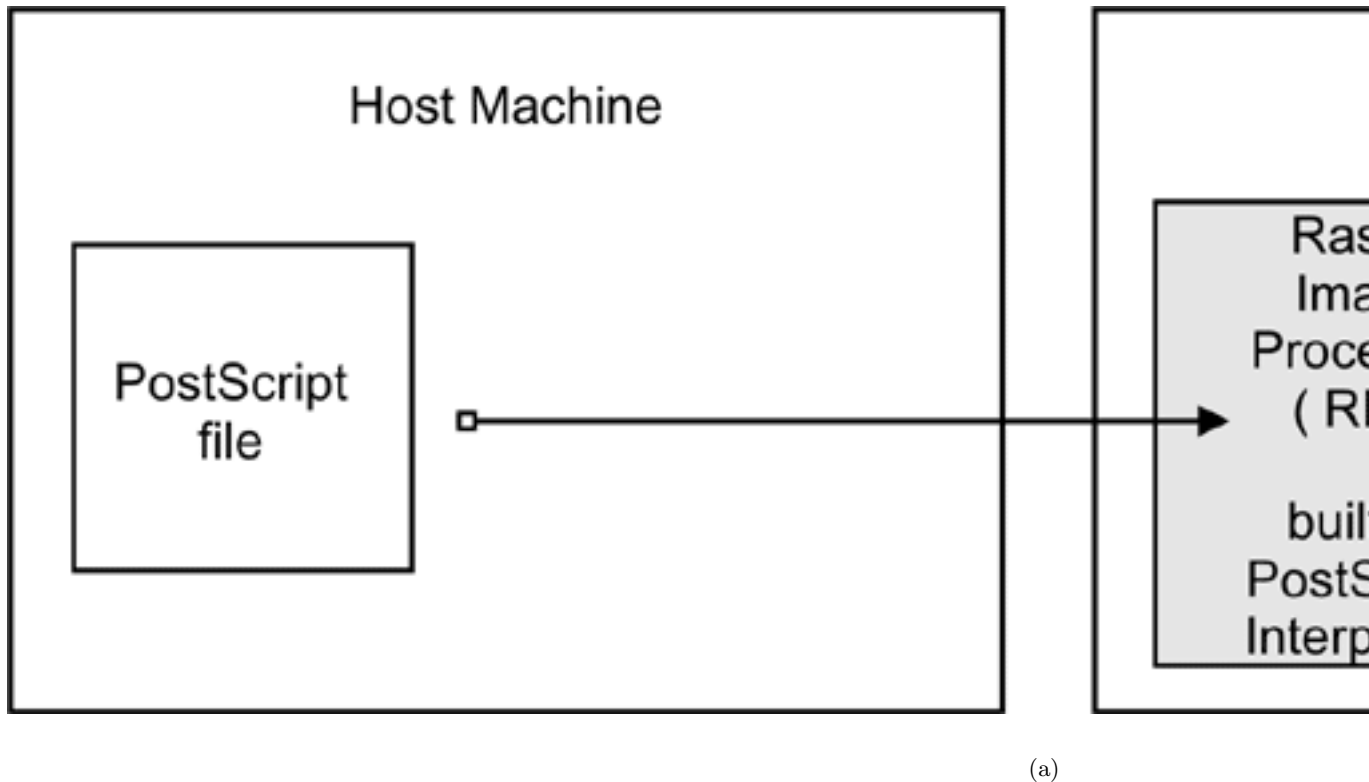

Figure 19.2: Printing to a Postscript Printer

However, there are other types of printers out there. These don't know how to print PostScript. They use their own *Page Description Language* (PDL, often proprietary).

To print to them is much more demanding. Since your Unix applications mostly produce PostScript, and since these devices don't understand PostScript, you need to convert the printfiles to a format suitable for your printer on the host, before you can send it away.

19.4.5. Ghostscript – the Software RIP for non-PostScript Printers

Here is where *Ghostscript* kicks in. Ghostscript is the traditional (and quite powerful) PostScript interpreter used on Unix platforms. It is a RIP in software, capable to do a *lot* of file format conversions, for a very broad spectrum of hardware devices as well as software file formats. Ghostscript technology and drivers is what enables PostScript printing to non-PostScript hardware.

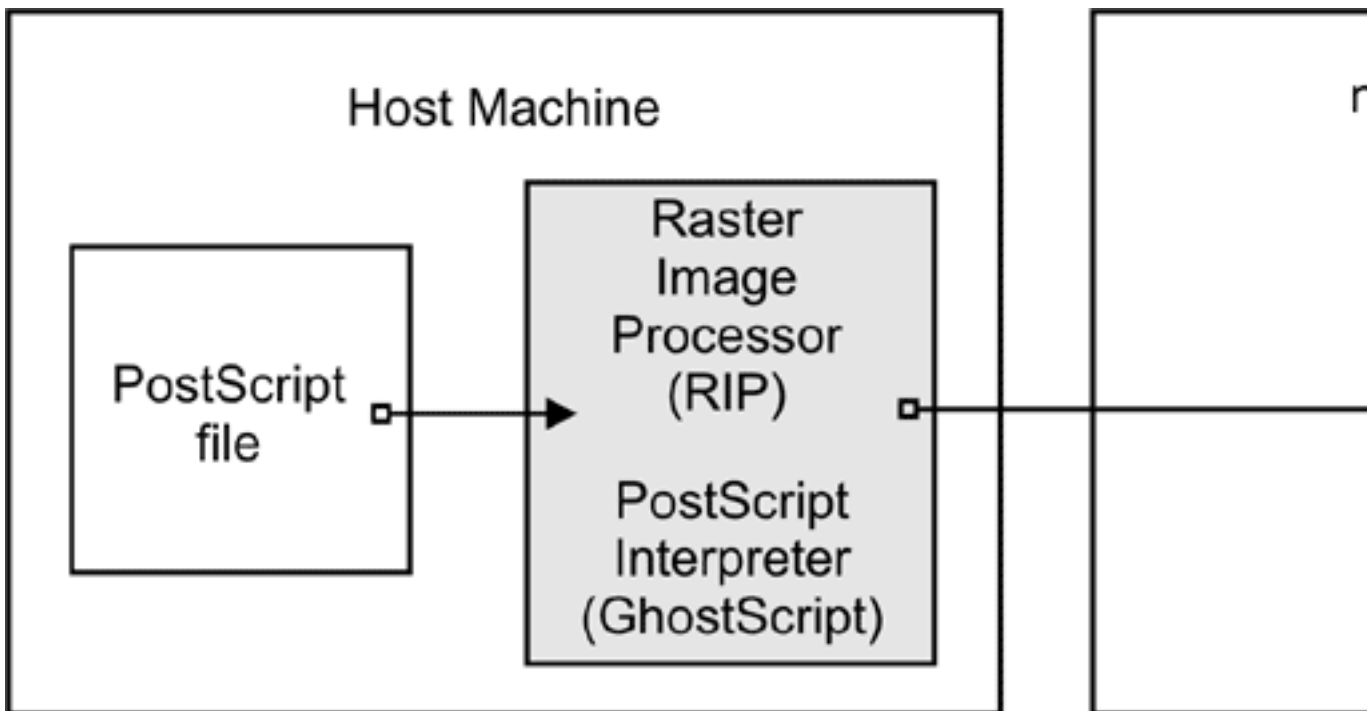

(a)

Figure 19.3: Ghostscript as a RIP for non-postscript printers

TIP



Use the "gs -h" command to check for all built-in "devices" of your Ghostscript version. If you specify e.g. a parameter of -sDEVICE=png256 on your Ghostscript command line, you are asking Ghostscript to convert the input into a PNG file. Naming a "device" on the commandline is the most important single parameter to tell Ghostscript how exactly it should render the input. New Ghostscript versions are released at fairly regular intervals, now by artofcode LLC. They are initially put under the "AFPL" license, but re-released under the GNU GPL as soon as the next AFPL version appears. GNU Ghostscript is probably the version installed on most Samba systems. But it has got some deficiencies. Therefore ESP Ghostscript was developed as an enhancement over GNU Ghostscript, with lots of bug-fixes, additional devices and improvements. It is jointly maintained by developers from CUPS, Gimp-Print, MandrakeSoft, SuSE, RedHat and Debian. It includes the "cups" device (essential to print to non-PS printers from CUPS).

19.4.6. PostScript Printer Description (PPD) Specification

While PostScript in essence is a *Page Description Language* (PDL) to represent the page layout in a *device independent* way, real world print jobs are always ending up to be output on a hardware with device-specific features. To take care of all the differences in hardware, and to allow for innovations, Adobe has specified a syntax and file format for *PostScript Printer Description* (PPD) files. Every PostScript printer ships with one of these files.

PPDs contain all information about general and special features of the given printer model: Which different resolutions can it handle? Does it have a Duplexing Unit? How many paper trays are there? What media types and sizes does it take? For each item it also names the special command string to be sent to the printer (mostly inside the PostScript file) in order to enable it.

Information from these PPDs is meant to be taken into account by the printer drivers. Therefore, installed as part of the Windows PostScript driver for a given printer is the printer's PPD. Where it makes sense, the PPD features are presented in the drivers' UI dialogs to display to the user as choice of print options. In the end, the user selections are somehow written (in the form of special PostScript, PJI, JCL or vendor-dependent commands) into the PostScript file created by the driver.

WARNING



A PostScript file that was created to contain device-specific commands for achieving a certain print job output (e.g. duplexed, stapled and punched) on a specific target machine, may not print as expected, or may not be printable at all on other models; it also may not be fit for further processing by software (e.g. by a PDF distilling program).

19.4.7. CUPS can use all Windows-formatted Vendor PPDs

CUPS can handle all spec-compliant PPDs as supplied by the manufacturers for their PostScript models. Even if a Unix/Linux-illiterate vendor might not have mentioned our favorite OS in his manuals and brochures – you can safely trust this: *if you get hold of the Windows NT version of the PPD, you can use it unchanged in CUPS* and thus access the full power of your printer just like a Windows NT user could!

TIP



To check the spec compliance of any PPD online, go to <http://www.cups.org/testppd.php> and upload your PPD. You will see the results displayed immediately. CUPS in all versions after 1.1.19 has a much more strict internal PPD parsing and checking code enabled; in case of printing trouble this online resource should be one of your first pitstops.

WARNING



For real PostScript printers *don't* use the *Foomatic* or *cupsomatic* PPDs from Linuxprinting.org. With these devices the original vendor-provided PPDs are always the first choice!

TIP



If you are looking for an original vendor-provided PPD of a specific device, and you know that an NT4 box (or any other Windows box) on your LAN has the PostScript driver installed, just use `smbclient //NT4-box/print/$ -U username` to access the Windows directory where all printer driver files are stored. First look in the W32X86/2 subdir for the PPD you are seeking.

19.4.8. CUPS also uses PPDs for non-PostScript Printers

CUPS also uses specially crafted PPDs to handle non-PostScript printers. These PPDs are usually not available from the vendors (and no, you can't just take the PPD of a Postscript printer with the same model name and hope it works for the non-PostScript version too). To understand how these PPDs work for non-PS printers we first need to dive deeply into the CUPS filtering and file format conversion architecture. Stay tuned.

19.5. The CUPS Filtering Architecture

The core of the CUPS filtering system is based on *Ghostscript*. In addition to Ghostscript, CUPS uses some other filters of its own. You (or your OS vendor) may have plugged in even more filters. CUPS handles all data file formats under

the label of various *MIME types*. Every incoming printfile is subjected to an initial *auto-typing*. The auto-typing determines its given MIME type. A given MIME type implies zero or more possible filtering chains relevant to the selected target printer. This section discusses how MIME types recognition and conversion rules interact. They are used by CUPS to automatically setup a working filtering chain for any given input data format.

If CUPS rasterizes a PostScript file *natively* to a bitmap, this is done in 2 stages:

- the first stage uses a Ghostscript device named "cups" (this is since version 1.1.15) and produces a generic raster format called "CUPS raster".
- the second stage uses a "raster driver" which converts the generic CUPS raster to a device specific raster.

Make sure your Ghostscript version has the "cups" device compiled in (check with `gs -h — grep cups`). Otherwise you may encounter the dreaded `Unable to convert file 0` in your CUPS `error_log` file. To have "cups" as a device in your Ghostscript, you either need to *patch GNU Ghostscript* and re-compile or use [ESP Ghostscript](#). The superior alternative is ESP Ghostscript: it supports not just CUPS, but 300 other devices too (while GNU Ghostscript supports only about 180). Because of this broad output device support, ESP Ghostscript is the first choice for non-CUPS spoolers too. It is now recommended by [Linuxprinting.org](#) for all spoolers.

CUPS printers may be setup to use *external* rendering paths. One of the most common ones is provided by the *Foomatic/cupsomatic* concept, from [Linuxprinting.org](#). This uses the classical Ghostscript approach, doing everything in one step. It doesn't use the "cups" device, but one of the many others. However, even for Foomatic/cupsomatic usage, best results and broadest printer model support is provided by ESP Ghostscript (more about cupsomatic/Foomatic, particularly the new version called now *foomatic-rip*, follows below).

19.5.1. MIME types and CUPS Filters

CUPS reads the file `/etc/cups/mime.types` (and all other files carrying a `*.types` suffix in the same directory) upon startup. These files contain the MIME type recognition rules which are applied when CUPS runs its auto-typing routines. The rule syntax is explained in the man page for `mime.types` and in the comments section of the `mime.types` file itself. A simple rule reads like this:

```
application/pdf          pdf string(0,%PDF)
```

This means: if a filename has either a `.pdf` suffix, or if the magic string `%PDF` is right at the beginning of the file itself (offset 0 from the start), then it is a PDF file (*application/pdf*). Another rule is this:

```
application/postscript  ai eps ps string(0,%!) string(0,<04>%!)
```

Its meaning: if the filename has one of the suffixes `.ai`, `.eps`, `.ps` or if the file itself starts with one of the strings `%!` or `<04>%!`, it is a generic PostScript file (*application/postscript*).

NOTE



There is a very important difference between two similar MIME type in CUPS: one is *application/postscript*, the other is *application/vnd.cups-postscript*. While *application/postscript* is meant to be device independent (job options for the file are still outside the PS file content, embedded in commandline or environment variables by CUPS), *application/vnd.cups-postscript* may have the job options inserted into the PostScript data itself (were applicable). The transformation of the generic PostScript (*application/postscript*) to the device-specific version (*application/vnd.cups-postscript*) is the responsibility of the CUPS *pstops* filter. *pstops* uses information contained in the PPD to do the transformation.

WARNING



Don't confuse the other mime.types file your system might be using with the one in the `/etc/cups/` directory.

CUPS can handle ASCII text, HP-GL, PDF, PostScript, DVI and a lot of image formats (GIF, PNG, TIFF, JPEG, Photo-CD, SUN-Raster, PNM, PBM, SGI-RGB and some more) and their associated MIME types with its filters.

19.5.2. MIME type Conversion Rules

CUPS reads the file `/etc/cups/mime.convs` (and all other files named with a `*.convs` suffix in the same directory) upon startup. These files contain lines naming an input MIME type, an output MIME type, a format conversion filter which can produce the output from the input type and virtual costs associated with this conversion. One example line reads like this:

```
application/pdf          application/postscript    33    pdftops
```

This means that the *pdftops* filter will take *application/pdf* as input and produce *application/postscript* as output, the virtual cost of this operation is 33 CUPS-\$. The next filter is more expensive, costing 66 CUPS-\$:

```
application/vnd.hp-HPGL application/postscript    66    hpgltops
```

This is the *hpgltops*, which processes HP-GL plotter files to PostScript.

```
application/octet-stream
```

Here are two more examples:

```
application/x-shell      application/postscript  33    texttops
text/plain              application/postscript  33    texttops
```

The last two examples name the *texttops* filter to work on "text/plain" as well as on "application/x-shell". (Hint: this differentiation is needed for the syntax highlighting feature of "texttops").

19.5.3. Filter Requirements

There are many more combinations named in *mime.convs*. However, you are not limited to use the ones pre-defined there. You can plug in any filter you like into the CUPS framework. It must meet, or must be made to meet some minimal requirements. If you find (or write) a cool conversion filter of some kind, make sure it complies to what CUPS needs, and put in the right lines in *mime.types* and *mime.convs*, then it will work seamlessly inside CUPS!

TIP

The mentioned "CUPS requirements" for filters are simple. Take filenames or *stdin* as input and write to *stdout*. They should take these 5 or 6 arguments: *printer job user title copies options [filename]*

Printer The name of the printer queue (normally this is the name of the filter being run)

job The numeric job ID for the job being printed



Printer The string from the originating-user-name attribute

Printer The string from the job-name attribute

Printer The numeric value from the number-copies attribute

Printer The job options

Printer (Optionally) The print request file (if missing, filters expected data fed through *stdin*). In most cases it is very easy to write a simple wrapper script around existing filters to make them work with CUPS.

19.5.4. Prefilters

As was said, PostScript is the central file format to any Unix based printing system. From PostScript, CUPS generates raster data to feed non-PostScript printers.

But what is happening if you send one of the supported non-PS formats to print? Then CUPS runs "pre-filters" on these input formats to generate PostScript first. There are pre-filters to create PS from ASCII text, PDF, DVI or HP-GL. The outcome of these filters is always of MIME type *application/postscript* (meaning that any device-specific print options are not yet embedded into the PostScript by CUPS, and that the next filter to be called is *pstops*). Another pre-filter is running on all supported image formats, the *imagetops* filter. Its outcome is always of MIME type *application/vnd.cups-postscript* (not *application/postscript*), meaning it has the print options already embedded into the file.

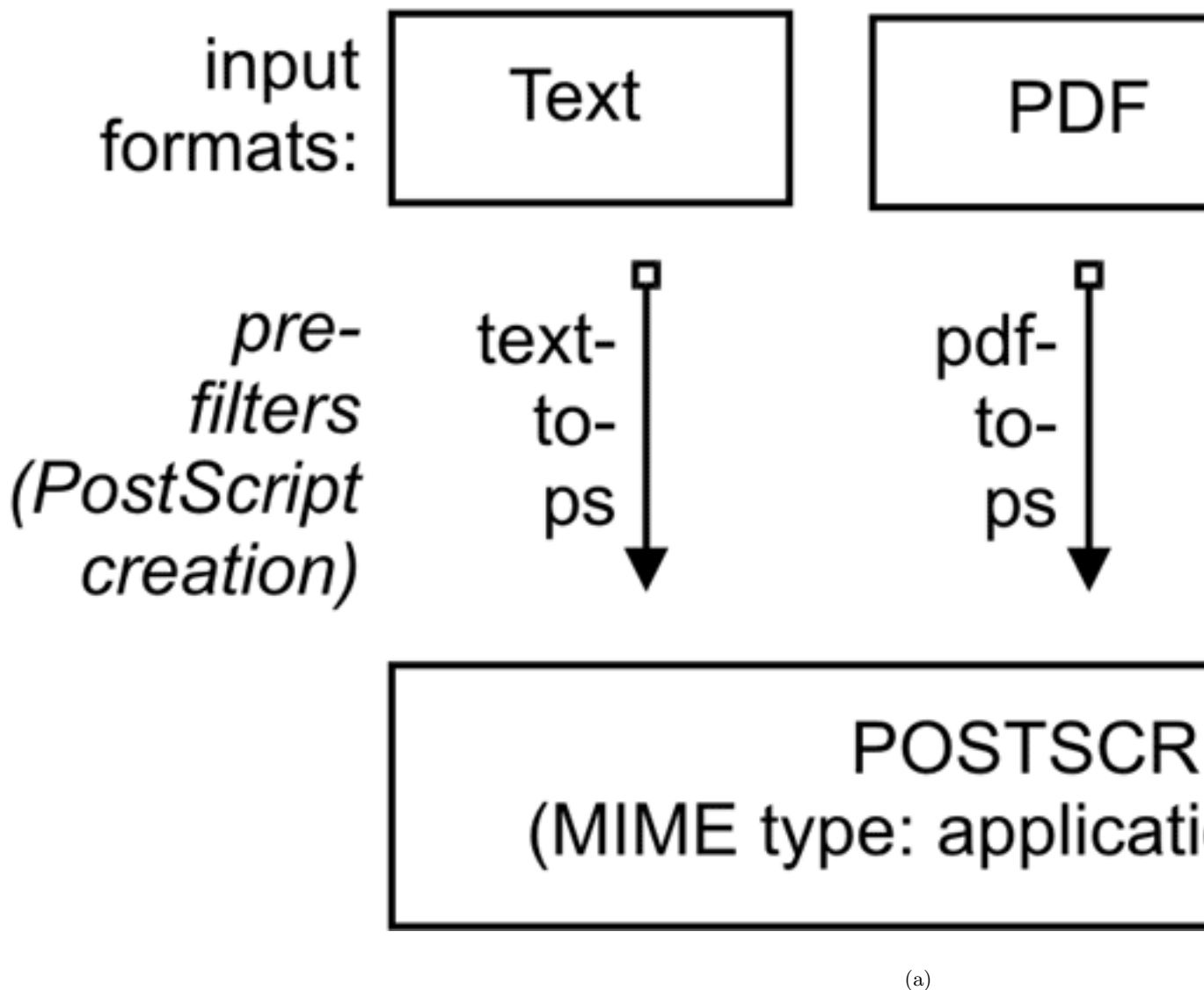

Figure 19.4: Prefiltering in CUPS to form Postscript

19.5.5. pstops

pstops is the filter to convert *application/postscript* to *application/vnd.cups-postscript*. It was said above that this filter inserts all device-specific print options (commands to the printer to ask for the duplexing of output, or stapling an punching it, etc.)

into the PostScript file.

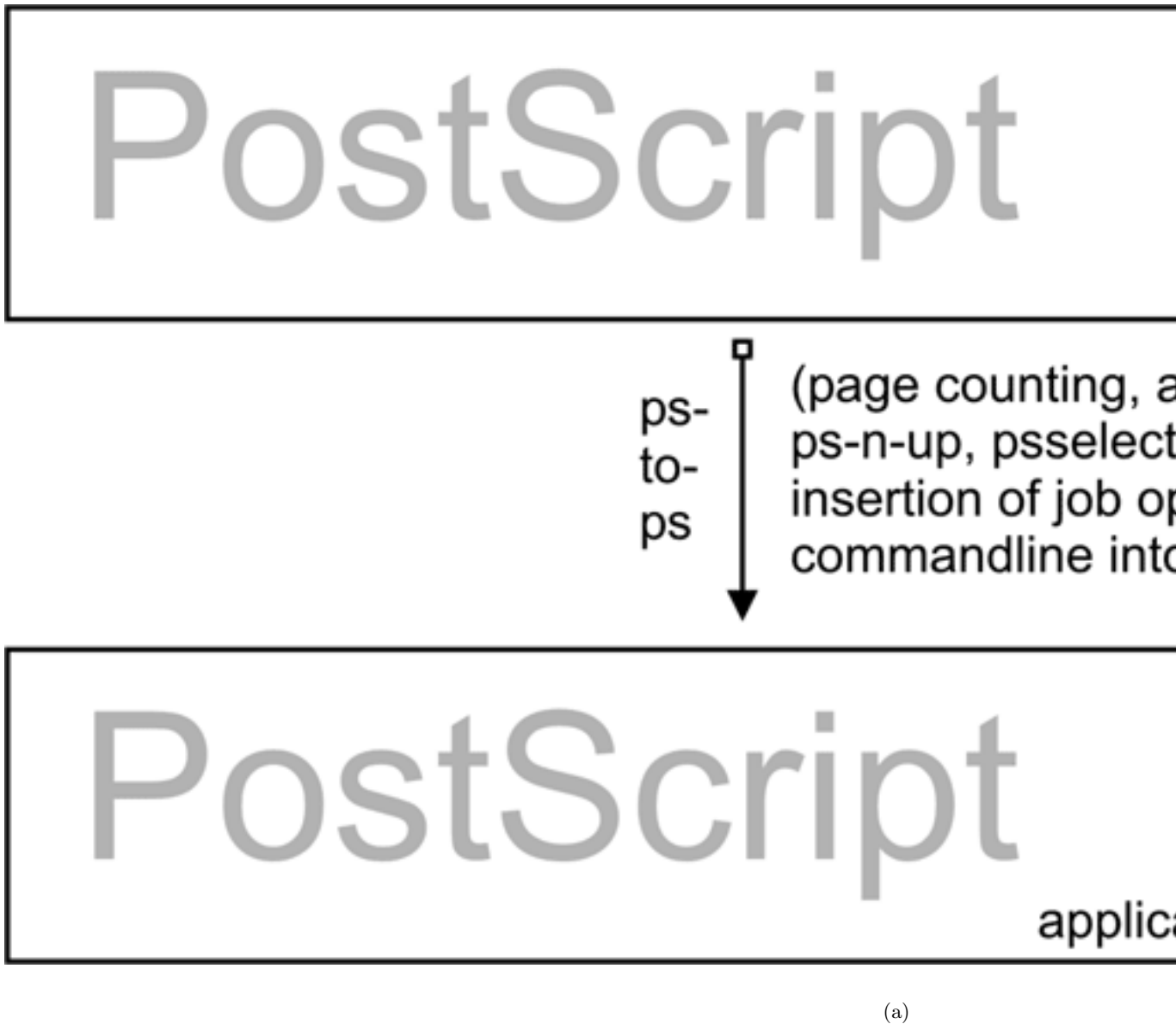

Figure 19.5: Adding Device-specific Print Options

This is not all: other tasks performed by it are:

- selecting the range of pages to be printed (if you choose to print only pages "3, 6, 8-11, 16, 19-21", or only the odd numbered ones)
- putting 2 or more logical pages on one sheet of paper (the so-called "number-up" function)
- counting the pages of the job to insert the accounting information into the `/var/log/cups/page_log`

19.5.6. `pstoraster`

`pstoraster` is at the core of the CUPS filtering system. It is responsible for the first stage of the rasterization process. Its input is of MIME type `application/vnd.cups-postscript`; its output is `application/vnd.cups-raster`. This output format is not yet

meant to be printable. Its aim is to serve as a general purpose input format for more specialized *raster drivers*, that are able to generate device-specific printer data.

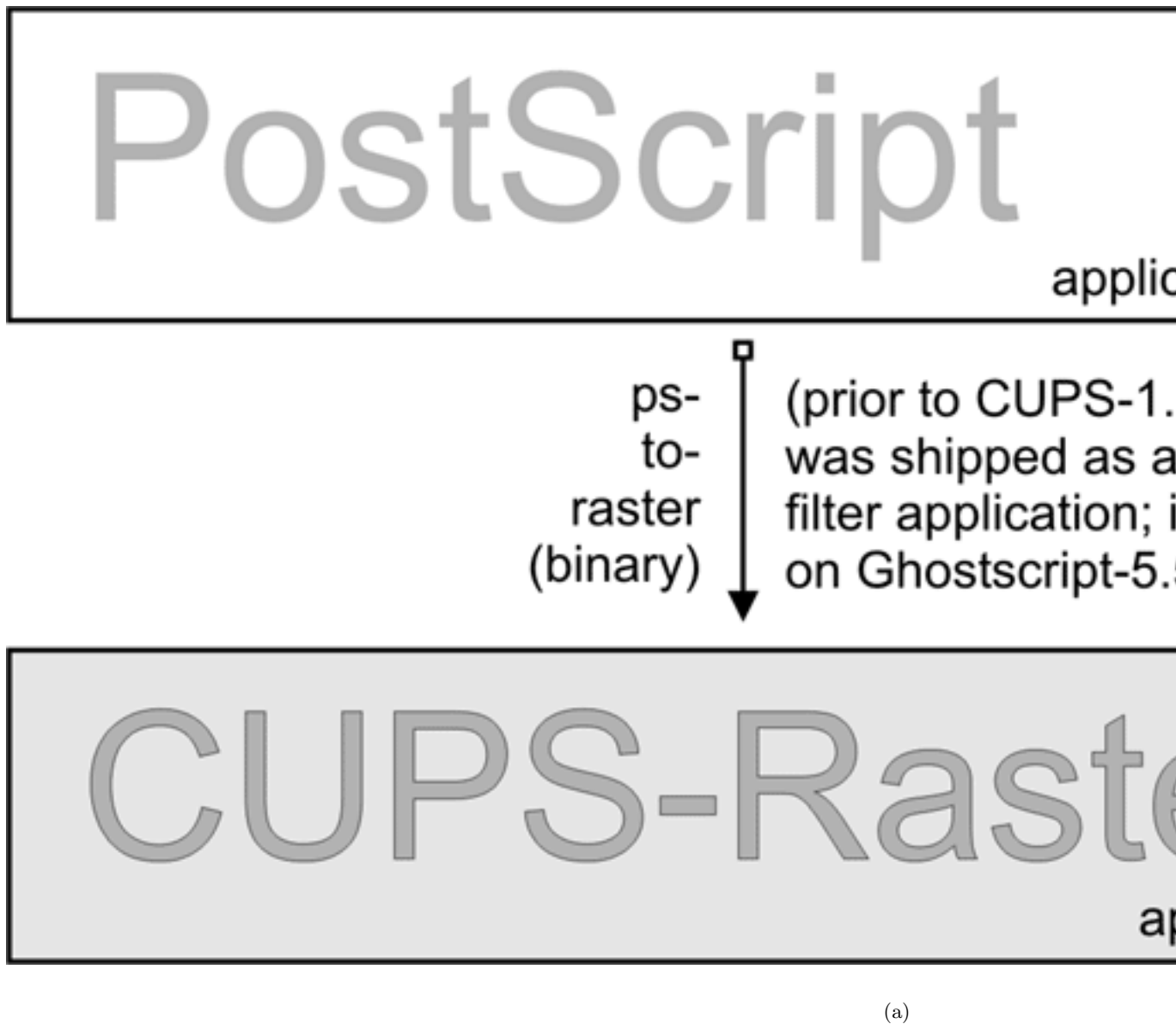

Figure 19.6: Postscript to intermediate Raster format

CUPS raster is a generic raster format with powerful features. It is able to include per-page information, color profiles and more to be used by the following downstream raster drivers. Its MIME type is registered with IANA and its specification is of course completely open. It is designed to make it very easy and inexpensive for manufacturers to develop Linux and Unix raster drivers for their printer models, should they choose to do so. CUPS always takes care for the first stage of rasterization so these vendors don't need to care about Ghostscript complications (in fact, there is currently more than one vendor financing the development of CUPS raster drivers).

CUPS versions before version 1.1.15 were shipping a binary (or source code) standalone filter, named "pstoraster". pstoraster was derived from GNU Ghostscript 5.50, and could be installed besides and in addition to any GNU or AFPL Ghostscript

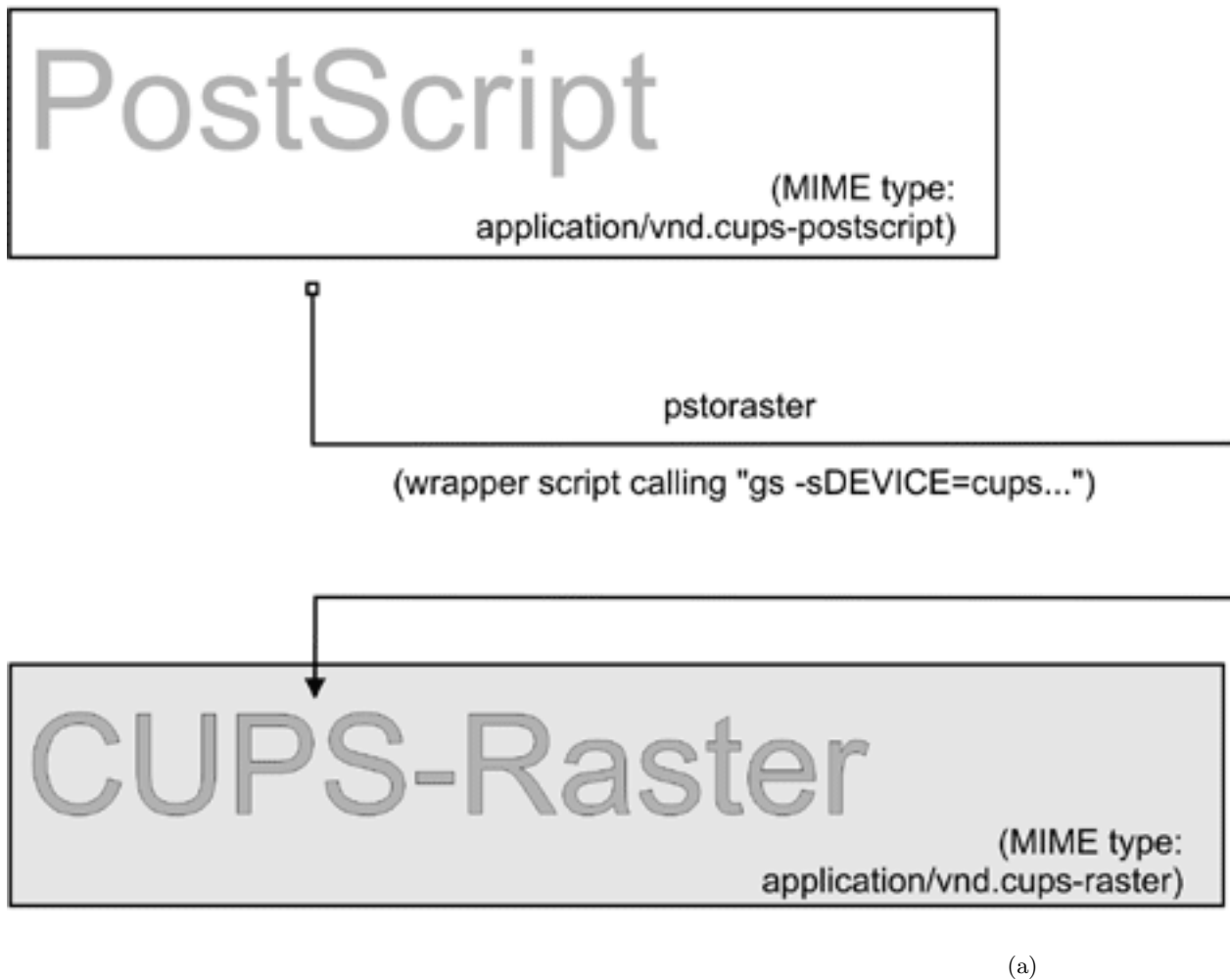

Figure 19.7: CUPS-raster production using Ghostscript

package without conflicting.

From version 1.1.15, this has changed. The functions for this has been integrated back into Ghostscript (now based on GNU Ghostscript version 7.05). The "pstoraster" filter is now a simple shell script calling `gs` with the `-sDEVICE=cups` parameter. If your Ghostscript doesn't show a success on asking for `gs -h --grep cups`, you might not be able to print. Update your Ghostscript then!

19.5.7. imagetops and imagetoraster

Above in the section about prefilters, we mentioned the prefilter that generates PostScript from image formats. The `imagetoraster` filter is used to convert directly from image to raster, without the intermediate PostScript stage. It is used more often than the above mentioned prefilters. Here is a summarizing flowchart of image file filtering:

19.5.8. rasterto [printerspecific]

CUPS ships with quite some different raster drivers processing CUPS raster. On my system I find in `/usr/lib/cups/filter/` these: `rastertoalps`, `rastertobj`, `raster-toepson`, `rastertoescp`, `rastertopcl`, `rastertoturboprint`, `rastertoapdk`, `rastertodymo`,

rastertoescp, rastertohp and rastertoprinter. Don't worry if you have less than this; some of these are installed by commercial add-ons to CUPS (like rastertoturbo-print), others (like rastertoprinter) by 3rd party driver development projects (such as Gimp-Print) wanting to cooperate as closely as possible with CUPS.

19.5.9. CUPS Backends

The last part of any CUPS filtering chain is a "backend". Backends are special programs that send the print-ready file to the final device. There is a separate backend program for any transfer "protocol" of sending printjobs over the network, or for every local interface. Every CUPS printqueue needs to have a CUPS "device-URI" associated with it. The device URI is the way to encode the backend used to send the job to its destination. Network device-URIs are using two slashes in their syntax, local device URIs only one, as you can see from the following list. Keep in mind that local interface names may vary much from my examples, if your OS is not Linux:

usb This backend sends printfiles to USB-connected printers. An example for the CUPS device-URI to use is: `usb:/dev/usb/lp0`

serial This backend sends printfiles to serially connected printers. An example for the CUPS device-URI to use is: `serial:/dev/ttyS0?baud=11500`

parallel This backend sends printfiles to printers connected to the parallel port. An example for the CUPS device-URI to use is: `parallel:/dev/lp0`

scsi This backend sends printfiles to printers attached to the SCSI interface. An example for the CUPS device-URI to use is: `scsi:/dev/sr1`

lpd This backend sends printfiles to LPR/LPD connected network printers. An example for the CUPS device-URI to use is: `lpd://remote_host_name/remote_queue_name`

AppSocket/HP JetDirect This backend sends printfiles to AppSocket (a.k.a. "HP JetDirect") connected network printers. An example for the CUPS device-URI to use is: `socket://10.11.12.13:9100`

ipp This backend sends printfiles to IPP connected network printers (or to other CUPS servers). Examples for CUPS device-URIs to use are: `ipp://192.193.194.195/ipp` (for many HP printers) or `ipp://remote_cups_server/printers/remote_printer_name`

http This backend sends printfiles to HTTP connected printers. (The `http://` CUPS backend is only a symlink to the `ipp://` backend.) Examples for the CUPS device-URIs to use are: `http://192.193.194.195:631/ipp` (for many HP printers) or `http://remote_cups_server:631/printers/remote_printer_name`

smb This backend sends printfiles to printers shared by a Windows host. An example for CUPS device-URIs to use are: `smb://workgroup/server/printers/sharename` Or `Smb://server/printers/sharename` or `smb://username:password@workgroup/server/printers/sharename` or `smb://username:password@server/printers/sharename`. The `smb://` backend is a symlink to the Samba utility `smbpool` (doesn't ship with CUPS). If the symlink is not present in your CUPS backend directory, have your root user create it: `ln -s 'which smbpool' /usr/lib/cups/backend/smb`.

It is easy to write your own backends as Shell or Perl scripts, if you need any modification or extension to the CUPS print system. One reason could be that you want to create "special" printers which send the printjobs as email (through a "mailto:/" backend), convert them to PDF (through a "pdfgen:/" backend) or dump them to "/dev/null" (In fact I have the system-wide default printer set up to be connected to a "devnull:/" backend: there are just too many people sending jobs without specifying a printer, or scripts and programs which don't name a printer. The system-wide default deletes the job and sends a polite mail back to the \$USER asking him to always specify a correct printername).

Not all of the mentioned backends may be present on your system or usable (depending on your hardware configuration). One test for all available CUPS backends is provided by the *lpinfo* utility. Used with the *-v* parameter, it lists all available backends:

```
lpinfo -v
```

19.5.10. cupsomatic/Foomatic – how do they fit into the Picture?

”cupsomatic” filters may be the most widely used on CUPS installations. You must be clear about the fact that these were not developed by the CUPS people. They are a ”Third Party” add-on to CUPS. They utilize the traditional Ghostscript devices to render jobs for CUPS. When troubleshooting, you should know about the difference. Here the whole rendering process is done in one stage, inside Ghostscript, using an appropriate ”device” for the target printer. cupsomatic uses PPDs which are generated from the ”Foomatic” Printer & Driver Database at Linuxprinting.org.

You can recognize these PPDs from the line calling the *cupsomatic* filter:

```
*cupsFilter: "application/vnd.cups-postscript 0 cupsomatic"
```

This line you may find amongst the first 40 or so lines of the PPD file. If you have such a PPD installed, the printer shows up in the CUPS web interface with a *foomatic* namepart for the driver description. cupsomatic is a Perlscript that runs Ghostscript, with all the complicated commandline options auto-constructed from the selected PPD and commandline options give to the printjob.

However, cupsomatic is now deprecated. Its PPDs (especially the first generation of them, still in heavy use out there) are not meeting the Adobe specifications. You might also suffer difficulties when you try to download them with ”Point’n’Print” to Windows clients. A better, and more powerful successor is now in a very stable Beta-version available: it is called *foomatic-rip*. To use *foomatic-rip* as a filter with CUPS, you need the new-type PPDs. These have a similar, but different line:

```
*cupsFilter: "application/vnd.cups-postscript 0 foomatic-rip"
```

The PPD generating engine at Linuxprinting.org has been revamped. The new PPDs comply to the Adobe spec. On top, they also provide a new way to specify different quality levels (hi-res photo, normal color, grayscale, draft...) with a single click (whereas before you could have required 5 or more different selections (media type, resolution, inktype, dithering algorithm...)). There is support for custom-size media built in. There is support to switch print-options from page to page, in the middle of a job. And the best thing is: the new *foomatic-rip* now works seamlessly with all legacy spoolers too (like LPRng, BSD-LPD, PDQ, PPR etc.), providing for them access to use PPDs for their printing!

19.5.11. The Complete Picture

If you want to see an overview over all the filters and how they relate to each other, the complete picture of the puzzle is at the end of this document.

19.5.12. mime.convs

CUPS auto-constructs all possible filtering chain paths for any given MIME type, and every printer installed. But how does it decide in favor or against a specific alternative? (There may often be cases, where there is a choice of two or more possible filtering chains for the same target printer). Simple: you may have noticed the figures in the 3rd column of the mime.convs file. They represent virtual costs assigned to this filter. Every possible filtering chain will sum up to a total "filter cost". CUPS decides for the most "inexpensive" route.

TIP



The setting of `FilterLimit 1000` in `cupsd.conf` will not allow more filters to run concurrently than will consume a total of 1000 virtual filter cost. This is a very efficient way to limit the load of any CUPS server by setting an appropriate "FilterLimit" value. A `FilterLimit` of 200 allows roughly 1 job at a time, while a `FilterLimit` of 1000 allows approximately 5 jobs maximum at a time.

19.5.13. "Raw" printing

You can tell CUPS to print (nearly) any file "raw". "Raw" means it will not be filtered. CUPS will send the file to the printer "as is" without bothering if the printer is able to digest it. Users need to take care themselves that they send sensible data formats only. Raw printing can happen on any queue if the "-o raw" option is specified on the command line. You can also set up raw-only queues by simply not associating any PPD with it. This command:

```
lpadmin -P rawprinter -v socket://11.12.13.14:9100 -E
```

sets up a queue named "rawprinter", connected via the "socket" protocol (a.k.a. "HP JetDirect") to the device at IP address 11.12.13.14, using port 9100. (If you had added a PPD with `-P /path/to/PPD` to this command line, you would have installed a "normal" printqueue.

CUPS will automatically treat each job sent to a queue as a "raw" one, if it can't find a PPD associated with the queue. However, CUPS will only send known MIME types (as defined in its own mime.types file) and refuse others.

19.5.14. "application/octet-stream" printing

Any MIME type with no rule in the `/etc/cups/mime.types` file is regarded as unknown or `application/octet-stream` and will not be sent. Because CUPS refuses to print unknown MIME types per default, you will probably have experienced the fact

that printjobs originating from Windows clients were not printed. You may have found an error message in your CUPS logs like:

```
Unable to convert file 0 to printable format for job
```

To enable the printing of "application/octet-stream" files, edit these two files:

- /etc/cups/mime.convs
- /etc/cups/mime.types

Both contain entries (at the end of the respective files) which must be uncommented to allow RAW mode operation for application/octet-stream. In /etc/cups/mime.types make sure this line is present:

```
application/octet-stream
```

This line (with no specific auto-typing rule set) makes all files not otherwise auto-typed a member of application/octet-stream. In /etc/cups/mime.convs, have this line:

```
application/octet-stream application/vnd.cups-raw 0 -
```

This line tells CUPS to use the *Null Filter* (denoted as "-", doing... nothing at all) on *application/octet-stream*, and tag the result as *application/vnd.cups-raw*. This last one is always a green light to the CUPS scheduler to now hand the file over to the "backend" connecting to the printer and sending it over.

NOTE



Editing the `mime.convs` and the `mime.types` file does not *enforce* "raw" printing, it only *allows* it.

Background CUPS being a more security-aware printing system than traditional ones does not by default allow one to send deliberate (possibly binary) data to printing devices. (This could be easily abused to launch a Denial of Service attack on your printer(s), causing at least the loss of a lot of paper and ink...) "Unknown" data are regarded by CUPS as *MIME type application/octet-stream*. While you *can* send data "raw", the MIME type for these must be one that is known to CUPS and an allowed one. The file /etc/cups/mime.types defines the "rules" how CUPS recognizes MIME types. The file /etc/cups/mime.convs decides which file conversion filter(s) may be applied to which MIME types.

19.5.15. PostScript Printer Descriptions (PPDs) for non-PS Printers

Originally PPDs were meant to be used for PostScript printers only. Here, they help to send device-specific commands and settings to the RIP which processes the jobfile. CUPS has extended this scope for PPDs to cover non-PostScript printers too. This was not very difficult, because it is a standardized file format. In a way it was logical too: CUPS handles PostScript and uses a PostScript RIP (=Ghostscript) to process the jobfiles. The only difference is: a PostScript printer has the RIP built-in, for other types of printers the Ghostscript RIP runs on the host computer.

PPDs for a non-PS printer have a few lines that are unique to CUPS. The most important one looks similar to this:

```
*cupsFilter: application/vnd.cups-raster 66 rastertoprinter
```

It is the last piece in the CUPS filtering puzzle. This line tells the CUPS daemon to use as a last filter "rastertoprinter". This filter should be served as input an "application/vnd.cups-raster" MIME type file. Therefore CUPS should auto-construct a filtering chain, which delivers as its last output the specified MIME type. This is then taken as input to the specified "rastertoprinter" filter. After this the last filter has done its work ("rastertoprinter" is a Gimp-Print filter), the file should go to the backend, which sends it to the output device.

CUPS by default ships only a few generic PPDs, but they are good for several hundred printer models. You may not be able to control different paper trays, or you may get larger margins than your specific model supports):

deskjet.ppd older HP inkjet printers and compatible

deskjet2.ppd newer HP inkjet printers and compatible

dymo.ppd label printers

epson9.ppd Epson 24pin impact printers and compatible

epson24.ppd Epson 24pin impact printers and compatible

okidata9.ppd Okidata 9pin impact printers and compatible

okidat24.ppd Okidata 24pin impact printers and compatible

stcolor.ppd older Epson Stylus Color printers

stcolor2.ppd newer Epson Stylus Color printers

stphoto.ppd older Epson Stylus Photo printers

stphoto2.ppd newer Epson Stylus Photo printers

laserjet.ppd all PCL printers Further below is a discussion of several other driver/PPD-packages suitable for use with CUPS.

19.5.16. Difference between cupsomatic/foomatic-rip and native CUPS printing

Native CUPS rasterization works in two steps.

- First is the "pstoraster" step. It uses the special "cups" device from ESP Ghostscript 7.05.x as its tool
- Second comes the "rasterdriver" step. It uses various device-specific filters; there are several vendors who provide good quality filters for this step, some are Free Software, some are Shareware/Non-Free, some are proprietary.

Often this produces better quality (and has several more advantages) than other methods.

One other method is the *cupsomatic/foomatic-rip* way. Note that *cupsomatic* is *not* made by the CUPS developers. It is an independent contribution to printing development, made by people from [Linuxprinting.org](http://www.cups.org/cups-help.html) (see also <http://www.cups.org/cups-help.html>). *cupsomatic* is no longer developed and maintained and is no longer supported. It has now been replaced by *foomatic-rip*. *foomatic-rip* is a complete re-write of the old *cupsomatic* idea, but very much improved and generalized to other (non-CUPS) spoolers. An upgrade to *foomatic-rip* is strongly advised, especially if you are upgrading to a recent version of CUPS too.

Both the *cupsomatic* (old) and the *foomatic-rip* (new) methods from [Linuxprinting.org](http://www.cups.org) use the traditional Ghostscript print file processing, doing everything in a single step. It therefore relies on all the other devices built-in into Ghostscript. The quality is as good (or bad) as Ghostscript rendering is in other spoolers. The advantage is that this method supports many printer models not supported (yet) by the more modern CUPS method.

Of course, you can use both methods side by side on one system (and even for one printer, if you set up different queues), and find out which works best for you.

cupsomatic "kidnaps" the printfile after the *application/vnd.cups-postscript* stage and deviates it through the CUPS-external, systemwide Ghostscript installation: Therefore the printfile bypasses the "pstoraster" filter (and thus also bypasses the CUPS-raster-drivers "rastertosomething"). After Ghostscript finished its rasterization, *cupsomatic* hands the rendered file directly to the CUPS backend. The flowchart above illustrates the difference between native CUPS rendering and the *Foomatic/cupsomatic* method.

19.5.17. Examples for filtering Chains

Here are a few examples of commonly occurring filtering chains to illustrate the workings of CUPS.

Assume you want to print a PDF file to a HP JetDirect-connected PostScript printer, but you want to print the pages 3-5, 7, 11-13 only, and you want to print them "2-up" and "duplex":

- your print options (page selection as required, 2-up, duplex) are passed to CUPS on the commandline;
- the (complete) PDF file is sent to CUPS and autotyped as *application/pdf*;
- the file therefore first must pass the *pdftops* pre-filter, which produces PostScript MIME type *application/postscript* (a preview here would still show all pages of the original PDF);
- the file then passes the *pstops* filter which applies the commandline options: it selects the pages 2-5, 7 and 11-13, creates and imposed layout "2 pages on 1 sheet" and inserts the correct "duplex" command (as is defined in the printer's PPD) into the new PostScript file; the file now is of PostScript MIME type *application/vnd.cups-postscript*;
- the file goes to the *socket* backend, which transfers the job to the printers.

The resulting filter chain therefore is:

```
pdftops --> pstops --> socket
```

Assume your want to print the same filter to an USB-connected Epson Stylus Photo printer, installed with the CUPS *stphoto2.ppd*. The first few filtering stages are nearly the same:

- your print options (page selection as required, 2-up, duplex) are passed to CUPS on the commandline;

- the (complete) PDF file is sent to CUPS and autotyped as *application/pdf*;
- the file therefore first must pass the *pdftops* pre-filter, which produces PostScript MIME type *application/postscript* (a preview here would still show all pages of the original PDF);
- the file then passes the "pstops" filter which applies the commandline options: it selects the pages 2-5, 7 and 11-13, creates and imposed layout "2 pages on 1 sheet" and inserts the correct "duplex" command... (OOoops – this printer and his PPD don't support duplex printing at all – this option will be ignored then) into the new PostScript file; the file now is of PostScript MIME type *application/vnd.cups-postscript*;
- the file then passes the *pstoraster* stage and becomes MIME type *application/cups-raster*;
- finally, the *rastertoepson* filter does its work (as is indicated in the printer's PPD), creating the printer-specific raster data and embedding any user-selected print-options into the print data stream;
- the file goes to the *usb* backend, which transfers the job to the printers.

The resulting filter chain therefore is:

```
pdftops --> pstops --> pstoraster --> rastertoepson --> usb
```

19.5.18. Sources of CUPS drivers / PPDs

On the internet you can find now many thousand CUPS-PPD files (with their companion filters), in many national languages, supporting more than 1000 non-PostScript models.

- **ESP PrintPro** (<http://www.easysw.com/printpro/>) (commercial, non-Free) is packaged with more than 3000 PPDs, ready for successful use "out of the box" on Linux, Mac OS X, IBM-AIX, HP-UX, Sun-Solaris, SGI-IRIX, Compaq Tru64, Digital Unix and some more commercial Unices (it is written by the CUPS developers themselves and its sales help finance the further development of CUPS, as they feed their creators).
- the **Gimp-Print-Project** (<http://gimp-print.sourceforge.net/>) (GPL, Free Software) provides around 140 PPDs (supporting nearly 400 printers, many driven to photo quality output), to be used alongside the Gimp-Print CUPS filters;
- **TurboPrint** (<http://www.turboprint.com/>) (Shareware, non-Free) supports roughly the same amount of printers in excellent quality;
- **OMNI** (<http://www-124.ibm.com/developerworks/oss/linux/projects/omni/>) (LGPL, Free) is a package made by IBM, now containing support for more than 400 printers, stemming from the inheritance of IBM OS/2 KnowHow ported over to Linux (CUPS support is in a Beta-stage at present);
- **HPIJS** (<http://hpinkjet.sourceforge.net/>) (BSD-style licenses, Free) supports around 150 of HP's own printers and is also providing excellent print quality now (currently available only via the Foomatic path);
- **Foomatic/cupsomatic** (<http://www.linuxprinting.org/>) (LGPL, Free) from Linuxprinting.org are providing PPDs for practically every Ghostscript filter known to the world (including Omni, Gimp-Print and HPIJS).

NOTE



The cupsomatic/Foomatic trick from [Linuxprinting.org](http://linuxprinting.org) works differently from the other drivers. This is explained elsewhere in this document.

19.5.19. Printing with Interface Scripts

CUPS also supports the usage of "interface scripts" as known from System V AT&T printing systems. These are often used for PCL printers, from applications that generate PCL print jobs. Interface scripts are specific to printer models. They have a similar role as PPDs for PostScript printers. Interface scripts may inject the Escape sequences as required into the print data stream, if the user has chosen to select a certain paper tray, or print landscape, or use A3 paper, etc. Interfaces scripts are practically unknown in the Linux realm. On HP-UX platforms they are more often used. You can use any working interface script on CUPS too. Just install the printer with the `-i` option:

```
lpadmin -p pclprinter -v socket://11.12.13.14:9100 -i /path/to/interface-script
```

Interface scripts might be the "unknown animal" to many. However, with CUPS they provide the most easy way to plug in your own custom-written filtering script or program into one specific print queue (some information about the traditional usage of interface scripts is to be found at <http://playground.sun.com/printing/documentation/interface.html>).

19.6. Network printing (purely Windows)

Network printing covers a lot of ground. To understand what exactly goes on with Samba when it is printing on behalf of its Windows clients, let's first look at a "purely Windows" setup: Windows clients with a Windows NT print server.

19.6.1. From Windows Clients to an NT Print Server

Windows clients printing to an NT-based print server have two options. They may

- execute the driver locally and render the GDI output (EMF) into the printer specific format on their own, or
- send the GDI output (EMF) to the server, where the driver is executed to render the printer specific output.

Both print paths are shown in the flowcharts below.

19.6.2. Driver Execution on the Client

In the first case the print server must spool the file as "raw", meaning it shouldn't touch the jobfile and try to convert it in any way. This is what traditional Unix-based print server can do too; and at a better performance and more reliably than NT print server. This is what most Samba administrators probably are familiar with. One advantage of this setup is that this "spooling-only" print server may be used even if

no driver(s) for Unix are available it is sufficient to have the Windows client drivers available and installed on the clients.

19.6.3. Driver Execution on the Server

The other path executes the printer driver on the server. The clients transfers print files in EMF format to the server. The server uses the PostScript, PCL, ESC/P or other driver to convert the EMF file into the printer-specific language. It is not possible for Unix to do the same. Currently there is no program or method to convert a Windows client's GDI output on a Unix server into something a printer could understand.

However, there is something similar possible with CUPS. Read on...

19.7. Network Printing (Windows clients – UNIX/Samba Print Servers)

Since UNIX print servers *cannot* execute the Win32 program code on their platform, the picture is somewhat different. However, this doesn't limit your options all that much. In the contrary, you may have a way here to implement printing features which are not possible otherwise.

19.7.1. From Windows Clients to a CUPS/Samba Print Server

Here is a simple recipe showing how you can take advantage of CUPS powerful features for the benefit of your Windows network printing clients:

- Let the Windows clients send PostScript to the CUPS server.
- Let the CUPS server render the PostScript into device specific raster format.

This requires the clients to use a PostScript driver (even if the printer is a non-PostScript model. It also requires that you have a "driver" on the CUPS server.

Firstly, to enable CUPS based printing through Samba the following options should be set in your `smb.conf` file [globals] section:

- `printing = CUPS`
- `printcap = CUPS`

When these parameters are specified, all manually set print directives (like `print command =...`, or `lppause command =...`) in `smb.conf` (as well as in samba itself) will be ignored. Instead, Samba will directly interface with CUPS through it's application program interface (API) - as long as Samba has been compiled with CUPS library (`libcups`) support. If Samba has NOT been compiled with CUPS support, and if no other print commands are set up, then printing will use the *System V* AT&T command set, with the `-oraw` option automatically passing through (if you want your own defined print commands to work with a Samba that has CUPS support compiled in, simply use `printing = sysv`).

19.7.2. Samba receiving Jobfiles and passing them to CUPS

Sambamust use its own spool directory (it is set by a line similar to `path = /var/spool/samba,` in the [printers] or [printername] section of `smb.conf`). Samba receives the job in its own spool space and passes it into the spool directory of CUPS (the CUPS spooling directory is set by the `RequestRoot` directive, in a line that defaults to `RequestRoot /var/spool/cups`). CUPS checks the access rights of its spool dir and resets it to healthy values with every re-start. We have seen quite some people who had used

a common spooling space for Samba and CUPS, and were struggling for weeks with this "problem".

A Windows user authenticates only to Samba (by whatever means is configured). If Samba runs on the same host as CUPS, you only need to allow "localhost" to print. If they run on different machines, you need to make sure the Samba host gets access to printing on CUPS.

19.8. Network PostScript RIP: CUPS Filters on Server – clients use PostScript Driver with CUPS-PPDs

PPDs can control all print device options. They are usually provided by the manufacturer; if you own a PostScript printer, that is. PPD files (PostScript Printer Descriptions) are always a component of PostScript printer drivers on MS Windows or Apple Mac OS systems. They are ASCII files containing user-selectable print options, mapped to appropriate PostScript, PCL or PJI commands for the target printer. Printer driver GUI dialogs translate these options "on-the-fly" into buttons and drop-down lists for the user to select.

CUPS can load, without any conversions, the PPD file from any Windows (NT is recommended) PostScript driver and handle the options. There is a web browser interface to the print options (select <http://localhost:631/printers/> and click on one *Configure Printer* button to see it), or a commandline interface (see **man lpoptions** or see if you have `lphelp` on your system). There are also some different GUI frontends on Linux/UNIX, which can present PPD options to users. PPD options are normally meant to be evaluated by the PostScript RIP on the real PostScript printer.

19.8.1. PPDs for non-PS Printers on UNIX

CUPS doesn't limit itself to "real" PostScript printers in its usage of PPDs. The CUPS developers have extended the scope of the PPD concept, to also describe available device and driver options for non-PostScript printers through CUPS-PPDs.

This is logical, as CUPS includes a fully featured PostScript interpreter (RIP). This RIP is based on Ghostscript. It can process all received PostScript (and additionally many other file formats) from clients. All CUPS-PPDs geared to non-PostScript printers contain an additional line, starting with the keyword `*cupsFilter`. This line tells the CUPS print system which printer-specific filter to use for the interpretation of the supplied PostScript. Thus CUPS lets all its printers appear as PostScript devices to its clients, because it can act as a PostScript RIP for those printers, processing the received PostScript code into a proper raster print format.

19.8.2. PPDs for non-PS Printers on Windows

CUPS-PPDs can also be used on Windows-Clients, on top of a "core" PostScript driver (now recommended is the "CUPS PostScript Driver for WindowsNT/2K/XP"; you can also use the Adobe one, with limitations). This feature enables CUPS to do a few tricks no other spooler can do:

- act as a networked PostScript RIP (Raster Image Processor), handling printfiles from all client platforms in a uniform way;
- act as a central accounting and billing server, since all files are passed through the `pstops` filter and are therefore logged in the CUPS `page_log` file. *NOTE:* this can not happen with "raw" print jobs, which always remain unfiltered per definition;

- enable clients to consolidate on a single PostScript driver, even for many different target printers.

Using CUPS PPDs on Windows clients enables these to control all print job settings just as a UNIX client can do too.

19.9. Windows Terminal Servers (WTS) as CUPS Clients

This setup may be of special interest to people experiencing major problems in WTS environments. WTS need often a multitude of non-PostScript drivers installed to run their clients' variety of different printer models. This often imposes the price of much increased instability.

19.9.1. Printer Drivers running in "Kernel Mode" cause many Problems

The reason is that in Win NT printer drivers run in "Kernel Mode", this introduces a high risk for the stability of the system if the driver is not really stable and well-tested. And there are a lot of bad drivers out there! Especially notorious is the example of the PCL printer driver that had an additional sound module running, to notify users via soundcard of their finished jobs. Do I need to say that this one was also reliably causing "Blue Screens of Death" on a regular basis?

PostScript drivers generally are very well tested. They are not known to cause any problems, even though they run in Kernel Mode too. This might be because there have so far only been 2 different PostScript drivers the ones from Adobe and the one from Microsoft. Both are very well tested and are as stable as you ever can imagine on Windows. The CUPS driver is derived from the Microsoft one.

19.9.2. Workarounds impose Heavy Limitations

In many cases, in an attempt to work around this problem, site administrators have resorted to restrict the allowed drivers installed on their WTS to one generic PCL- and one PostScript driver. This however restricts the clients in the amount of printer options available for them; often they can't get out more than simplex prints from one standard paper tray, while their devices could do much better, if driven by a different driver!)

19.9.3. CUPS: a "Magical Stone"?

Using a PostScript driver, enabled with a CUPS-PPD, seems to be a very elegant way to overcome all these shortcomings. There are, depending on the version of Windows OS you use, up to 3 different PostScript drivers available: Adobe, Microsoft and CUPS PostScript drivers. None of them is known to cause major stability problems on WTS (even if used with many different PPDs). The clients will be able to (again) chose paper trays, duplex printing and other settings. However, there is a certain price for this too: a CUPS server acting as a PostScript RIP for its clients requires more CPU and RAM than when just acting as a "raw spooling" device. Plus, this setup is not yet widely tested, although the first feedbacks look very promising.

19.9.4. PostScript Drivers with no major problems – even in Kernel Mode

More recent printer drivers on W2K and XP don't run in Kernel mode (unlike Win NT) any more. However, both operating systems can still use the NT drivers, running in Kernel mode (you can roughly tell which is which as the drivers in subdirectory

"2" of "W32X86" are "old" ones). As was said before, the Adobe as well as the Microsoft PostScript drivers are not known to cause any stability problems. The CUPS driver is derived from the Microsoft one. There is a simple reason for this: The MS DDK (Device Development Kit) for Win NT (which used to be available at no cost to licensees of Visual Studio) includes the source code of the Microsoft driver, and licensees of Visual Studio are allowed to use and modify it for their own driver development efforts. This is what the CUPS people have done. The license doesn't allow them to publish the whole of the source code. However, they have released the "diff" under the GPL, and if you are owner of an "MS DDK for Win NT", you can check the driver yourself.

19.10. Setting up CUPS for driver Download

As we have said before: all previously known methods to prepare client printer drivers on the Samba server for download and "Point'n'Print" convenience of Windows workstations are working with CUPS too. These methods were described in the previous chapter. In reality, this is a pure Samba business, and only relates to the Samba/Win client relationship.

19.10.1. cupsaddsmb: the unknown Utility

The cupsaddsmb utility (shipped with all current CUPS versions) is an alternative method to transfer printer drivers into the Samba [print\$] share. Remember, this share is where clients expect drivers deposited and setup for download and installation. It makes the sharing of any (or all) installed CUPS printers very easy. cupsaddsmb can use the Adobe PostScript driver as well as the newly developed *CUPS PostScript Driver for WinNT/2K/XP*. Note, that cupsaddsmb does *not* work with arbitrary vendor printer drivers, but only with the *exact* driver files that are named in its man page.

The CUPS printer driver is available from the CUPS download site. Its package name is `cups-samba-[version].tar.gz`. It is preferred over the Adobe drivers since it has a number of advantages:

- it supports a much more accurate page accounting;
- it supports banner pages, and page labels on all printers;
- it supports the setting of a number of job IPP attributes (such as job-priority, page-label and job-billing)

However, currently only Windows NT, 2000, and XP are supported by the CUPS drivers. You will need to get the respective part of Adobe driver too if you need to support Windows 95, 98, and ME clients.

19.10.2. Prepare your smb.conf for cupsaddsmb

Prior to running cupsaddsmb, you need the following settings in `smb.conf`:

```
[global]
    load printers = yes
    printing = cups
    printcap name = cups

[printers]
    comment = All Printers
```

```
path = /var/spool/samba
browseable = no
public = yes
guest ok = yes          # setting depends on your requirements
writable = no
printable = yes
printer admin = root

[print$]
comment = Printer Drivers
path = /etc/samba/drivers
browseable = yes
guest ok = no
read only = yes
write list = root
```

19.10.3. CUPS Package of "PostScript Driver for WinNT/2k/XP"

CUPS users may get the exactly same packages from <http://www.cups.org/software.html>. It is a separate package from the CUPS base software files, tagged as *CUPS 1.1.x Windows NT/2k/XP Printer Driver for SAMBA (tar.gz, 192k)*. The filename to download is `cups-samba-1.1.x.tar.gz`. Upon `untar-/unzip-ing`, it will reveal these files:

```
# tar xvzf cups-samba-1.1.19.tar.gz

cups-samba.install
cups-samba.license
cups-samba.readme
cups-samba.remove
cups-samba.ss
```

These have been packaged with the ESP meta packager software "EPM". The `*.install` and `*.remove` files are simple shell scripts, which untars the `*.ss` (the `*.ss` is nothing else but a tar-archive, which can be untar-ed by "tar" too). Then it puts the content into `/usr/share/cups/drivers/`. This content includes 3 files:

```
# tar tv cups-samba.ss

cupsdrv.dll
cupsui.dll
cups.hlp
```

The `cups-samba.install` shell scripts is easy to handle:

```
# ./cups-samba.install

[....]
Installing software...
Updating file permissions...
Running post-install commands...
Installation is complete.
```

The script should automatically put the driver files into the `/usr/share/cups/drivers/` directory.

WARNING

Due to a bug, one recent CUPS release puts the `cups.hlp` driver file into `/usr/share/drivers/` instead of `/usr/share/cups/drivers/`. To work around this, copy/move the file (after running the `./cups-samba.install` script) manually to the right place.

```
cp /usr/share/drivers/cups.hlp /usr/share/cups/drivers/
```

This new CUPS PostScript driver is currently binary-only, but free of charge. No complete source code is provided (yet). The reason is this: it has been developed with the help of the *Microsoft Driver Developer Kit* (DDK) and compiled with Microsoft Visual Studio 6. Driver developers are not allowed to distribute the whole of the source code as Free Software. However, CUPS developers released the "diff" in source code under the GPL, so anybody with a license of Visual Studio and a DDK will be able to compile for him/herself.

19.10.4. Recognize the different Driver Files

The CUPS drivers don't support the "older" Windows 95/98/ME, but only the Windows NT/2000/XP client:

```
[Windows NT, 2000, and XP are supported by:]
  cups.hlp
  cupsdrv.dll
  cupsui.dll
```

Adobe drivers are available for the older Windows 95/98/ME as well as the Windows NT/2000/XP clients. The set of files is different for the different platforms.

```
[Windows 95, 98, and Me are supported by:]
```

ADFONTS.MFM
ADOBEPS4.DRV
ADOBEPS4.HLP
DEFPRTR2.PPD
ICONLIB.DLL
PSMON.DLL

[Windows NT, 2000, and XP are supported by:]

ADOBEPS5.DLL
ADOBEPSU.DLL
ADOBEPSU.HLP

NOTE



If both, the Adobe driver files and the CUPS driver files for the support of WinNT/2k/XP are present in , the Adobe ones will be ignored and the CUPS ones will be used. If you prefer – for whatever reason – to use Adobe-only drivers, move away the 3 CUPS driver files. The Win95/98/ME clients use the Adobe drivers in any case.

19.10.5. Acquiring the Adobe Driver Files

Acquiring the Adobe driver files seems to be unexpectedly difficult for many users. They are not available on the Adobe website as single files and the self-extracting and/or self-installing Windows-exe is not easy to locate either. Probably you need to use the included native installer and run the installation process on one client once. This will install the drivers (and one Generic PostScript printer) locally on the client. When they are installed, share the Generic PostScript printer. After this, the client's [print\$] share holds the Adobe files, from where you can get them with smbclient from the CUPS host. A more detailed description about this is in the next (the CUPS printing) chapter.

19.10.6. ESP Print Pro Package of "PostScript Driver for WinNT/2k/XP"

Users of the ESP Print Pro software are able to install their "Samba Drivers" package for this purpose with no problem. Retrieve the driver files from the normal download area of the ESP Print Pro software at <http://www.easysw.com/software.html>. You need to locate the link labelled "SAMBA" amongst the *Download Printer Drivers for ESP Print Pro 4.x* area and download the package. Once installed, you can prepare any driver by simply highlighting the printer in the Printer Manager GUI and select *Export Driver...* from the menu. Of course you need to have prepared Samba beforehand too to handle the driver files; i.e. mainly setup the [print\$] share, etc. The ESP Print Pro package includes the CUPS driver files as well as a (licensed) set of Adobe drivers for the Windows 95/98/ME client family.

19.10.7. Caveats to be considered

Once you have run the install script (and possibly manually moved the `cups.hlp` file to `/usr/share/cups/drivers/`), the driver is ready to be put into Samba's `[print$]` share (which often maps to `/etc/samba/drivers/` and contains a subdir tree with `WIN40` and `W32X86` branches): You do this by running "cupsaddsmb" (see also `man cupsaddsmb` for CUPS since release 1.1.16).

TIP



You may need to put root into the `smbpasswd` file by running `smbpasswd`; this is especially important if you should run this whole procedure for the first time, and are not working in an environment where everything is configured for *Single Sign On* to a Windows Domain Controller.

Once the driver files are in the `[print$]` share and are initialized, they are ready to be downloaded and installed by the Win NT/2k/XP clients.

NOTE



1. Win 9x/ME clients won't work with the CUPS PostScript driver. For these you'd still need to use the ADOBE*. * drivers as previously.
2. It is not harmful if you still have the ADOBE*. * driver files from previous installations in the /usr/share/cups/drivers/ directory. The new *cup-saddsmb* (from 1.1.16) will automatically prefer "its own" drivers if it finds both.
3. Should your Win clients have had the old ADOBE*. * files for the Adobe PostScript driver installed, the download and installation of the new CUPS PostScript driver for Windows NT/2k/XP will fail at first. You need to wipe the old driver from the clients first. It is not enough to "delete" the printer, as the driver files will still be kept by the clients and re-used if you try to re-install the printer. To really get rid of the Adobe driver files on the clients, open the "Printers" folder (possibly via *Start -> Settings -> Control Panel -> Printers*), right-click onto the folder background and select *Server Properties*. When the new dialog opens, select the *Drivers* tab. On the list select the driver you want to delete and click on the *Delete* button. This will only work if there is not one single printer left which uses that particular driver. You need to "delete" all printers using this driver in the "Printers" folder first. You will need Administrator privileges to do this.
4. Once you have successfully downloaded the CUPS PostScript driver to a client, you can easily switch all printers to this one by proceeding as described elsewhere in the "Samba HOWTO Collection": either change a driver for an existing printer by running the "Printer Properties" dialog, or use **rpcclient** with the **setdriver** sub-command.

19.10.8. What are the Benefits of using the "CUPS PostScript Driver for Windows NT/2k/XP" as compared to the Adobe Driver?

You are interested in a comparison between the CUPS and the Adobe PostScript drivers? For our purposes these are the most important items which weigh in favor of the CUPS ones:

- no hassle with the Adobe EULA
- no hassle with the question 'Where do I get the ADOBE*. * driver files from?'
- the Adobe drivers (on request of the printer PPD associated with them) often put a PJI header in front of the main PostScript part of the print file. Thus the printfile starts with <1B >%-12345X or <escape>%-12345X instead of %!PS). This leads to the CUPS daemon auto-typing the incoming file as a print-ready file, not initiating a pass through the "pstops" filter (to speak more technically, it is not regarded as the generic MIME type *application/postscript*, but as

the more special MIME type *application/cups.vnd-postscript*), which therefore also leads to the page accounting in */var/log/cups/page.log* not receiving the exact number of pages; instead the dummy page number of "1" is logged in a standard setup)

- the Adobe driver has more options to "mis-configure" the PostScript generated by it (like setting it inadvertently to *Optimize for Speed*, instead of *Optimize for Portability*, which could lead to CUPS being unable to process it)
- the CUPS PostScript driver output sent by Windows clients to the CUPS server will be guaranteed to be auto-typed always as generic MIME type *application/postscript*, thusly passing through the CUPS "pstops" filter and logging the correct number of pages in the *page.log* for accounting and quota purposes
- the CUPS PostScript driver supports the sending of additional standard (IPP) print options by Win NT/2k/XP clients. Such additional print options are: naming the CUPS standard *banner pages* (or the custom ones, should they be installed at the time of driver download), using the CUPS *page-label* option, setting a *job-priority* and setting the *scheduled time of printing* (with the option to support additional useful IPP job attributes in the future).
- the CUPS PostScript driver supports the inclusion of the new **cupsJobTicket* comments at the beginning of the PostScript file (which could be used in the future for all sort of beneficial extensions on the CUPS side, but which will not disturb any other applications as they will regard it as a comment and simply ignore it).
- the CUPS PostScript driver will be the heart of the fully fledged CUPS IPP client for Windows NT/2K/XP to be released soon (probably alongside the first Beta release for CUPS 1.2).

19.10.9. Run "cupsaddsmb" (quiet Mode)

The `cupsaddsmb` command copies the needed files into your `[print$]` share. Additionally, the PPD associated with this printer is copied from `/etc/cups/ppd/` to `[print$]`. There the files wait for convenient Windows client installations via Point'n'Print. Before we can run the command successfully, we need to be sure that we can authenticate towards Samba. If you have a small network you are probably using user level security (`security = user`). Probably your root has already a Samba account. Otherwise, create it now, using `smbpasswd`:

```
# smbpasswd -a root
New SMB password: [type in password 'secret']
Retype new SMB password: [type in password 'secret']
```

Here is an example of a successfully run `cupsaddsmb` command.

```
# cupsaddsmb -U root infotec_IS2027
Password for root required to access localhost via SAMBA: [type in password 'secret']
```

To share *all* printers and drivers, use the `-a` parameter instead of a printer name. Since `cupsaddsmb` "exports" the printer drivers to Samba, it should be obvious that it only works for queues with a CUPS driver associated.

19.10.10. Run "cupsaddsmb" with verbose Output

Probably you want to see what's going on. Use the `-v` parameter to get a more verbose output. The output below was edited for better readability: all "`\`" at the end of a line indicate that I inserted an artificial line break plus some indentation here:

WARNING

You will see the root password for the Samba account printed on screen. If you use remote access, the password will go over the wire unencrypted!

```
# cupsaddsmb -U root -v infotec_2105
Password for root required to access localhost via SAMBA:
Running command: smbclient //localhost/print\$ -N -U'root%secret' -c 'mkdir W32X86
/var/spool/cups/tmp/3e98bf2d333b5 W32X86/infotec_2105.ppd;put
/usr/share/cups/drivers/cupsdrvrv.dll W32X86/cupsdrvrv.dll;put
/usr/share/cups/drivers/cupsui.dll W32X86/cupsui.dll;put
/usr/share/cups/drivers/cups.hlp W32X86/cups.hlp'
added interface ip=10.160.51.60 bcast=10.160.51.255 nmask=255.255.252.0
Domain=[CUPS-PRINT] OS=[Unix] Server=[Samba 2.2.7a]
NT_STATUS_OBJECT_NAME_COLLISION making remote directory \W32X86
putting file /var/spool/cups/tmp/3e98bf2d333b5 as \W32X86/infotec_2105.ppd (2328.8
(average 2328.8 kb/s)
putting file /usr/share/cups/drivers/cupsdrvrv.dll as \W32X86/cupsdrvrv.dll (9374.3
(average 5206.6 kb/s)
putting file /usr/share/cups/drivers/cupsui.dll as \W32X86/cupsui.dll (8107.2 kb/s)
(average 5984.1 kb/s)
putting file /usr/share/cups/drivers/cups.hlp as \W32X86/cups.hlp (3475.0 kb/s)
(average 5884.7 kb/s)

Running command: rpcclient localhost -N -U'root%secret' -c 'adddriver "Windows NT
"infotec_2105:cupsdrvrv.dll:infotec_2105.ppd:cupsui.dll:cups.hlp:NT
RAW:NULL"'
cmd = adddriver "Windows NT x86" "infotec_2105:cupsdrvrv.dll:infotec_2105.ppd:cupsu
cups.hlp:NULL:RAW:NULL"
Printer Driver infotec_2105 successfully installed.

Running command: smbclient //localhost/print\$ -N -U'root%secret' -c 'mkdir WIN40;
/var/spool/cups/tmp/3e98bf2d333b5 WIN40/infotec_2105.PPD; put
/usr/share/cups/drivers/ADFONTS.MFM WIN40/ADFONTS.MFM;put
/usr/share/cups/drivers/ADOBEPS4.DRV WIN40/ADOBEPS4.DRV;put
/usr/share/cups/drivers/ADOBEPS4.HLP WIN40/ADOBEPS4.HLP;put
/usr/share/cups/drivers/DEFPRT2.PPD WIN40/DEFPRT2.PPD;put
/usr/share/cups/drivers/ICONLIB.DLL
WIN40/ICONLIB.DLL;put /usr/share/cups/drivers/PSMON.DLL WIN40/PSMON.DLL;'
added interface ip=10.160.51.60 bcast=10.160.51.255 nmask=255.255.252.0
Domain=[CUPS-PRINT] OS=[Unix] Server=[Samba 2.2.7a]
NT_STATUS_OBJECT_NAME_COLLISION making remote directory \WIN40
```

```
putting file /var/spool/cups/tmp/3e98bf2d333b5 as \WIN40/infotec_2105.PPD (2328.8 kb/s)
(average 2328.8 kb/s)
putting file /usr/share/cups/drivers/ADFFONTS.MFM as \WIN40/ADFFONTS.MFM (9368.0 kb/s)
(average 6469.6 kb/s)
putting file /usr/share/cups/drivers/ADOBEPS4.DRV as \WIN40/ADOBEPS4.DRV (9958.2 kb/s)
(average 8404.3 kb/s)
putting file /usr/share/cups/drivers/ADOBEPS4.HLP as \WIN40/ADOBEPS4.HLP (8341.5 kb/s)
(average 8398.6 kb/s)
putting file /usr/share/cups/drivers/DEFPRTR2.PPD as \WIN40/DEFPRTR2.PPD (2195.9 kb/s)
(average 8254.3 kb/s)
putting file /usr/share/cups/drivers/ICONLIB.DLL as \WIN40/ICONLIB.DLL (8239.9 kb/s)
(average 8253.6 kb/s)
putting file /usr/share/cups/drivers/PSMON.DLL as \WIN40/PSMON.DLL (6222.2 kb/s)
(average 8188.5 kb/s)
```

```
Running command: rpcclient localhost -N -U'root%secret' -c 'adddriver "Windows 4.0"
"infotec_2105:ADOBEPS4.DRV:infotec_2105.PPD:NULL:ADOBEPS4.HLP:
PSMON.DLL:RAW:ADOBEPS4.DRV,infotec_2105.PPD,ADOBEPS4.HLP,PSMON.DLL,
ADFFONTS.MFM,DEFPRTR2.PPD,ICONLIB.DLL"'
cmd = adddriver "Windows 4.0" "infotec_2105:ADOBEPS4.DRV:infotec_2105.PPD:NULL:
ADOBEPS4.HLP:PSMON.DLL:RAW:ADOBEPS4.DRV,infotec_2105.PPD,ADOBEPS4
PSMON.DLL,ADFFONTS.MFM,DEFPRTR2.PPD,ICONLIB.DLL"
Printer Driver infotec_2105 successfully installed.
```

```
Running command: rpcclient localhost -N -U'root%secret'
-c 'setdriver infotec_2105 infotec_2105'
cmd = setdriver infotec_2105 infotec_2105
Sucesfully set infotec_2105 to driver infotec_2105.
```

If you look closely, you'll discover your root password was transferred unencrypted over the wire, so beware! Also, if you look further her, you'll discover error messages like `NT_STATUS_OBJECT_NAME_COLLISION` in between. They occur, because the directories `WIN40` and `W32X86` already existed in the `[print$]` driver download share (from a previous driver installation). They are harmless here.

19.10.11. Understanding cupsaddsmb

What has happened? What did `cupsaddsmb` do? There are five stages of the procedure

1. call the CUPS server via IPP and request the driver files and the PPD file for the named printer;
2. store the files temporarily in the local `TEMPDIR` (as defined in `cupsd.conf`);
3. connect via `smbclient` to the Samba server's `[print$]` share and put the files into the share's `WIN40` (for Win95/98/ME) and `W32X86/` (for WinNT/2k/XP) sub directories;
4. connect via `rpcclient` to the Samba server and execute the "adddriver" command with the correct parameters;
5. connect via `rpcclient` to the Samba server a second time and execute the "setdriver" command.

Note, that you can run the `cupsaddsmb` utility with parameters to specify one remote host as Samba host and a second remote host as CUPS host. Especially if

you want to get a deeper understanding, it is a good idea try it and see more clearly what is going on (though in real life most people will have their CUPS and Samba servers run on the same host):

```
# cupsaddsmb -H sambaserver -h cupsserver -v printername
```

19.10.12. How to recognize if cupsaddsm completed successfully

You *must* always check if the utility completed successfully in all fields. You need as a minimum these 3 messages amongst the output:

1. *Printer Driver infotec_2105 successfully installed.* # (for the W32X86 == WinNT/2K/XP architecture...)
2. *Printer Driver infotec_2105 successfully installed.* # (for the WIN40 == Win9x/ME architecture...)
3. *Successfully set [printerXPZ] to driver [printerXYZ].*

These messages probably not easily recognized in the general output. If you run cupsaddsmb with the -a parameter (which tries to prepare *all* active CUPS printer drivers for download), you might miss if individual printers drivers had problems to install properly. Here a redirection of the output will help you analyze the results in retrospective.

NOTE



It is impossible to see any diagnostic output if you don't run cupsaddsmb in verbose mode. Therefore we strongly recommend to not use the default quiet mode. It will hide any problems from you which might occur.

19.10.13. cupsaddsmb with a Samba PDC

You can't get the standard cupsaddsmb command to run on a Samba PDC? You are asked for the password credential all over again and again and the command just will not take off at all? Try one of these variations:

```
# cupsaddsmb -U DOMAINNAME\\root -v printername
# cupsaddsmb -H SAMBA-PDC -U DOMAINNAME\\root -v printername
# cupsaddsmb -H SAMBA-PDC -U DOMAINNAME\\root -h cups-server -v printername
```

(Note the two backslashes: the first one is required to "escape" the second one).

19.10.14. cupsaddsmb Flowchart

Here is a chart about the procedures, commandflows and dataflows of the "cupsaddsmb" command. Note again: cupsaddsmb is not intended to, and does not work with, "raw" queues!

19.10.15. Installing the PostScript Driver on a Client

After `cupsaddsmb` completed, your driver is prepared for the clients to use. Here are the steps you must perform to download and install it via "Point'n'Print". From a Windows client, browse to the CUPS/Samba server;

- open the *Printers* share of Samba in Network Neighbourhood;
- right-click on the printer in question;
- from the opening context-menu select *Install...* or *Connect...* (depending on the Windows version you use).

After a few seconds, there should be a new printer in your client's *local* "Printers" folder: On Windows XP it will follow a naming convention of *PrinterName on SambaServer*. (In my current case it is "infotec.2105 on kde-bitshop"). If you want to test it and send your first job from an application like Winword, the new printer will appear in a `\\SambaServer\PrinterName` entry in the dropdown list of available printers.

NOTE



`cupsaddsmb` will only reliably work with CUPS version 1.1.15 or higher and Samba from 2.2.4. If it doesn't work, or if the automatic printer driver download to the clients doesn't succeed, you can still manually install the CUPS printer PPD on top of the Adobe PostScript driver on clients. Then point the client's printer queue to the Samba printer share for a UNC type of connection:

```
net use lpt1: \\sambaserver\printershare /user:ntadmin
```

should you desire to use the CUPS networked PostScript RIP functions. (Note that user "ntadmin" needs to be a valid Samba user with the required privileges to access the printers share) This would set up the printer connection in the traditional *LanMan* way (not using MS-RPC).

19.10.16. Avoiding critical PostScript Driver Settings on the Client

Soooo: printing works, but there are still problems. Most jobs print well, some don't print at all. Some jobs have problems with fonts, which don't look very good. Some jobs print fast, and some are dead-slow. Many of these problems can be greatly reduced or even completely eliminated if you follow a few guidelines. Remember, if your print device is not PostScript-enabled, you are treating your Ghostscript installation on your CUPS host with the output your client driver settings produce. Treat it well:

- Avoid the *PostScript Output Option: Optimize for Speed* setting. Rather use the *Optimize for Portability* instead (Adobe PostScript driver).
- Don't use the *Page Independence: NO* setting. Instead use *Page Independence YES* (CUPS PostScript Driver)
- Recommended is the *True Type Font Downloading Option: Native True Type* over *Automatic* and *Outline*; you should by all means avoid *Bitmap* (Adobe

- PostScript Driver)
- Choose *True Type Font: Download as Softfont into Printer* over the default *Replace by Device Font* (for exotic fonts you may need to change it back to get a printout at all) (Adobe)
- Sometimes you can choose *PostScript Language Level*: in case of problems try 2 instead of 3 (the latest ESP Ghostscript package handles Level 3 PostScript very well) (Adobe).
- Say *Yes* to *PostScript Error Handler* (Adobe)

19.11. Installing PostScript Driver Files manually (using `rpcclient`)

Of course you can run all the commands which are embedded into the `cupsaddsmb` convenience utility yourself, one by one, and hereby upload and prepare the driver files for future client downloads.

1. prepare Samba (a CUPS printqueue with the name of the printer should be there. We are providing the driver now);
2. copy all files to `[print$]`;
3. run **`rpcclient adddriver`** (for each client architecture you want to support):
4. run **`rpcclient setdriver`**.

We are going to do this now. First, read the man page on "rpcclient" to get a first idea. Look at all the printing related sub-commands. **`enumprinters`**, **`enumdrivers`**, **`enumports`**, **`adddriver`**, **`setdriver`** are amongst the most interesting ones. `rpcclient` implements an important part of the MS-RPC protocol. You can use it to query (and command) a Win NT (or 2K/XP) PC too. MS-RPC is used by Windows clients, amongst other things, to benefit from the "Point'n' Print" features. Samba can now mimic this too.

19.11.1. A Check of the `rpcclient` man Page

First let's have a little check of the `rpcclient` man page. Here are two relevant passages:

`adddriver` `<arch>` `<config>` Execute an `AddPrinterDriver()` RPC to install the printer driver information on the server. Note that the driver files should already exist in the directory returned by **`getdriverdir`**. Possible values for `arch` are the same as those for the **`getdriverdir`** command. The `config` parameter is defined as follows:

```
Long Printer Name:\
Driver File Name:\
Data File Name:\
Config File Name:\
Help File Name:\
Language Monitor Name:\
Default Data Type:\
Comma Separated list of Files
```

Any empty fields should be enter as the string "NULL".

Samba does not need to support the concept of Print Monitors since these only apply to local printers whose driver can make use of a bi-directional link for communication. This field should be "NULL". On a remote NT print server, the Print

Monitor for a driver must already be installed prior to adding the driver or else the RPC will fail

setdriver <printername> <drivername> Execute a **SetPrinter()** command to update the printer driver associated with an installed printer. The printer driver must already be correctly installed on the print server.

See also the `enumprinters` and `enumdrivers` commands for obtaining a list of installed printers and drivers.

19.11.2. Understanding the `rpcclient` man Page

The *exact* format isn't made too clear by the man page, since you have to deal with some parameters containing spaces. Here is a better description for it. We have line-broken the command and indicated the breaks with "\". Usually you would type the command in one line without the linebreaks:

```
adddriver "Architecture" \  
    "LongPrinterName:DriverFile:DataFile:ConfigFile:HelpFile:\  
    LanguageMonitorFile:DataType:ListOfFiles,Comma-separated"
```

What the man pages denotes as a simple <config> keyword, does in reality consist of 8 colon-separated fields. The last field may take multiple (in some, very insane, cases, even 20 different additional files. This might sound confusing at first. Note, that what the man pages names the "LongPrinterName" in reality should rather be called the "Driver Name". You can name it anything you want, as long as you use this name later in the `rpcclient ... setdriver` command. For practical reasons, many name the driver the same as the printer.

True: it isn't simple at all. I hear you asking: *How do I know which files are "Driver File", "Data File", "Config File", "Help File" and "Language Monitor File" in each case?* – For an answer you may want to have a look at how a Windows NT box with a shared printer presents the files to us. Remember, that this whole procedure has to be developed by the Samba Team by overhearing the traffic caused by Windows computers on the wire. We may as well turn to a Windows box now, and access it from a UNIX workstation. We will query it with **rpcclient** to see what it tells us and try to understand the man page more clearly which we've read just now.

19.11.3. Producing an Example by querying a Windows Box

We could run **rpcclient** with a **getdriver** or a **getprinter** subcommand (in level 3 verbosity) against it. Just sit down at UNIX or Linux workstation with the Samba utilities installed. Then type the following command:

```
rpcclient -U'USERNAME%PASSWORD' NT-SERVER-NAME -c 'getdriver printername 3'
```

From the result it should become clear which is which. Here is an example from my installation:

```
# rpcclient -U'Danka%xxxx' W2KSERVER -c'getdriver "DANKA InfoStream Virtual Printer"
cmd = getdriver "DANKA InfoStream Virtual Printer" 3
```

```
[Windows NT x86]
```

```
Printer Driver Info 3:
```

```
Version: [2]
```

```
Driver Name: [DANKA InfoStream]
```

```
Architecture: [Windows NT x86]
```

```
Driver Path: [C:\WINNT\System32\spool\DRIVERS\W32X86\2\PSCRIPT.DLL]
```

```
Datafile: [C:\WINNT\System32\spool\DRIVERS\W32X86\2\INFOSTRM.PPD]
```

```
Configfile: [C:\WINNT\System32\spool\DRIVERS\W32X86\2\PSCRPTUI.DLL]
```

```
Helpfile: [C:\WINNT\System32\spool\DRIVERS\W32X86\2\PSCRIPT.HLP]
```

```
Dependentfiles: []
```

```
Dependentfiles: []
```

```
Dependentfiles: []
```

```
Dependentfiles: []
```

```
Dependentfiles: []
```

```
Dependentfiles: []
```

```
Dependentfiles: []
```

```
Monitorname: []
```

```
Defaultdatatype: []
```

Some printer drivers list additional files under the label "Dependentfiles": these would go into the last field *ListOfFiles,Comma-separated*. For the CUPS PostScript drivers we don't need any (nor would we for the Adobe PostScript driver): therefore the field will get a "NULL" entry.

19.11.4. What is required for `adddriver` and `setdriver` to succeed

From the manpage (and from the quoted output of `ofcupsaddsmb`, above) it becomes clear that you need to have certain conditions in order to make the manual uploading and initializing of the driver files succeed. The two `rpcclient` subcommands (`adddriver` and `setdriver`) need to encounter the following pre-conditions to complete successfully:

- you are connected as "printer admin", or root (note, that this is *not* the "Printer Operators" group in NT, but the *printer admin* group, as defined in the [global] section of `smb.conf`);
- copy all required driver files to `\\sambaserver\print$\w32x86` and `\\sambaserver\print$\win` as appropriate. They will end up in the "0" respective "2" subdirectories later – for now *don't* put them there, they'll be automatically used by the `adddriver` subcommand! (if you use "smbclient" to put the driver files into the share, note that you need to escape the "\$": `smbclient //sambaserver/print/$ -U root`);
- the user you're connecting as must be able to write to the [print\$] share and create subdirectories;
- the printer you are going to setup for the Windows clients, needs to be installed in CUPS already;
- the CUPS printer must be known to Samba, otherwise the `setdriver` subcommand fails with an `NT_STATUS_UNSUCCESSFUL` error. To check if the

printer is known by Samba you may use the **enumprinters** subcommand to `rpcclient`. A long-standing bug prevented a proper update of the printer list until every `smbd` process had received a `SIGHUP` or was restarted. Remember this in case you've created the CUPS printer just shortly ago and encounter problems: try restarting Samba.

19.11.5. Manual Commandline Driver Installation in 15 little Steps

We are going to install a printer driver now by manually executing all required commands. As this may seem a rather complicated process at first, we go through the procedure step by step, explaining every single action item as it comes up.

19.11.5.1. First Step: Install the Printer on CUPS

```
# lpadmin -p mysmbtstprn -v socket://10.160.51.131:9100 -E -P /home/kurt/canonIR85.p
```

This installs printer with the name *mysmbtstprn* to the CUPS system. The printer is accessed via a socket (a.k.a. JetDirect or Direct TCP/IP) connection. You need to be root for this step

19.11.5.2. Second Step (optional): Check if the Printer is recognized by Samba

```
# rpcclient -Uroot%xxxx -c 'enumprinters' localhost | grep -C2 mysmbtstprn

flags: [0x800000]
name: [\\kde-bitshop\mysmbtstprn]
description: [\\kde-bitshop\mysmbtstprn,,mysmbtstprn]
comment: [mysmbtstprn]
```

This should show the printer in the list. If not, stop and re-start the Samba daemon (`smbd`), or send a HUP signal: **kill -HUP 'pidof smbd'**. Check again. Troubleshoot and repeat until success. Note the "empty" field between the two commas in the "description" line. Here would the driver name appear if there was one already. You need to know root's Samba password (as set by the **smbpasswd** command) for this step and most of the following steps. Alternatively you can authenticate as one of the users from the "write list" as defined in `smb.conf` for `[print$]`.

19.11.5.3. Third Step (optional): Check if Samba knows a Driver for the Printer

```
# rpcclient -Uroot%xxxx -c 'getprinter mysmbtstprn 2' localhost | grep driver
drivername: []

# rpcclient -Uroot%xxxx -c 'getprinter mysmbtstprn 2' localhost | grep -C4 driv
```

```
servername: [\\kde-bitshop]
printername: [\\kde-bitshop\mysmbtstprn]
sharename: [mysmbtstprn]
portname: [Samba Printer Port]
drivername: []
comment: [mysmbtstprn]
location: []
sepfile: []
printprocessor: [winprint]

# rpcclient -U root%xxxx -c 'getdriver mysmbtstprn' localhost
result was WERR_UNKNOWN_PRINTER_DRIVER
```

Neither method of the three commands shown above should show a driver. This step was done for the purpose of demonstrating this condition. An attempt to connect to the printer at this stage will prompt the message along the lines: "The server has not the required printer driver installed".

19.11.5.4. Fourth Step: Put all required Driver Files into Samba's [print\$]

```
# smbclient //localhost/print\$ -U 'root%xxxx' \
-c 'cd W32X86;
put /etc/cups/ppd/mysmbtstprn.ppd mysmbtstprn.PPD;
put /usr/share/cups/drivers/cupsui.dll cupsui.dll;
put /usr/share/cups/drivers/cupsdrv.dll cupsdrv.dll;
put /usr/share/cups/drivers/cups.hlp cups.hlp'
```

(Note that this command should be entered in one long single line. Line-breaks and the line-end indicating "\" has been inserted for readability reasons.) This step is *required* for the next one to succeed. It makes the driver files physically present in the [print\$] share. However, clients would still not be able to install them, because Samba does not yet treat them as driver files. A client asking for the driver would still be presented with a "not installed here" message.

19.11.5.5. Fifth Step: Verify where the Driver Files are now

```
# ls -l /etc/samba/drivers/W32X86/
total 669
drwxr-sr-x  2 root    ntadmin    532 May 25 23:08 2
drwxr-sr-x  2 root    ntadmin    670 May 16 03:15 3
-rwxr--r--  1 root    ntadmin   14234 May 25 23:21 cups.hlp
-rwxr--r--  1 root    ntadmin  278380 May 25 23:21 cupsdrv.dll
-rwxr--r--  1 root    ntadmin  215848 May 25 23:21 cupsui.dll
-rwxr--r--  1 root    ntadmin  169458 May 25 23:21 mysmbtstprn.PPD
```

The driver files now are in the W32X86 architecture "root" of [print\$].

19.11.5.6. Sixth Step: Tell Samba that these are Driver Files (adddriver)

```
# rpcclient -Uroot%xxxx -c 'adddriver "Windows NT x86" "mydrivename: \  
                                cupsdrv.dll:mysmbtstprn.PPD:  
                                cupsui.dll:cups.hlp:NULL:RAW:NULL"  
                                localhost
```

Printer Driver mydrivename successfully installed.

Note that you cannot repeat this step if it fails. It could fail even as a result of a simple typo. It will most likely have moved a part of the driver files into the "2" subdirectory. If this step fails, you need to go back to the fourth step and repeat it, before you can try this one again. In this step you need to choose a name for your driver. It is normally a good idea to use the same name as is used for the printername; however, in big installations you may use this driver for a number of printers which have obviously different names. So the name of the driver is not fixed.

19.11.5.7. Seventh Step: Verify where the Driver Files are now

```
# ls -l /etc/samba/drivers/W32X86/  
total 1  
drwxr-sr-x  2 root    ntadmin    532 May 25 23:22 2  
drwxr-sr-x  2 root    ntadmin    670 May 16 03:15 3  
  
# ls -l /etc/samba/drivers/W32X86/2  
total 5039  
[...]  
-rwxr--r--  1 root    ntadmin    14234 May 25 23:21 cups.hlp  
-rwxr--r--  1 root    ntadmin    278380 May 13 13:53 cupsdrv.dll  
-rwxr--r--  1 root    ntadmin    215848 May 13 13:53 cupsui.dll  
-rwxr--r--  1 root    ntadmin    169458 May 25 23:21 mysmbtstprn.PPD
```

Notice how step 6 did also move the driver files to the appropriate subdirectory. Compare with the situation after step 5.

19.11.5.8. Eighth Step (optional): Verify if Samba now recognizes the Driver

```
# rpcclient -Uroot%xxxx -c 'enumdrivers 3' localhost | grep -B2 -A5 mydrivename
```

```
Printer Driver Info 3:  
  Version: [2]  
  Driver Name: [mydrivename]  
  Architecture: [Windows NT x86]  
  Driver Path: [\\kde-bitshop\print$\W32X86\2\cupsdrv.dll]
```

```
Datafile: [\\kde-bitshop\print$\W32X86\2\mysmbtstprn.PPD]
Configfile: [\\kde-bitshop\print$\W32X86\2\cupsui.dll]
Helpfile: [\\kde-bitshop\print$\W32X86\2\cups.hlp]
```

Remember, this command greps for the name you did choose for the driver in step Six. This command must succeed before you can proceed.

19.11.5.9. Ninth Step: Tell Samba which Printer should use these Driver Files (setdriver)

```
# rpcclient -Uroot%xxxx -c 'setdriver mysmbtstprn mydrivename' localhost
```

```
Successfully set mysmbtstprn to driver mydrivename
```

Since you can bind any printername (=printqueue) to any driver, this is a very convenient way to setup many queues which use the same driver. You don't need to repeat all the previous steps for the setdriver command to succeed. The only pre-conditions are: **enumdrivers** must find the driver and **enumprinters** must find the printer.

19.11.5.10. Tenth Step (optional): Verify if Samba has this Association recognized

```
# rpcclient -Uroot%xxxx -c 'getprinter mysmbtstprn 2' localhost | grep driver
  drivename:[mydrivename]

# rpcclient -Uroot%xxxx -c 'getprinter mysmbtstprn 2' localhost | grep -C4 driv
  servername:[\\kde-bitshop]
  printername:[\\kde-bitshop\mysmbtstprn]
  sharename:[mysmbtstprn]
  portname:[Done]
  drivename:[mydrivename]
  comment:[mysmbtstprn]
  location:[]
  sepfile:[]
  printprocessor:[winprint]

# rpcclient -U root%xxxx -c 'getdriver mysmbtstprn' localhost
[Windows NT x86]
Printer Driver Info 3:
  Version: [2]
  Driver Name: [mydrivename]
  Architecture: [Windows NT x86]
  Driver Path: [\\kde-bitshop\print$\W32X86\2\cupsdrv.dll]
  Datafile: [\\kde-bitshop\print$\W32X86\2\mysmbtstprn.PPD]
  Configfile: [\\kde-bitshop\print$\W32X86\2\cupsui.dll]
  Helpfile: [\\kde-bitshop\print$\W32X86\2\cups.hlp]
```

```
Monitorname: []
Defaultdatatype: [RAW]
Monitorname: []
Defaultdatatype: [RAW]

# rpcclient -Uroot%xxxx -c 'enumprinters' localhost | grep mysmbtstprn
name:[\\kde-bitshop\mysmbtstprn]
description:[\\kde-bitshop\mysmbtstprn,mydrivername,mysmbtstprn]
comment:[mysmbtstprn]
```

Compare these results with the ones from steps 2 and 3. Note that every single of these commands show the driver is installed. Even the **enumprinters** command now lists the driver on the "description" line.

19.11.5.11. Eleventh Step (optional): Tickle the Driver into a correct Device Mode

You certainly know how to install the driver on the client. In case you are not particularly familiar with Windows, here is a short recipe: browse the Network Neighbourhood, go to the Samba server, look for the shares. You should see all shared Samba printers. Double-click on the one in question. The driver should get installed, and the network connection set up. An alternative way is to open the "Printers (and Faxes)" folder, right-click on the printer in question and select "Connect" or "Install". As a result, a new printer should have appeared in your client's local "Printers (and Faxes)" folder, named something like "printersharename on Sambahostname".

It is important that you execute this step as a Samba printer admin (as defined in `smb.conf`). Here is another method to do this on Windows XP. It uses a commandline, which you may type into the "DOS box" (type root's smbpassword when prompted):

```
C:\> runas /netonly /user:root "rundll32 printui.dll,PrintUIEntry /in /n \\sambacup
```

Change any printer setting once (like "portrait" -> "landscape"), click "Apply"; change the setting back.

19.11.5.12. Twelveth Step: Install the Printer on a Client ("Point'n'Print")

```
C:\> rundll32 printui.dll,PrintUIEntry /in /n "\\sambacupserver\mysmbtstprn"
```

If it doesn't work it could be a permission problem with the [print\$] share.

19.11.5.13. Thirteenth Step (optional): Print a Test Page

```
C:\> rundll32 printui.dll,PrintUIEntry /p /n "\\sambacupserver\mysmbtstprn"
```

Then hit [TAB] 5 times, [ENTER] twice, [TAB] once and [ENTER] again and march to the printer.

19.11.5.14. Fourteenth Step (recommended): Study the Test Page

Hmmm.... just kidding! By now you know everything about printer installations and you don't need to read a word. Just put it in a frame and bolt it to the wall with the heading "MY FIRST RPCCLIENT-INSTALLED PRINTER" - why not just throw it away!

19.11.5.15. Fifteenth Step (obligatory): Enjoy. Jump. Celebrate your Success

```
# echo "Cheeeeeerioooooo! Success..." >> /var/log/samba/log.smbd
```

19.11.6. Troubleshooting revisited

The setdriver command will fail, if in Samba's mind the queue is not already there. You had promising messages about the:

```
Printer Driver ABC successfully installed.
```

after the "adddriver" parts of the procedure? But you are also seeing a disappointing message like this one beneath?

```
result was NT_STATUS_UNSUCCESSFUL
```

It is not good enough that *you* can see the queue *in CUPS*, using the `lpstat -p ir85wm` command. A bug in most recent versions of Samba prevents the proper update of the queuelist. The recognition of newly installed CUPS printers fails unless you re-start Samba or send a HUP to all smbd processes. To verify if this is the reason why Samba doesn't execute the setdriver command successfully, check if Samba "sees" the printer:

```
# rpcclient transmeta -N -U'root%secret' -c 'enumprinters 0' | grep ir85wm
printername:[ir85wm]
```

An alternative command could be this:

```
# rpcclient transmeta -N -U'root%secret' -c 'getprinter ir85wm'
```



```
cmd = getprinter ir85wm
flags: [0x800000]
name: [\\transmeta\ir85wm]
description: [\\transmeta\ir85wm,ir85wm,DPD]
comment: [CUPS PostScript-Treiber for WinNT/2K/XP]
```

BTW, you can use these commands, plus a few more, of course, to install drivers on remote Windows NT print servers too!

19.12. The printing *.tdb Files

Some mystery is associated with the series of files with a tdb-suffix appearing in every Samba installation. They are `connections.tdb`, `printing.tdb`, `share_info.tdb`, `ntdrivers.tdb`, `unexpected.tdb`, `brlock.tdb`, `locking.tdb`, `ntforms.tdb`, `messages.tdb`, `ntprinters.tdb`, `sessionid.tdb` and `secrets.tdb`. What is their purpose?

19.12.1. Trivial DataBase Files

A Windows NT (Print) Server keeps track of all information needed to serve its duty toward its clients by storing entries in the Windows "Registry". Client queries are answered by reading from the registry, Administrator or user configuration settings are saved by writing into the Registry. Samba and Unix obviously don't have such a kind of Registry. Samba instead keeps track of all client related information in a series of *.tdb files. (TDB = Trivial Data Base). These are often located in `/var/lib/samba/` or `/var/lock/samba/`. The printing related files are `ntprinters.tdb`, `printing.tdb`, `ntforms.tdb` and `ntdrivers.tdb`.

19.12.2. Binary Format

*.tdb files are not human readable. They are written in a binary format. "Why not ASCII?", you may ask. "After all, ASCII configuration files are a good and proofed tradition on UNIX." – The reason for this design decision by the Samba Team is mainly performance. Samba needs to be fast; it runs a separate `smbd` process for each client connection, in some environments many thousand of them. Some of these `smbds` might need to write-access the same *.tdb file *at the same time*. The file format of Samba's *.tdb files allows for this provision. Many `smbd` processes may write to the same *.tdb file at the same time. This wouldn't be possible with pure ASCII files.

19.12.3. Losing *.tdb Files

It is very important that all *.tdb files remain consistent over all write and read accesses. However, it may happen that these files *do* get corrupted. (A `kill -9 'pidof smbd'` while a write access is in progress could do the damage as well as a power interruption, etc.). In cases of trouble, a deletion of the old printing-related *.tdb files may be the only option. You need to re-create all print related setup after that. Or you have made a backup of the *.tdb files in time.

19.12.4. Using tdbbackup

Samba ships with a little utility which helps the root user of your system to back up your *.tdb files. If you run it with no argument, it prints a little usage message:

```
# tdbbackup
Usage: tdbbackup [options] <fname...>

Version:3.0a
  -h          this help message
  -s suffix   set the backup suffix
  -v          verify mode (restore if corrupt)
```

Here is how I backed up my printing.tdb file:

```
# ls
.          browse.dat      locking.tdb      ntdrivers.tdb   printing.tdb    share_
..         connections.tdb messages.tdb     ntforms.tdb     printing.tdbkp  unexpe
brlock.tdb gmon.out        namelist.debug  ntprinters.tdb  sessionid.tdb

kde-bitshop:/var/lock/samba # tdbbackup -s .bak printing.tdb
printing.tdb : 135 records

kde-bitshop:/var/lock/samba # ls -l printing.tdb*
-rw-----  1 root    root      40960 May  2 03:44 printing.tdb
-rw-----  1 root    root      40960 May  2 03:44 printing.tdb.bak
```

19.13. CUPS Print Drivers from Linuxprinting.org

CUPS ships with good support for HP LaserJet type printers. You can install the generic driver as follows:

```
lpadmin -p laserjet4plus -v parallel:/dev/lp0 -E -m laserjet.ppd
```

The -m switch will retrieve the `laserjet.ppd` from the standard repository for not-yet-installed-PPDs, which CUPS typically stores in `/usr/share/cups/model`. Alternatively, you may use `-P /path/to/your.ppd`.

The generic `laserjet.ppd` however does not support every special option for every LaserJet-compatible model. It constitutes a sort of "least denominator" of all the models. If for some reason it is ruled out to you to pay for the commercially available ESP Print Pro drivers, your first move should be to consult the database on http://www.linuxprinting.org/printer_list.cgi. Linuxprinting.org has excellent recommendations about which driver is best used for each printer. Its database is kept current by the tireless work of Till Kamppeter from MandrakeSoft, who is also the principal author of the `foomatic-rip` utility.

NOTE



The former "cupsomatic" concept is now be replaced by the new, much more powerful "foomatic-rip". foomatic-rip is the successor of cupsomatic. cupsomatic is no longer maintained. Here is the new URL to the Foomatic-3.0 database:http://www.linuxprinting.org/driver_list.cgi. If you upgrade to foomatic-rip, don't forget to also upgrade to the new-style PPDs for your foomatic-driven printers. foomatic-rip will not work with PPDs generated for the old cupsomatic. The new-style PPDs are 100% compliant to the Adobe PPD specification. They are intended to be used by Samba and the cupsaddsmb utility also, to provide the driver files for the Windows clients also!

19.13.1. foomatic-rip and Foomatic explained

Nowadays most Linux distros rely on the utilities of Linuxprinting.org to create their printing related software (which, BTW, works on all UNIXes and on Mac OS X or Darwin too). It is not known as well as it should be, that it also has a very end-user friendly interface which allows for an easy update of drivers and PPDs, for all supported models, all spoolers, all operating systems and all package formats (because there is none). Its history goes back a few years.

Recently Foomatic has achieved the astonishing milestone of [1000 listed](#) printer models. Linuxprinting.org keeps all the important facts about printer drivers, supported models and which options are available for the various driver/printer combinations in its [Foomatic](#) database. Currently there are [245 drivers](#) in the database: many drivers support various models, and many models may be driven by different drivers; it's your choice!

19.13.1.1. 690 "perfect" Printers

At present there are 690 devices dubbed as working "perfectly", 181 "mostly", 96 "partially" and 46 are "Paperweights". Keeping in mind that most of these are non-PostScript models (PostScript printers are automatically supported supported by CUPS to perfection, by using their own manufacturer-provided Windows-PPD...), and that a multifunctional device never qualifies as working "perfectly" if it doesn't also scan and copy and fax under GNU/Linux: then this is a truly astonishing achievement. Three years ago the number was not more than 500, and Linux or UNIX "printing" at the time wasn't anywhere near the quality it is today!

19.13.1.2. How the "Printing HOWTO" started it all

A few years ago [Grant Taylor](#) started it all. The roots of today's Linuxprinting.org are in the first [Linux Printing HOWTO](#) which he authored. As a side-project to this document, which served many Linux users and admins to guide their first steps in this complicated and delicate setup (to a scientist, printing is "applying a structured deposition of distinct patterns of ink or toner particles on paper substrates" ;-), he started to build in a little Postgres database with information about the hardware and driver zoo that made up Linux printing of the time. This database became the

core component of today's Foomatic collection of tools and data. In the meantime it has moved to an XML representation of the data.

19.13.1.3. Foomatic's strange Name

"Why the funny name?", you ask. When it really took off, around spring 2000, CUPS was far less popular than today, and most systems used LPD, LPRng or even PDQ to print. CUPS shipped with a few generic "drivers" (good for a few hundred different printer models). These didn't support many device-specific options. CUPS also shipped with its own built-in rasterization filter ("pstoraster", derived from Ghostscript). On the other hand, CUPS provided brilliant support for *controlling* all printer options through standardized and well-defined "PPD files" (PostScript Printers Description files). Plus, CUPS was designed to be easily extensible.

Grant already had in his database a respectable compilation of facts about a many more printers, and the Ghostscript "drivers" they run with. His idea, to generate PPDs from the database info and use them to make standard Ghostscript filters work within CUPS, proved to work very well. It also "killed several birds with one stone":

- It made all current and future Ghostscript filter developments available for CUPS;
- It made available a lot of additional printer models to CUPS users (because often the "traditional" Ghostscript way of printing was the only one available);
- It gave all the advanced CUPS options (web interface, GUI driver configurations) to users wanting (or needing) to use Ghostscript filters.

19.13.1.4. cupsomatic, pdqomatic, lpdomatic, directomatic

CUPS worked through a quickly-hacked up filter script named [cupsomatic](#). [cupsomatic](#) ran the printfile through Ghostscript, constructing automatically the rather complicated command line needed. It just required to be copied into the CUPS system to make it work. To "configure" the way [cupsomatic](#) controls the Ghostscript rendering process, it needs a CUPS-PPD. This PPD is generated directly from the contents of the database. For CUPS and the respective printer/filter combo another Perl script named "CUPS-O-Matic" did the PPD generation. After that was working, Grant implemented within a few days a similar thing for two other spoolers. Names chosen for the config-generator scripts were [PDQ-O-Matic](#) (for PDQ) and [LPD-O-Matic](#) (for - you guessed it - LPD); the configuration here didn't use PPDs but other spooler-specific files.

From late summer of that year, [Till Kamppeter](#) started to put work into the database. Till had been newly employed by [MandrakeSoft](#) to convert their printing system over to CUPS, after they had seen his [FLTK](#)-based [XPP](#) (a GUI frontend to the CUPS `lp-command`). He added a huge amount of new information and new printers. He also developed the support for other spoolers, like [PPR](#) (via [ppromatic](#)), [GNUlpr](#) and [LPRng](#) (both via an extended [lpdomatic](#)) and "spoolerless" printing ([directomatic](#))...

So, to answer your question: "Foomatic" is the general name for all the overlapping code and data behind the "*omatic" scripts... – Foomatic up to versions 2.0.x required (ugly) Perl data structures attached the [Linuxprinting.org](#) PPDs for CUPS. It had a different "*omatic" script for every spooler, as well as different printer configuration files..

19.13.1.5. 7.13.1.5.The Grand Unification achieved...

This all has changed in Foomatic versions 2.9 (Beta) and released as "stable" 3.0. This has now achieved the convergence of all *omatic scripts: it is called the [foomatic-rip](#). This single script is the unification of the previously different spooler-specific *omatic scripts. [foomatic-rip](#) is used by all the different spoolers alike. Because [foomatic-rip](#) can read PPDs (both the original PostScript printer PPDs and the Linuxprinting.org-generated ones), all of a sudden all supported spoolers can have the power of PPDs at their disposal; users only need to plug "foomatic-rip" into their system.... For users there is improved media type and source support; paper sizes and trays are easier to configure.

Also, the New Generation of Linuxprinting.org PPDs doesn't contain Perl data structures any more. If you are a distro maintainer and have used the previous version of Foomatic, you may want to give the new one a spin: but don't forget to generate a new-version set of PPDs, via the new [foomatic-db-engine](#)! Individual users just need to generate a single new PPD specific to their model by [following the steps](#) outlined in the Foomatic tutorial or further below. This new development is truly amazing.

[foomatic-rip](#) is a very clever wrapper around the need to run Ghostscript with a different syntax, different options, different device selections and/or different filters for each different printer or different spooler. At the same time it can read the PPD associated with a print queue and modify the print job according to the user selections. Together with this comes the 100% compliance of the new Foomatic PPDs with the Adobe spec. Some really innovative features of the Foomatic concept will surprise users: it will support custom paper sizes for many printers; and it will support printing on media drawn from different paper trays within the same job (in both cases: even where there is no support for this from Windows-based vendor printer drivers).

19.13.1.6. Driver Development outside

Most driver development itself does not happen within Linuxprinting.org. Drivers are written by independent maintainers. Linuxprinting.org just pools all the information, and stores it in its database. In addition, it also provides the Foomatic glue to integrate the many drivers into any modern (or legacy) printing system known to the world.

Speaking of the different driver development groups: most of the work is currently done in three projects. These are:

- [Omni](#) – a Free Software project by IBM which tries to convert their printer driver knowledge from good-ol' OS/2 times into a modern, modular, universal driver architecture for Linux/Unix (still Beta). This currently supports 437 models.
- [HPIJS](#) – a Free Software project by HP to provide the support for their own range of models (very mature, printing in most cases is perfect and provides true photo quality). This currently supports 369 models.
- [Gimp-Print](#) – a Free software effort, started by Michael Sweet (also lead developer for CUPS), now directed by Robert Krawitz, which has achieved an amazing level of photo print quality (many Epson users swear that its quality is better than the vendor drivers provided by Epson for the Microsoft platforms). This currently supports 522 models.

19.13.1.7. Forums, Downloads, Tutorials, Howtos – also for Mac OS X and commercial Unix

Linuxprinting.org today is the one-stop "shop" to download printer drivers. Look for printer information and [tutorials](#) or solve printing problems in its popular [forums](#). But it's not just for GNU/Linux: users and admins of [commercial UNIX systems](#) are also going there, and the relatively new [Mac OS X forum](#) has turned out to be one of the most frequented fora after only a few weeks.

Linuxprinting.org and the Foomatic driver wrappers around Ghostscript are now a standard toolchain for printing on all the important distros. Most of them also have CUPS underneath. While in recent years most printer data had been added by Till (who works at Mandrake), many additional contributions came from engineers with SuSE, RedHat, Connectiva, Debian and others. Vendor-neutrality is an important goal of the Foomatic project.

NOTE



Till Kammeter from MandrakeSoft is doing an excellent job in his spare time to maintain Linuxprinting.org and Foomatic. So if you use it often, please send him a note showing your appreciation.

19.13.1.8. Foomatic Database generated PPDs

The Foomatic database is an amazing piece of ingenuity in itself. Not only does it keep the printer and driver information, but it is organized in a way that it can generate "PPD" files "on the fly" from its internal XML-based datasets. While these PPDs are modelled to the Adobe specification of "PostScript Printer Descriptions" (PPDs), the Linuxprinting.org/Foomatic-PPDs don't normally drive PostScript printers: they are used to describe all the bells and whistles you could ring or blow on an Epson Stylus inkjet, or a HP Photosmart or what-have-you. The main "trick" is one little additional line, not envisaged by the PPD specification, starting with the "*cupsFilter" keyword: it tells the CUPS daemon how to proceed with the PostScript print file (old-style Foomatic-PPDs named the *cupsomatic* filter script, while the new-style PPDs now call *foomatic-rip*). This filter script calls Ghostscript on the host system (the recommended variant is ESP Ghostscript) to do the rendering work. *foomatic-rip* knows which filter or internal device setting it should ask from Ghostscript to convert the PostScript printjob into a raster format ready for the target device. This usage of PPDs to describe the options of non-PS printers was the invention of the CUPS developers. The rest is easy: GUI tools (like KDE's marvellous "[kprinter](#)", or the GNOME "[gtklp](#)", "xpp" and the CUPS web interface) read the PPD too and use this information to present the available settings to the user as an intuitive menu selection.

19.13.2. *foomatic-rip* and Foomatic-PPD Download and Installation

Here are the steps to install a *foomatic-rip* driven "LaserJet 4 Plus" compatible printer in CUPS (note that recent distributions of SuSE, UnitedLinux and Mandrake may ship with a complete package of Foomatic-PPDs plus the *foomatic-rip* utility, going directly to Linuxprinting.org ensures you to get the latest driver/PPD files):

- Surf to http://www.linuxprinting.org/printer_list.cgi

- Check the complete list of printers in the database: http://www.linuxprinting.org/printer_list.cgi?make=Anyone
- There select your model and click on the link.
- You'll arrive at a page listing all drivers working with this model (for all printers, there will always be *one* recommended driver. Try this one first).
- In our case ("HP LaserJet 4 Plus"), we'll arrive here: http://www.linuxprinting.org/show_printer.cgi?recnum=HP-LaserJet_4_Plus
- The recommended driver is "ljet4".
- There are several links provided here. You should visit them all, if you are not familiar with the Linuxprinting.org database.
- There is a link to the database page for the "ljet4": http://www.linuxprinting.org/show_driver.cgi?driver=ljet4 On the driver's page, you'll find important and detailed information about how to use that driver within the various available spoolers.
- Another link may lead you to the homepage of the driver author or the driver.
- Important links are the ones which provide hints with setup instructions for CUPS (<http://www.linuxprinting.org/cups-doc.html>), PDQ (<http://www.linuxprinting.org/pdq-doc.html>), LPD, LPRng and GNUlpr (<http://www.linuxprinting.org/lpd-doc.html>) as well as PPR (<http://www.linuxprinting.org/ppr-doc.html>) or "spooler-less" printing (<http://www.linuxprinting.org/direct-doc.html>).
- You can view the PPD in your browser through this link: http://www.linuxprinting.org/ppd-o-matic.cgi?driver=ljet4&printer=HP-LaserJet_4_Plus&show=1
- You can also (most importantly) generate and download the PPD: http://www.linuxprinting.org/ppd-o-matic.cgi?driver=ljet4&printer=HP-LaserJet_4_Plus&show=0
- The PPD contains all the information needed to use our model and the driver; this is, once installed, working transparently for the user. Later you'll only need to choose resolution, paper size etc. from the web-based menu, or from the print dialog GUI, or from the commandline.
- Should you have ended up on the driver's page (http://www.linuxprinting.org/show_driver.cgi?driver=ljet4), you can choose to use the "PPD-O-Matic" online PPD generator program.
- Select the exact model and check either "download" or "display PPD file" and click on "Generate PPD file".
- If you save the PPD file from the browser view, please don't use "cut'n'past" (since it could possibly damage line endings and tabs, which makes the PPD likely to fail its duty), but use "Save as..." in your browser's menu. (Best is to use the "download" option from the web page directly).
- Another very interesting part on each driver page is the *Show execution details* button. If you select your printer model and click that button, you will get displayed a complete Ghostscript command line, enumerating all options available for that driver/printermodel combo. This is a great way to "Learn Ghostscript By Doing". It is also an excellent "cheat sheet" for all experienced users who need to re-construct a good command line for that damn printing script, but can't remember the exact syntax. ;-)
- Some time during your visit to Linuxprinting.org, save the PPD to a suitable place on your harddisk, say `/path/to/my-printer.ppd` (if you prefer to install your printers with the help of the CUPS web interface, save the PPD to the `/usr/share/cups/model/` path and re-start cupsd).
- Then install the printer with a suitable commandline, e.g.:

```
lpadmin -p laserjet4plus -v parallel:/dev/lp0 -E -P path/to/my-printer.ppd
```

- Note again this: for all the new-style "Foomatic-PPDs" from Linuxprinting.org, you also need a special "CUPS filter" named "foomatic-rip". Get the latest version of "foomatic-rip" from: <http://www.linuxprinting.org/foomatic2.9/download.cgi?filename=foomatic-rip&show=0>
- The foomatic-rip Perlscript itself also makes some interesting reading (<http://www.linuxprinting.org/foomatic2.9/download.cgi?filename=foomatic-rip&show=1>), because it is very well documented by Till's inline comments (even non-Perl hackers will learn quite a bit about printing by reading it... ;-)
- Save foomatic-rip either directly in `/usr/lib/cups/filter/foomatic-rip` or somewhere in your `$PATH` (and don't forget to make it world-executable). Again, don't save by "copy'n'paste" but use the appropriate link, or the "Save as..." menu item in your browser.
- If you save foomatic-rip in your `$PATH`, create a symlink: `cd /usr/lib/cups/filter/ ; ln -s 'which foomatic-rip'`. For CUPS to discover this new available filter at startup, you need to re-start cupsd.

Once you print to a printqueue set up with the Foomatic-PPD, CUPS will insert the appropriate commands and comments into the resulting PostScript jobfile. foomatic-rip is able to read and act upon these. foomatic-rip uses some specially encoded Foomatic comments, embedded in the jobfile. These in turn are used to construct (transparently for you, the user) the complicated ghostscript command line telling for the printer driver how exactly the resulting raster data should look like and which printer commands to embed into the data stream.

You need:

- A "foomatic+something" PPD – but it is not enough to print with CUPS (it is only *one* important component)
- The "foomatic-rip" filter script (Perl) in `/usr/lib/cups/filters/`
- Perl to make foomatic-rip run
- Ghostscript (because it is doing the main work, controlled by the PPD/foomatic-rip combo) to produce the raster data fit for your printermodel's consumption
- Ghostscript *must* (depending on the driver/model) contain support for a certain "device", representing the selected "driver" for your model (as shown by "gs -h")
- foomatic-rip needs a new version of PPDs (PPD versions produced for cupsonomatic don't work with foomatic-rip).

19.14. Page Accounting with CUPS

Often there are questions regarding "print quotas" wherein Samba users (that is, Windows clients) should not be able to print beyond a certain amount of pages or data volume per day, week or month. This feature is dependent on the real print subsystem you're using. Samba's part is always to receive the job files from the clients (filtered *or* unfiltered) and hand it over to this printing subsystem.

Of course one could "hack" things with one's own scripts. But then there is CUPS. CUPS supports "quotas" which can be based on sizes of jobs or on the number of pages or both, and are spanning any time period you want.

19.14.1. Setting up Quotas

This is an example command how root would set a print quota in CUPS, assuming an existing printer named "quotaprinter":

```
lpadmin -p quotaprinter -o job-quota-period=604800 -o job-k-limit=1024 -o job-page-
```

This would limit every single user to print 100 pages or 1024 KB of data (whichever comes first) within the last 604,800 seconds (= 1 week).

19.14.2. Correct and incorrect Accounting

For CUPS to count correctly, the printfile needs to pass the CUPS "pstops" filter, otherwise it uses a "dummy" count of "1". Some printfiles don't pass it (eg: image files) but then those are mostly 1 page jobs anyway. This also means that proprietary drivers for the target printer running on the client computers and CUPS/Samba, which then spool these files as "raw" (i.e. leaving them untouched, not filtering them), will be counted as "1-pagers" too!

You need to send PostScript from the clients (i.e. run a PostScript driver there) to have the chance to get accounting done. If the printer is a non-PostScript model, you need to let CUPS do the job to convert the file to a print-ready format for the target printer. This will be working for currently about 1,000 different printer models, see http://www.linuxprinting.org/printer_list.cgi.

19.14.3. Adobe and CUPS PostScript Drivers for Windows Clients

Before CUPS-1.1.16 your only option was to use the Adobe PostScript Driver on the Windows clients. The output of this driver was not always passed through the "pstops" filter on the CUPS/Samba side, and therefore was not counted correctly (the reason is that it often, depending on the "PPD" being used, wrote a "PJM"-header in front of the real PostScript which caused CUPS to skip pstops and go directly to the "pstoraster" stage).

From CUPS-1.1.16 onward you can use the "CUPS PostScript Driver for Windows NT/2K/XP clients" (which is tagged in the download area of <http://www.cups.org/> as the "cups-samba-1.1.16.tar.gz" package). It does *not* work for Win9x/ME clients. But it guarantees:

- to not write an PJL-header
- to still read and support all PJL-options named in the driver PPD with its own means
- that the file will pass through the "pstops" filter on the CUPS/Samba server
- to page-count correctly the printfile

You can read more about the setup of this combination in the manpage for "cup-saddsmb" (which is only present with CUPS installed, and only current from CUPS 1.1.16).

19.14.4. The page_log File Syntax

These are the items CUPS logs in the "page_log" for every single *page* of a job:

- Printer name
- User name
- Job ID

- Time of printing
- the page number
- the number of copies
- a billing information string (optional)
- the host which sent the job (included since version 1.1.19)

Here is an extract of my CUPS server's page_log file to illustrate the format and included items:

```
infotec_IS2027 kurt 401 [22/Apr/2003:10:28:43 +0100] 1 3 #marketing 10.160.50.13
infotec_IS2027 kurt 401 [22/Apr/2003:10:28:43 +0100] 2 3 #marketing 10.160.50.13
infotec_IS2027 kurt 401 [22/Apr/2003:10:28:43 +0100] 3 3 #marketing 10.160.50.13
infotec_IS2027 kurt 401 [22/Apr/2003:10:28:43 +0100] 4 3 #marketing 10.160.50.13
DigiMaster9110 boss 402 [22/Apr/2003:10:33:22 +0100] 1 440 finance-dep 10.160.51.33
```

This was job ID "401", printed on "infotec_IS2027" by user "kurt", a 64-page job printed in 3 copies and billed to "#marketing", sent from IP address 10.160.50.13. The next job had ID "402", was sent by user "boss" from IP address 10.160.51.33, printed from one page 440 copies and is set to be billed to "finance-dep".

19.14.5. Possible Shortcomings

What flaws or shortcomings are there with this quota system?

- the ones named above (wrongly logged job in case of printer hardware failure, etc.)
- in reality, CUPS counts the job pages that are being processed in *software* (that is, going through the "RIP") rather than the physical sheets successfully leaving the printing device. Thus if there is a jam while printing the 5th sheet out of 1000 and the job is aborted by the printer, the "page count" will still show the figure of 1000 for that job
- all quotas are the same for all users (no flexibility to give the boss a higher quota than the clerk) no support for groups
- no means to read out the current balance or the "used-up" number of current quota
- a user having used up 99 sheets of 100 quota will still be able to send and print a 1,000 sheet job
- a user being denied a job because of a filled-up quota doesn't get a meaningful error message from CUPS other than "client-error-not-possible".

19.14.6. Future Developments

This is the best system currently available, and there are huge improvements under development for CUPS 1.2:

- page counting will go into the "backends" (these talk directly to the printer and will increase the count in sync with the actual printing process: thus a jam at the 5th sheet will lead to a stop in the counting)
- quotas will be handled more flexibly
- probably there will be support for users to inquire their "accounts" in advance
- probably there will be support for some other tools around this topic

19.14.7. Other Accounting Tools

PrintAnalyzer, pyKota, printbill, LogReport.

19.15. Additional Material

A printer queue with *no* PPD associated to it is a "raw" printer and all files will go directly there as received by the spooler. The exceptions are file types "application/octet-stream" which need "passthrough feature" enabled. "Raw" queues don't do any filtering at all, they hand the file directly to the CUPS backend. This backend is responsible for the sending of the data to the device (as in the "device URI" notation: `lpd://`, `socket://`, `smb://`, `ipp://`, `http://`, `parallel://`, `serial://`, `usb://` etc.)

"cupsomatic"/Foomatic are *not* native CUPS drivers and they don't ship with CUPS. They are a Third Party add-on, developed at Linuxprinting.org. As such, they are a brilliant hack to make all models (driven by Ghostscript drivers/filters in traditional spoolers) also work via CUPS, with the same (good or bad!) quality as in these other spoolers. "cupsomatic" is only a vehicle to execute a ghostscript commandline at that stage in the CUPS filtering chain, where "normally" the native CUPS "pstoraster" filter would kick in. cupsomatic by-passes pstoraster, "kidnaps" the printfile from CUPS away and re-directs it to go through Ghostscript. CUPS accepts this, because the associated CUPS-O-Matic-/Foomatic-PPD specifies:

```
*cupsFilter: "application/vnd.cups-postscript 0 cupsomatic"
```

This line persuades CUPS to hand the file to cupsomatic, once it has successfully converted it to the MIME type "application/vnd.cups-postscript". This conversion will not happen for Jobs arriving from Windows which are auto-typed "application/octet-stream", with the according changes in `/etc/cups/mime.types` in place.

CUPS is widely configurable and flexible, even regarding its filtering mechanism. Another workaround in some situations would be to have in `/etc/cups/mime.types` entries as follows:

```
application/postscript          application/vnd.cups-raw 0 -
application/vnd.cups-postscript  application/vnd.cups-raw 0 -
```

This would prevent all Postscript files from being filtered (rather, they will through the virtual *nullfilter* denoted with "-"). This could only be useful for PS printers. If you want to print PS code on non-PS printers (provided they support ASCII text printing) an entry as follows could be useful:

```
/*/*          application/vnd.cups-raw 0 -
```

and would effectively send *all* files to the backend without further processing. Lastly, you could have the following entry:

```
application/vnd.cups-postscript application/vnd.cups-raw 0 my_PJL_stripping_fi
```

You will need to write a *my-PJL-stripping-filter* (could be a shellsript) that parses the PostScript and removes the unwanted PJL. This would need to conform to CUPS filter design (mainly, receive and pass the parameters printername, job-id, username, jobtitle, copies, print options and possibly the filename). It would be installed as world executable into `/usr/lib/cups/filters/` and will be called by CUPS if it encounters a MIME type "application/vnd.cups-postscript".

CUPS can handle `-o job-hold-until=indefinite`. This keeps the job in the queue "on hold". It will only be printed upon manual release by the printer operator. This is a requirement in many "central reproduction departments", where a few operators manage the jobs of hundreds of users on some big machine, where no user is allowed to have direct access (such as when the operators often need to load the proper paper type before running the 10,000 page job requested by marketing for the mailing, etc.).

19.16. Auto-Deletion or Preservation of CUPS Spool Files

Samba print files pass through two "spool" directories. One is the incoming directory managed by Samba, (set in the `path = /var/spool/samba` directive in the `[printers]` section of `smb.conf`). The other is the spool directory of your UNIX print subsystem. For CUPS it is normally `/var/spool/cups/`, as set by the `cupsd.conf` directive `RequestRoot /var/spool/cups`.

19.16.1. CUPS Configuration Settings explained

Some important parameter settings in the CUPS configuration file `cupsd.conf` are:

PreserveJobHistory Yes This keeps some details of jobs in cupsd's mind (well it keeps the "c12345", "c12346" etc. files in the CUPS spool directory, which do a similar job as the old-fashioned BSD-LPD control files). This is set to "Yes" as a default.

PreserveJobFiles Yes This keeps the job files themselves in cupsd's mind (well it keeps the "d12345", "d12346" etc. files in the CUPS spool directory...). This is set to "No" as the CUPS default.

"MaxJobs 500" This directive controls the maximum number of jobs that are kept in memory. Once the number of jobs reaches the limit, the oldest completed job is automatically purged from the system to make room for the new one. If all of the known jobs are still pending or active then the new job will be rejected. Setting the maximum to 0 disables this functionality. The default setting is 0.

(There are also additional settings for "MaxJobsPerUser" and "MaxJobsPerPrinter"...)

19.16.2. Pre-conditions

For everything to work as announced, you need to have three things:

- a Samba-smbd which is compiled against "libcups" (Check on Linux by running "ldd 'which smbd'")
- a Samba-smb.conf setting of "printing = cups"
- another Samba-smb.conf setting of "printcap = cups"

NOTE

In this case all other manually set printing-related commands (like "print command", "lpq command", "lprm command", "lppause command" or "lppresume command") are ignored and they should normally have no influence what-so-ever on your printing.

19.16.3. Manual Configuration

If you want to do things manually, replace the "printing = cups" by "printing = bsd". Then your manually set commands may work (haven't tested this), and a "print command = lp -d %P %s; rm %s" may do what you need.

19.17. When not to use Samba to print to CUPS

[TO BE DONE]

19.18. In Case of Trouble.....

If you have more problems, post the output of these commands to the CUPS or Samba mailing lists (choose the one which seems more relevant to your problem):

```
grep -v ^# /etc/cups/cupsd.conf | grep -v ^$  
grep -v ^# /etc/samba/smb.conf | grep -v ^$ | grep -v "^.;"
```

(adapt paths as needed). These commands leave out the empty lines and lines with comments, providing the "naked settings" in a compact way. Don't forget to name the CUPS and Samba versions you are using! This saves bandwidth and makes for easier readability for experts (and you are expecting experts to read them, right? ;-)

19.18.1. Where to find Documentation

[TO BE DONE]

19.18.2. How to ask for Help

[TO BE DONE]

19.18.3. Where to find Help

[TO BE DONE]

19.19. Appendix

19.19.1. Printing from CUPS to Windows attached Printers

From time to time the question arises, how you can print *to* a Windows attached printer *from* Samba. Normally the local connection "Windows host <-> printer" would be done by USB or parallel cable, but this doesn't matter to Samba. From here only an SMB connection needs to be opened to the Windows host. Of course, this printer must be "shared" first. As you have learned by now, CUPS uses *backends* to talk to printers and other servers. To talk to Windows shared printers you need to use the *smb* (surprise, surprise!) backend. Check if this is in the CUPS backend directory. This resides usually in `/usr/lib/cups/backend/`. You need to find a "smb" file there. It should be a symlink to `smbspool` which file must exist and be executable:

```
# ls -l /usr/lib/cups/backend/
total 253
drwxr-xr-x  3 root  root           720 Apr 30 19:04 .
drwxr-xr-x  6 root  root           125 Dec 19 17:13 ..
-rwxr-xr-x  1 root  root        10692 Feb 16 21:29 canon
-rwxr-xr-x  1 root  root        10692 Feb 16 21:29 epson
lrwxrwxrwx  1 root  root           3 Apr 17 22:50 http -> ipp
-rwxr-xr-x  1 root  root        17316 Apr 17 22:50 ipp
-rwxr-xr-x  1 root  root        15420 Apr 20 17:01 lpd
-rwxr-xr-x  1 root  root         8656 Apr 20 17:01 parallel
-rwxr-xr-x  1 root  root         2162 Mar 31 23:15 pdfdistiller
lrwxrwxrwx  1 root  root           25 Apr 30 19:04 ptal -> /usr/local/sbin/ptal
-rwxr-xr-x  1 root  root         6284 Apr 20 17:01 scsi
lrwxrwxrwx  1 root  root           17 Apr  2 03:11 smb -> /usr/bin/smbspool
-rwxr-xr-x  1 root  root         7912 Apr 20 17:01 socket
-rwxr-xr-x  1 root  root         9012 Apr 20 17:01 usb

# ls -l 'which smbpool'
-rwxr-xr-x  1 root  root        563245 Dec 28 14:49 /usr/bin/smbpool
```

If this symlink doesn't exist, create it:

```
# ln -s 'which smbpool' /usr/lib/cups/backend/smb
```

`smbspool` has been written by Mike Sweet from the CUPS folks. It is included and ships with Samba. It may also be used with print subsystems other than CUPS, to spool jobs to Windows printer shares. To set up printer "winprinter" on CUPS, you need to have a "driver" for it. Essentially this means to convert the print data on the CUPS/Samba host to a format that the printer can digest (the Windows host is unable to convert any files you may send). This also means you should be able to print to the printer if it were hooked directly at your Samba/CUPS host. For troubleshooting purposes, this is what you should do, to determine if that part of the process chain is in order. Then proceed to fix the network connection/authentication

to the Windows host, etc.

To install a printer with the smb backend on CUPS, use this command:

```
# lpadmin -p winprinter -v smb://WINDOWSNETBIOSNAME/printersharename -P /path/to/PPD
```

The *PPD* must be able to direct CUPS to generate the print data for the target model. For PostScript printers just use the PPD that would be used with the Windows NT PostScript driver. But what can you do if the printer is only accessible with a password? Or if the printer's host is part of another workgroup? This is provided for: you can include the required parameters as part of the `smb://` device-URI. Like this:

```
smb://WORKGROUP/WINDOWSNETBIOSNAME/printersharename
smb://username:password@WORKGROUP/WINDOWSNETBIOSNAME/printersharename
smb://username:password@WINDOWSNETBIOSNAME/printersharename
```

Note that the device-URI will be visible in the process list of the Samba server (e.g. when someone uses the `ps -aux` command on Linux), even if the username and passwords are sanitized before they get written into the log files. So this is an inherently insecure option. However it is the only one. Don't use it if you want to protect your passwords. Better share the printer in a way that doesn't require a password! Printing will only work if you have a working netbios name resolution up and running. Note that this is a feature of CUPS and you don't necessarily need to have `smbd` running (but who wants that? :-).

19.19.2. More CUPS filtering Chains

The following diagrams reveal how CUPS handles print jobs.

```
#####
#
# CUPS in and of itself has this (general) filter chain (CAPITAL
# letters are FILE-FORMATS or MIME types, other are filters (this is
# true for pre-1.1.15 of pre-4.3 versions of CUPS and ESP PrintPro):
#
# SOMETHNG-FILEFORMAT
#   |
#   V
#   somethingtops
#   |
#   V
# APPLICATION/POSTSCRIPT
#   |
#   V
#   pstops
#   |
#   V
# APPLICATION/VND.CUPS-POSTSCRIPT
```

```

# |
# V
# pstoraster # as shipped with CUPS, independent from any Ghostscript
# | # installation on the system
# | (= "postscript interpreter")
# V
# APPLICATION/VND.CUPS-RASTER
# |
# V
# rastertosomething (e.g. Gimp-Print filters may be plugged in here)
# | (= "raster driver")
# V
# SOMETHING-DEVICE-SPECIFIC
# |
# V
# backend
#
#
# ESP PrintPro has some enhanced "rastertosomething" filters as compared to
# CUPS, and also a somewhat improved "pstoraster" filter.
#
# NOTE: Gimp-Print and some other 3rd-Party-Filters (like TurboPrint) to
# CUPS and ESP PrintPro plug-in where rastertosomething is noted.
#
#####

#####

#
# This is how "cupsomatic" comes into play:
# =====
#
# SOMETHNG-FILEFORMAT
# |
# V
# somethingtops
# |
# V
# APPLICATION/POSTSCRIPT
# |
# V
# pstops
# |
# V
# APPLICATION/VND.CUPS-POSTSCRIPT -----+
# | V
# V cupsomatic
# pstoraster (constructs complicated
# | (= "postscript interpreter") Ghostscript commandline
# | to let the file be
# V processed by a
# APPLICATION/VND.CUPS-RASTER "-sDEVICE=s.th."

```



```

#         |                                     call...)
#         V                                     |
#         rastertosomething                     V
#         |   (= "raster driver")             +-----+
#         |                                     | Ghostscript at work.... |
#         V                                     |
# SOMETHING-DEVICE-SPECIFIC                     *-----+
#         |                                     |
#         V                                     |
#         backend <-----+
#         |
#         V
#         THE PRINTER
#
#
# Note, that cupsomatic "kidnaps" the printfile after the
# "APPLICATION/VND.CUPS-POSTSCRPT" stage and deviates it gh
# the CUPS-external, systemwide Ghostscript installation, bypassing the
# "pstoraster" filter (therefore also bypassing the CUPS-raster-drivers
# "rastertosomething", and hands the rasterized file directly to the CUPS
# backend...
#
# cupsomatic is not made by the CUPS developers. It is an independent
# contribution to printing development, made by people from
# Linuxprinting.org. (see also http://www.cups.org/cups-help.html)
#
# NOTE: Gimp-Print and some other 3rd-Party-Filters (like TurboPrint) to
#       CUPS and ESP PrintPro plug-in where rastertosomething is noted.
#
#####

#####

#
# And this is how it works for ESP PrintPro from 4.3:
# =====
#
# SOMETHNG-FILEFORMAT
#         |
#         V
#         somethingtops
#         |
#         V
# APPLICATION/POSTSCRIPT
#         |
#         V
#         pstops
#         |
#         V
# APPLICATION/VND.CUPS-POSTSCRIPT
#         |
#         V

```

```

#      gsrip
#      | (= "postscript interpreter")
#      V
# APPLICATION/VND.CUPS-RASTER
#      |
#      V
#      rastertosomething (e.g. Gimp-Print filters may be plugged in here)
#      | (= "raster driver")
#      V
# SOMETHING-DEVICE-SPECIFIC
#      |
#      V
#      backend
#
# NOTE: Gimp-Print and some other 3rd-Party-Filters (like TurboPrint) to
#       CUPS and ESP PrintPro plug-in where rastertosomething is noted.
#
#####

#####

#
# This is how "cupsomatic" would come into play with ESP PrintPro:
# =====
#
#
# SOMETHNG-FILEFORMAT
#      |
#      V
#      somethingtops
#      |
#      V
# APPLICATION/POSTSCRIPT
#      |
#      V
#      pstops
#      |
#      V
# APPLICATION/VND.CUPS-POSTSCRIPT -----+
#      |                                     V
#      V                                     cupsomatic
#      gsrip                                (constructs complicated
#      | (= "postscript interpreter")       Ghostscript commandline
#      |                                     to let the file be
#      V                                     processed by a
# APPLICATION/VND.CUPS-RASTER              "-sDEVICE=s.th."
#      |                                     call...)
#      V                                     |
#      rastertosomething                    V
#      | (= "raster driver")               +-----+
#      |                                     | Ghostscript at work... |
#      V                                     |

```

```

# SOMETHING-DEVICE-SPECIFIC          *-----+
#   |                                 |
#   V                                 |
#   backend <-----+
#   |
#   V
#   THE PRINTER
#
# NOTE: Gimp-Print and some other 3rd-Party-Filters (like TurboPrint) to
#       CUPS and ESP PrintPro plug-in where rastertosomething is noted.
#
#####

#####

#
# And this is how it works for CUPS from 1.1.15:
# =====
#
# SOMETHNG-FILEFORMAT
#   |
#   V
#   somethingtops
#   |
#   V
# APPLICATION/POSTSCRIPT
#   |
#   V
#   pstops
#   |
#   V
# APPLICATION/VND.CUPS-POSTSCRIPT-----+
#           +-----v-----+
#           | Ghostscript          |
#           | at work...           |
#           | (with                 |
#           | "-sDEVICE=cups")      |
#           |                       |
#           |           (= "postscript interpreter") |
#           |                       |
#           +-----v-----+
#           |
# APPLICATION/VND.CUPS-RASTER >-----+
#   |
#   V
#   rastertosomething
#   |   (= "raster driver")
#   V
# SOMETHING-DEVICE-SPECIFIC
#   |
#   V
#   backend

```

```

#
#
# NOTE: since version 1.1.15 CUPS "outsourced" the pstoraster process to
#       Ghostscript. GNU Ghostscript needs to be patched to handle the
#       CUPS requirement; ESP Ghostscript has this builtin. In any case,
#       "gs -h" needs to show up a "cups" device. pstoraster is now a
#       calling an appropriate "gs -sDEVICE=cups..." commandline to do
#       the job. It will output "application/vnd.cup-raster", which will
#       be finally processed by a CUPS raster driver "rastertosomething"
#       Note the difference to "cupsomatic", which will not output
#       CUPS-raster, but a final version of the printfile, ready to be
#       sent to the printer. cupsomatic also doesn't use the "cups"
#       devicemode in Ghostscript, but one of the classical devicemodes....
#
# NOTE: Gimp-Print and some other 3rd-Party-Filters (like TurboPrint) to
#       CUPS and ESP PrintPro plug-in where rastertosomething is noted.
#
#####

#####

#
# And this is how it works for CUPS from 1.1.15, with cupsomatic included:
# =====
#
# SOMETHNG-FILEFORMAT
#   |
#   V
#   somethingtops
#   |
#   V
# APPLICATION/POSTSCRIPT
#   |
#   V
#   pstops
#   |
#   V
# APPLICATION/VND.CUPS-POSTSCRIPT-----+
#           +-----v-----+
#           | Ghostscript      . Ghostscript at work.... |
#           | at work...      . (with "-sDEVICE="      |
#           | (with          .           s.th."          |
#           | "-sDEVICE=cups") .                       |
#           | .                                                       |
#           | (CUPS standard) .      (cupsomatic)         |
#           | .                                                       |
#           | (= "postscript interpreter")                |
#           | .                                                       |
#           +-----v-----v-----+
#           | |
# APPLICATION/VND.CUPS-RASTER >-----+ |
#           | |

```

```

#      V |
#      rastertosomething |
#      | (= "raster driver") |
#      V |
# SOMETHING-DEVICE-SPECIFIC >-----+
#      |
#      V
#      backend
#
#
# NOTE: Gimp-Print and some other 3rd-Party-Filters (like TurboPrint) to
#       CUPS and ESP PrintPro plug-in where rastertosomething is noted.
#
#####

```

19.19.3. Trouble Shooting Guidelines to fix typical Samba printing Problems

This is a short description of how to debug printing problems with Samba. This describes how to debug problems with printing from a SMB client to a Samba server, not the other way around.

Win9x client can't install driver For Win9x clients require the printer names to be 8 chars (or "8 plus 3 chars suffix") max; otherwise the driver files won't get transferred when you want to download them from Samba.

testparm Run `testparm`: It will tell you if `smb.conf` parameters are in the wrong section. Many people have had the "printer admin" parameter in the `[printers]` section and experienced problems. "testparm" will tell you if it sees this.

"cupsaddsmb" keeps asking for a root password in a neverending loop Have you `security = user`? Have you used `smbpasswd` to give root a Samba account? You can do 2 things: open another terminal and execute `smbpasswd -a root` to create the account, and continue with entering the password into the first terminal. Or break out of the loop by hitting ENTER twice (without trying to type a password).

"cupsaddsmb" gives "No PPD file for printer..." message (but I swear there is one!)

- Have you enabled printer sharing on CUPS? This means: do you have a `<Location /printers>...</Location>` section in CUPS server's `cupsd.conf` which doesn't deny access to the host you run "cupsaddsmb" from? It *could* be an issue if you use `cupsaddsmb` remotely, or if you use it with a `-h` parameter: `cupsaddsmb -H sambaserver -h cupsserver -v printername`.
- Is your "TempDir" directive in `cupsd.conf` set to a valid value and is it writeable?

I can't connect client to Samba printer. Use `smbstatus` to check which user you are from Samba's point of view. Do you have the privileges to write into the `[print$]` share?

I can't reconnect to Samba under a new account from Win2K/XP Once you are connected as the "wrong" user (for example as "nobody", which often occurs if you have `map to guest = bad user`), Windows Explorer will not accept an attempt to connect again as a different user. There won't be any byte transferred on the wire to Samba, but still you'll see a stupid error mes-

sage which makes you think that Samba has denied access. Use **smbstatus** to check for active connections. Kill the PIDs. You still can't re-connect and get the dreaded **You can't connect with a second account from the same machine** message, as soon as you are trying? And you don't see any single byte arriving at Samba (see logs; use "ethereal") indicating a renewed connection attempt? Shut all Explorer Windows. This makes Windows forget what it has cached in its memory as established connections. Then re-connect as the right user. Best method is to use a DOS terminal window and *first* do **net use z: \\SAMBAHOST\print\$ /user:root**. Check with **smbstatus** that you are connected under a different account. Now open the "Printers" folder (on the Samba server in the *Network Neighbourhood*), right-click the printer in question and select *Connect...*

Avoid being connected to the Samba server as the "wrong" user You see per **smbstatus** that you are connected as user "nobody"; while you wanted to be "root" or "printeradmin"? This is probably due to map to guest = bad user, which silently connects you under the guest account, when you gave (maybe by accident) an incorrect username. Remove map to guest, if you want to prevent this.

Upgrading to CUPS drivers from Adobe drivers on NT/2K/XP clients gives problems

First delete all "old" Adobe-using printers. Then delete all "old" Adobe drivers. (On Win2K/XP, right-click in background of "Printers" folder, select "Server Properties...", select tab "Drivers" and delete here).

I can't use "cupsaddsmb" on a Samba server which is a PDC Do you use the "naked" root user name? Try to do it this way: `cupsaddsmb -U DOMAINNAME\root -v printername` (note the two backslashes: the first one is required to "escape" the second one).

I deleted a printer on Win2K; but I still see its driver Deleting a printer on the client won't delete the driver too (to verify, right-click on the white background of the "Printers" folder, select "Server Properties" and click on the "Drivers" tab). These same old drivers will be re-used when you try to install a printer with the same name. If you want to update to a new driver, delete the old ones first. Deletion is only possible if no other printer uses the same driver.

Win2K/XP "Local Security Policies" *Local Security Policies* may not allow the installation of unsigned drivers. "Local Security Policies" may not allow the installation of printer drivers at all.

WinXP clients: "Administrator can not install printers for all local users" Windows XP handles SMB printers on a "per-user" basis. This means every user needs to install the printer himself. To have a printer available for everybody, you might want to use the built-in IPP client capabilities of WinXP. Add a printer with the print path of `http://cupsserver:631/printers/printername`. Still looking into this one: maybe a "logon script" could automatically install printers for all users.

"Print Change Notify" functions on NT++ clients For "print change notify" functions on NT++ clients, these need to run the "Server" service first (re-named to *File & Print Sharing for MS Networks* in XP).

WinXP-SP1 WinXP-SP1 introduced a *Point and Print Restriction Policy* (this restriction doesn't apply to "Administrator" or "Power User" groups of users). In Group Policy Object Editor: go to *User Configuration* -> *Administrative Templates* -> *Control Panel* -> *Printers*. The policy is automatically set to *Enabled* and the *Users can only Point and Print to machines in their Forest*. You probably need to change it to *Disabled* or *Users can only Point and Print to these servers* in order to make driver downloads from Samba possible.

I can't set and save default print options for all users on Win2K/XP How are you doing it? I bet the wrong way (it is not very easy to find out, though). There are 3 different ways to bring you to a dialog that *seems* to set everything. All three dialogs *look* the same. Only one of them *does* what you intend. You need to be Administrator or Print Administrator to do this for all users. Here is how I do in on XP:

A The first "wrong" way:

- 1 Open the *Printers* folder.
- 2 Right-click on the printer (*remotepri nter on cupshost*) and select in context menu *Printing Preferences...*
- 3 Look at this dialog closely and remember what it looks like.

B The second "wrong" way:

- 1 Open the *Printers* folder.
- 2 Right-click on the printer (*remotepri nter on cupshost*) and select in the context menu *Properties*
- 3 Click on the *General* tab
- 4 Click on the button *Printing Preferences...*
- 5 A new dialog opens. Keep this dialog open and go back to the parent dialog.

C The third, the "correct" way: (should you do this from the beginning, just carry out steps 1. and 2. from second "way" above)

- 1 Click on the *Advanced* tab. (Hmmm... if everything is "Grayed Out", then you are not logged in as a user with enough privileges).
- 2 Click on the *Printing Defaults...* button.
- 3 On any of the two new tabs, click on the *Advanced...* button.
- 4 A new dialog opens. Compare this one to the other, identical looking one from "B.5" or A.3".

Do you see any difference? I don't either... However, only the last one, which you arrived at with steps "C.1.-6." will save any settings permanently and be the defaults for new users. If you want all clients to get the same defaults, you need to conduct these steps *as Administrator* (printer admin in `smb.conf`) *before* a client downloads the driver (the clients can later set their own *per-user defaults* by following the procedures A. or B. above).

What are the most common blunders in driver settings on Windows clients? Don't use *Optimize for Speed*: use *Optimize for Portability* instead (Adobe PS Driver) Don't use *Page Independence: No*: always settle with *Page Independence: Yes* (Microsoft PS Driver and CUPS PS Driver for WinNT/2K/XP) If there are problems with fonts: use *Download as Softfont into printer* (Adobe PS Driver). For *TrueType Download Options* choose *Outline*. Use PostScript Level 2, if you are having trouble with a non-PS printer, and if there is a choice.

I can't make cupsaddsmb work with newly installed printer Symptom: the last command of `cupsaddsmb` doesn't complete successfully: `cmd = setdriver printername printername` result was `NT_STATUS_UNSUCCESSFUL` then possibly the printer was not yet "recognized" by Samba. Did it show up in *Network Neighbourhood*? Did it show up in `rpcclient hostname -c 'enumprinters'`? Restart `smbd` (or send a `kill -HUP` to all processes listed by `smbstatus` and try again).

My permissions on /var/spool/samba/ get reset after each reboot Have you by accident set the CUPS spool directory to the same location? (RequestRoot /var/spool/samba/ in `cupsd.conf` or the other way round: /var/spool/cups/ is set as path in the [printers] section). These *must* be different. Set RequestRoot /var/spool/cups/ in `cupsd.conf` and path = /var/spool/samba in the

[printers] section of `smb.conf`. Otherwise `cupsd` will sanitize permissions to its spool directory with each restart, and printing will not work reliably.

My printers work fine: just the printer named "lp" intermittently swallows jobs and spits out cor

It is a very bad idea to name any printer "lp". This is the traditional Unix name for the default printer. CUPS may be set up to do an automatic creation of "Implicit Classes". This means, to group all printers with the same name to a pool of devices, and loadbalancing the jobs across them in a round-robin fashion. Chances are high that someone else has an "lp" named printer too. You may receive his jobs and send your own to his device unwittingly. To have tight control over the printer names, set `BrowseShortNames No`. It will present any printer as "printername@cupshost" then, giving you a better control over what may happen in a large networked environment.

How do I "watch" my Samba server? You can use `tail -f /var/log/samba/log.smbd`

(you may need a different path) to see a live scrolling of all log messages. `smbcontrol smbd debuglevel` tells you which verbosity goes into the logs. `smbcontrol smbd debug 3` sets the verbosity to a quite high level (you can choose from 0 to 10 or 100). This works "on the fly", without the need to restart the `smbd` daemon. Don't use more than 3 initially; or you'll drown in an ocean of messages.

I can't use Samba from my WinXP Home box, while access from WinXP Prof works flawlessly

You have our condolences! WinXP home has been completely neutered by Microsoft as compared to WinXP Prof: you can not log into a WinNT domain. It cannot join a Win NT domain as a member server. While it is possible to access domain resources, users don't have "single sign-on". They need to supply username and password each time they connect to a resource. Logon scripts and roaming profiles are not supported. It can serve file and print shares; but only in "share-mode security" level. It can not use "user-mode security" (what Windows 95/98/ME still can do).

Where do I find the Adobe PostScript driver files I need for "cupsaddsmb"? Use

`smbclient` to connect to any Windows box with a shared PostScript printer: `smbclient //windowsbox/print/$ -U guest`. You can navigate to the `W32X86/2` subdir to `mget ADOBE*` and other files or to `WIN40/0` to do the same. – Another option is to download the `*.exe` packaged files from the Adobe website.

19.19.4. An Overview of the CUPS Printing Processes

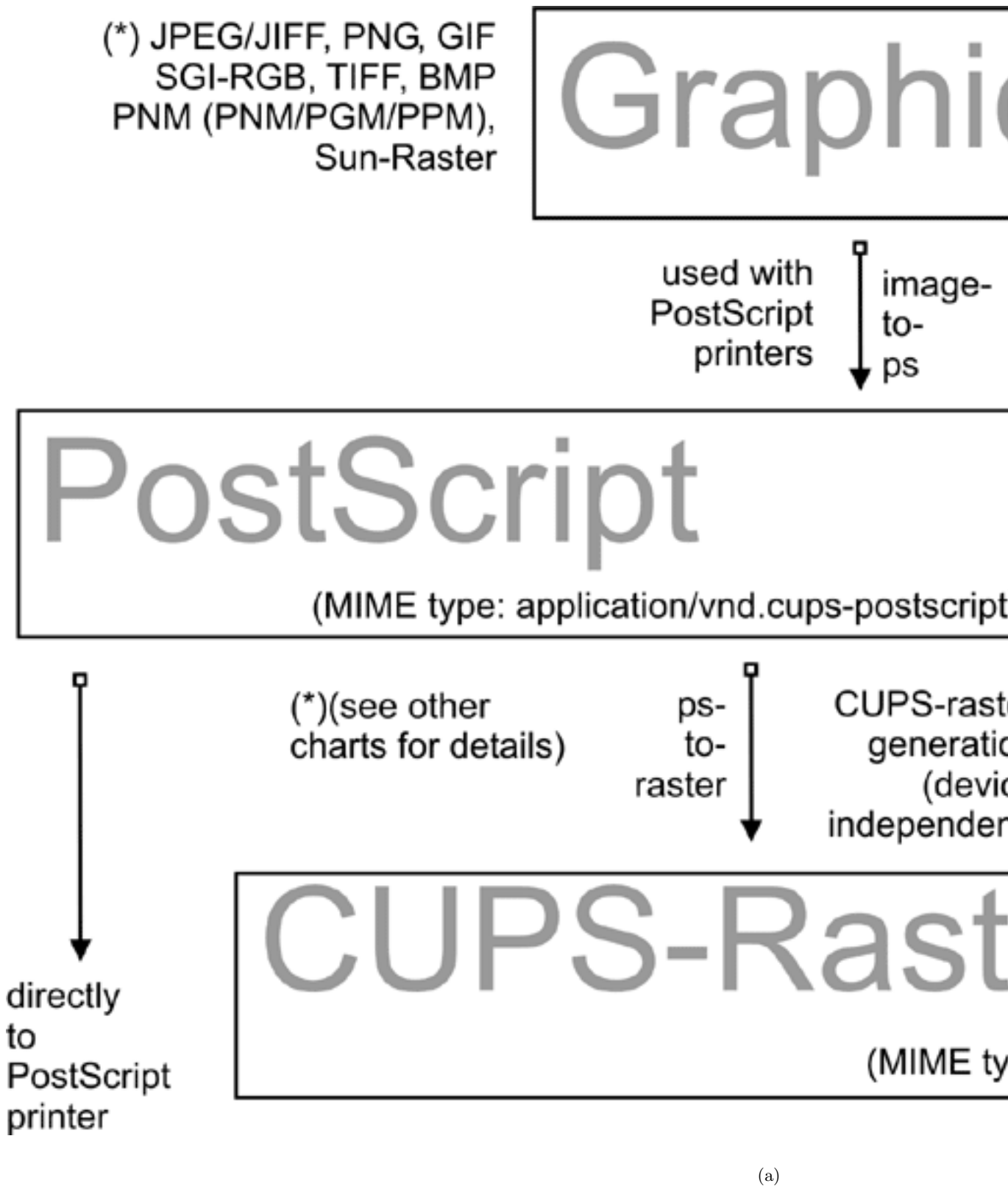

Figure 19.8: Image format to CUPS-raster format conversion

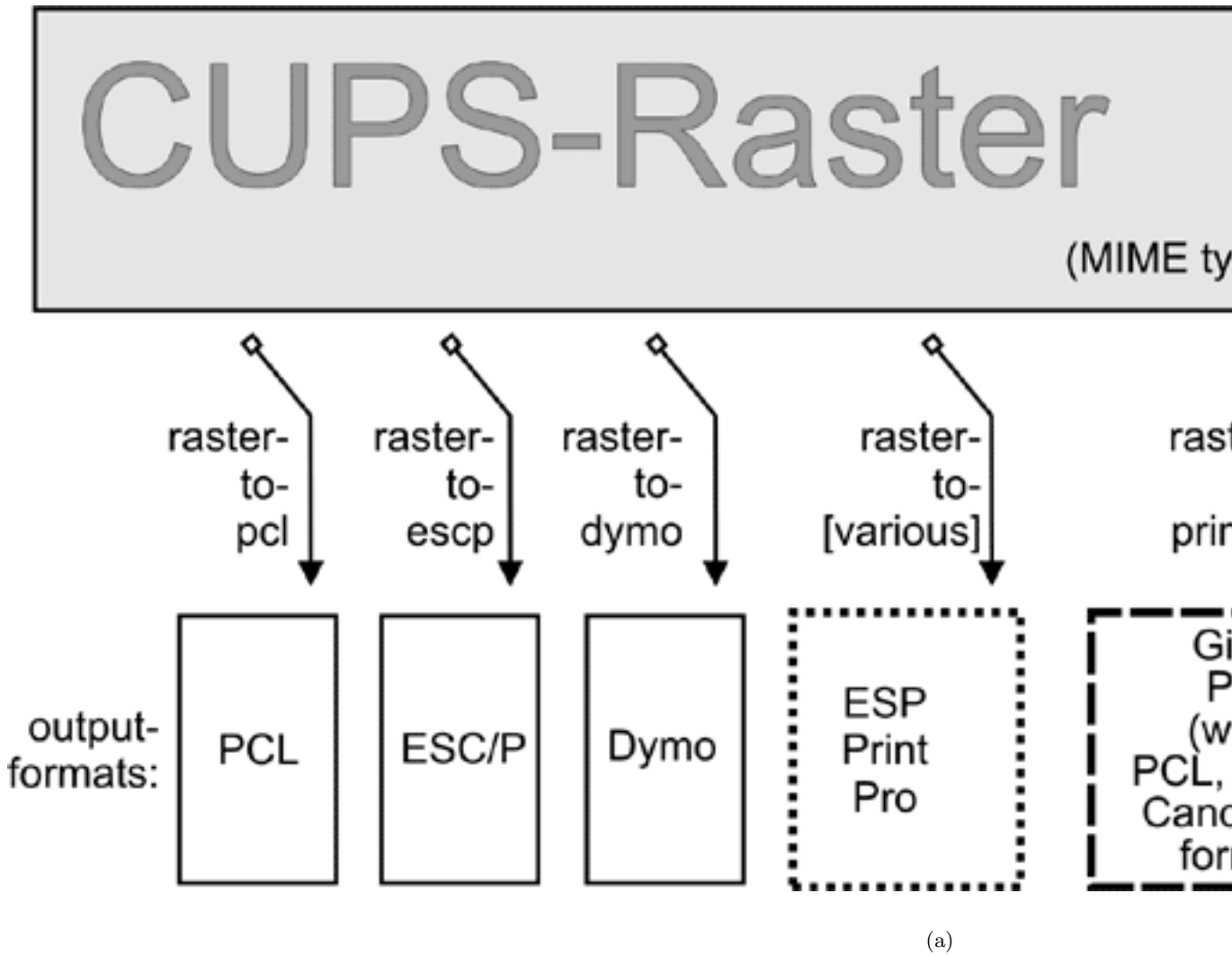
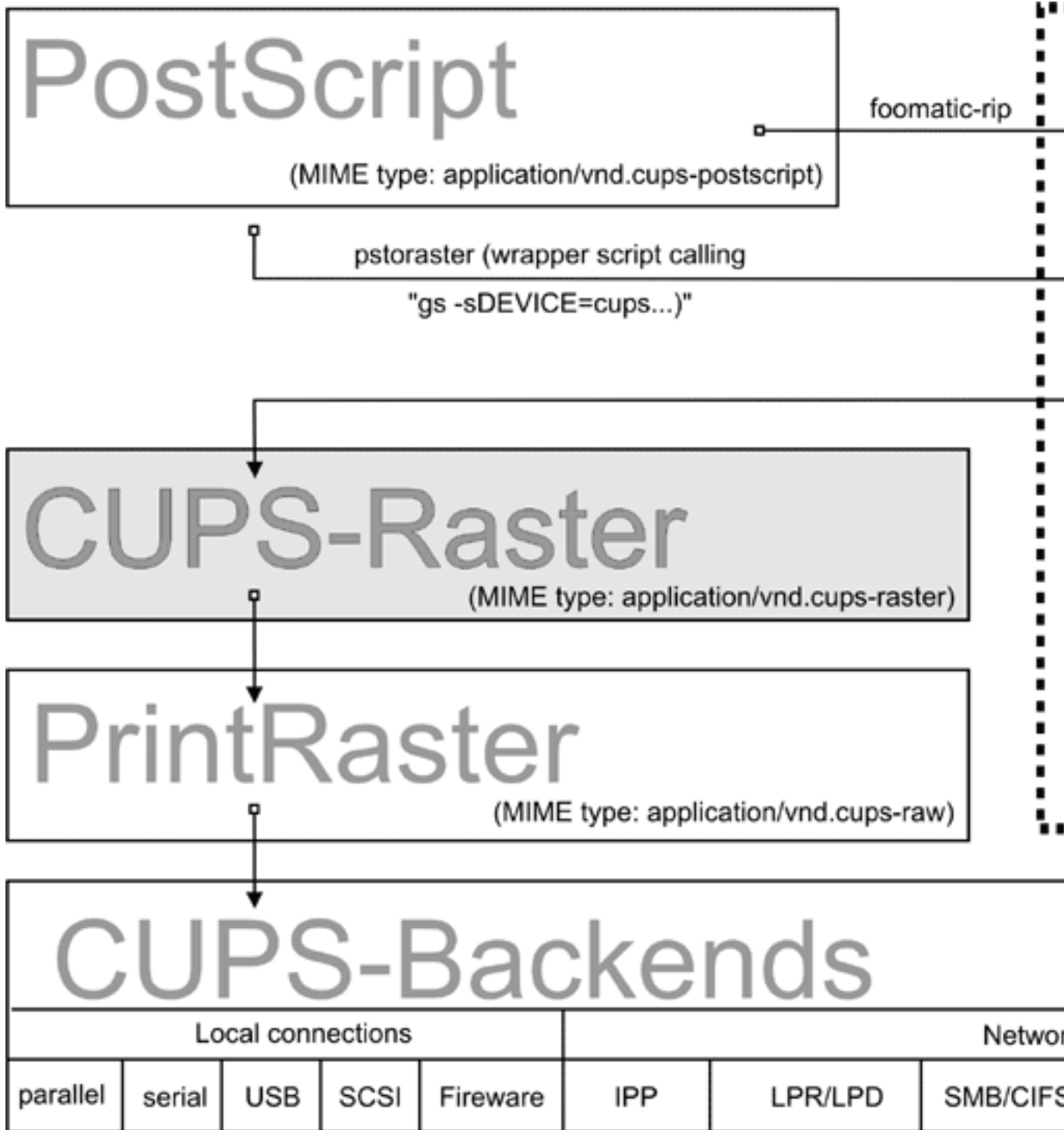
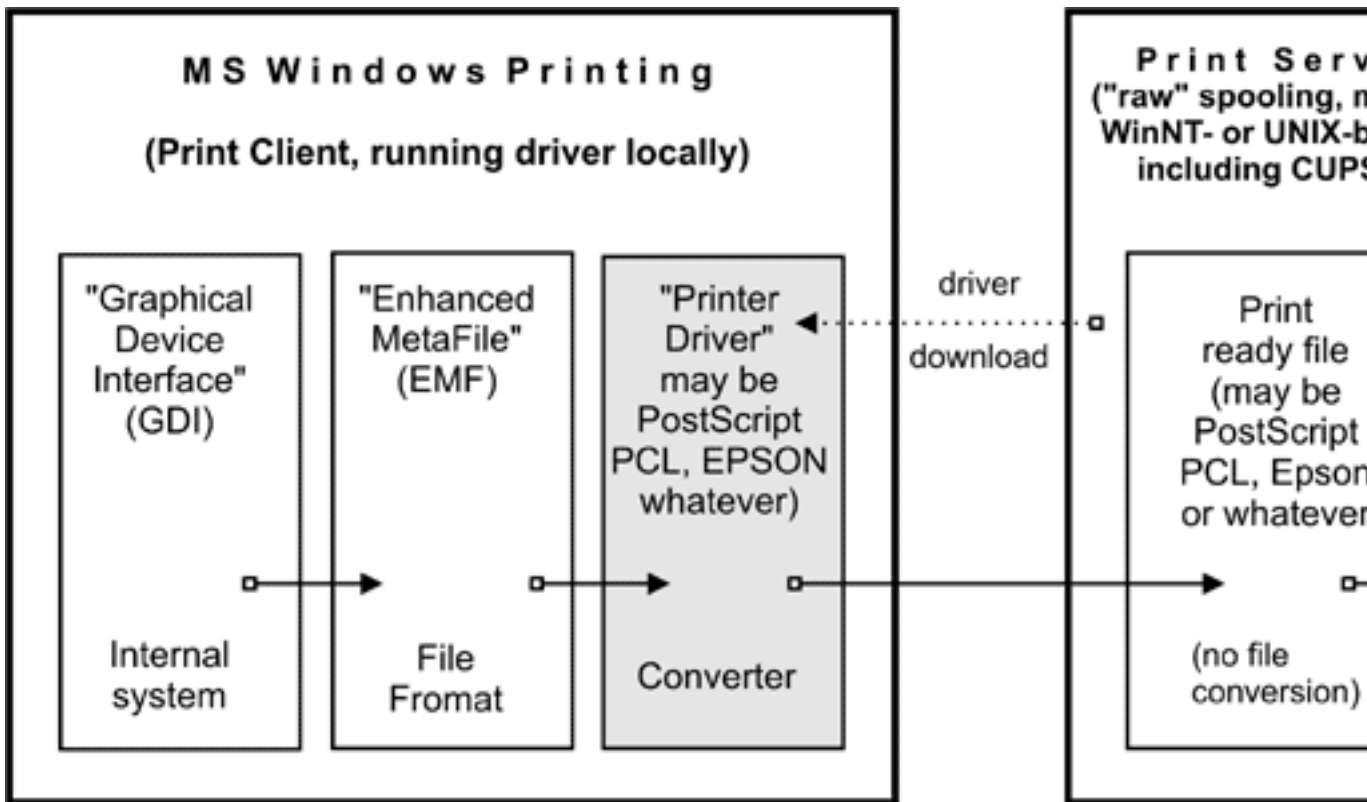

Figure 19.9: Raster to Printer Specific formats



(a)

Figure 19.10: cupsomatic/foomatic processing versus Native CUPS



(a)

Figure 19.11: Print Driver execution on the Client

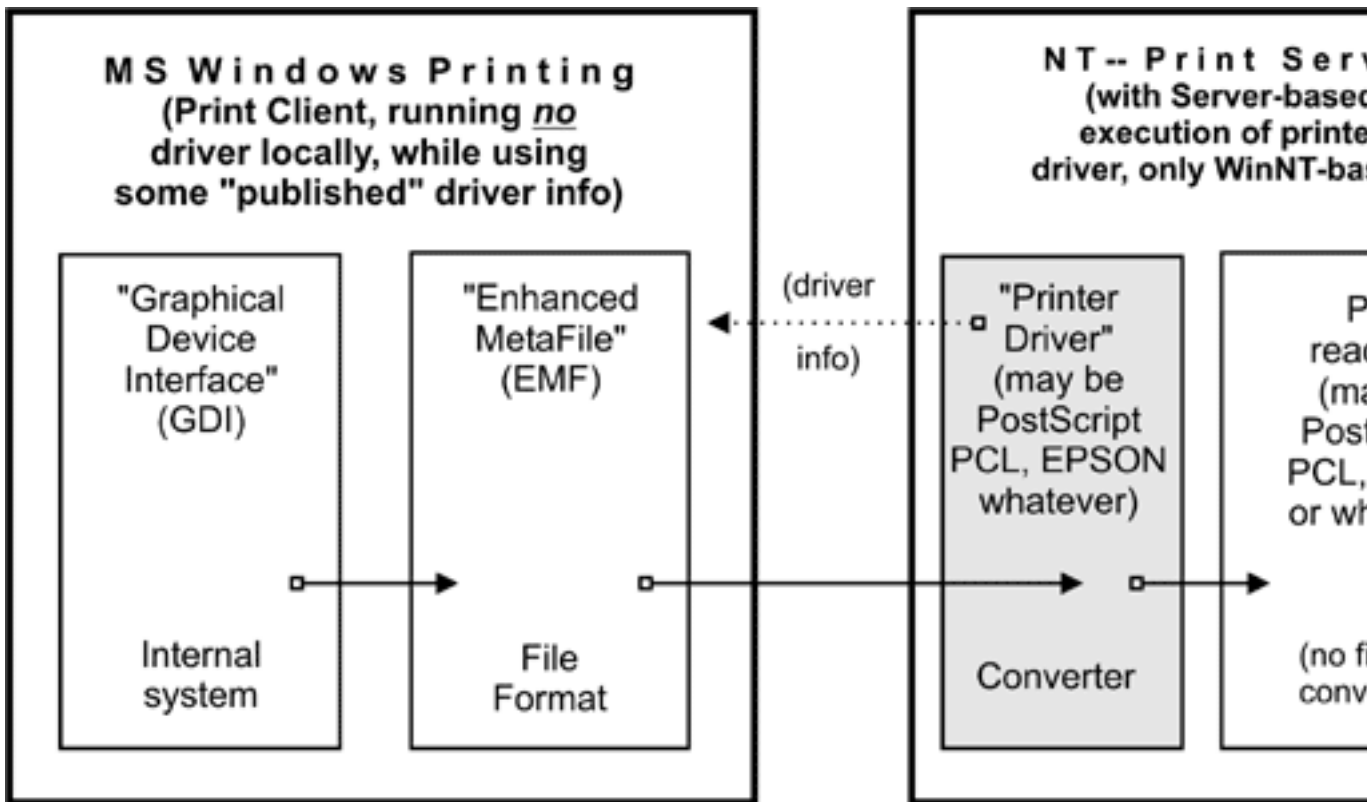

(a)

Figure 19.12: Print Driver execution on the Server

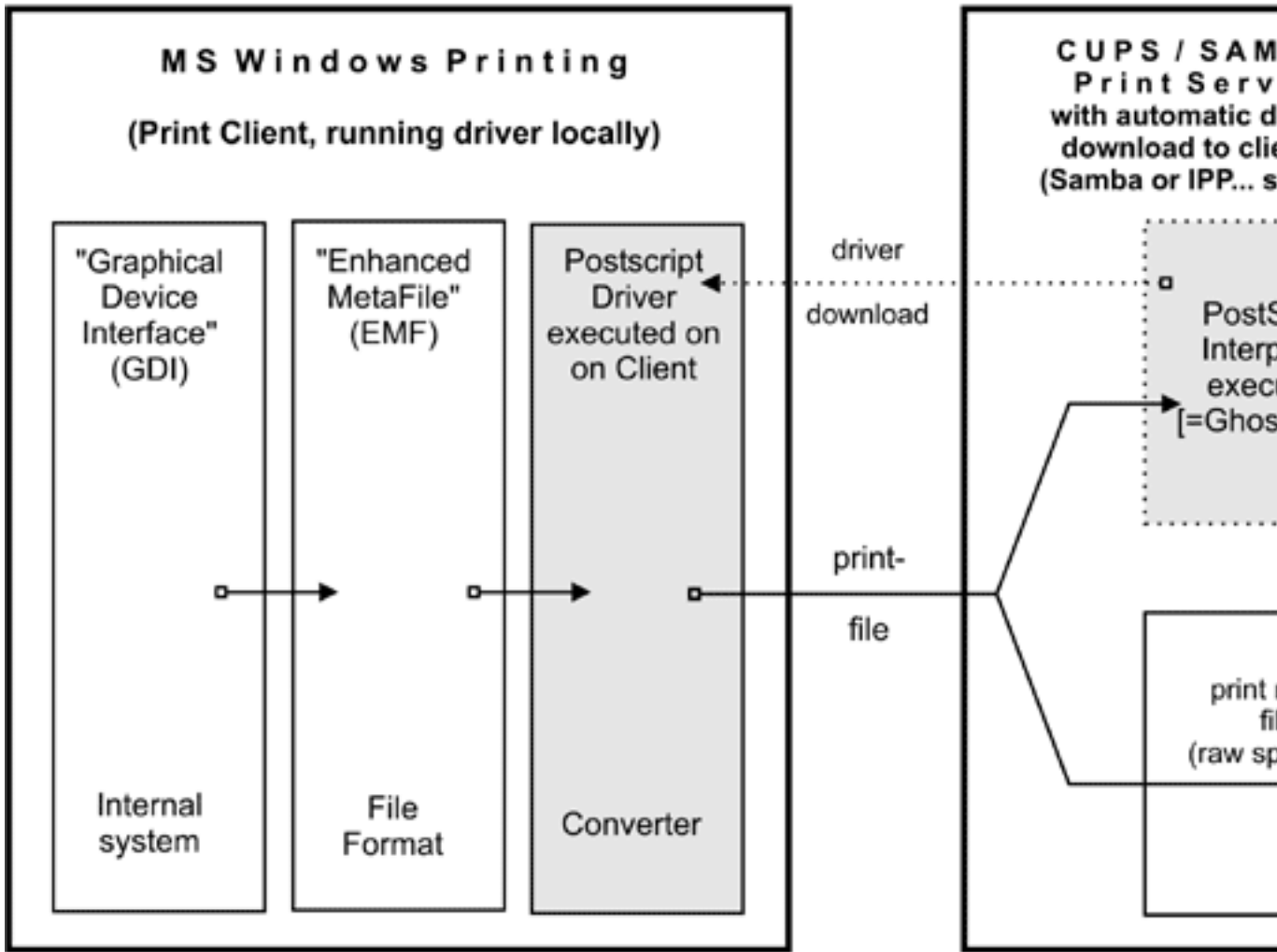

(a)

Figure 19.13: Printing via CUPS/samba server

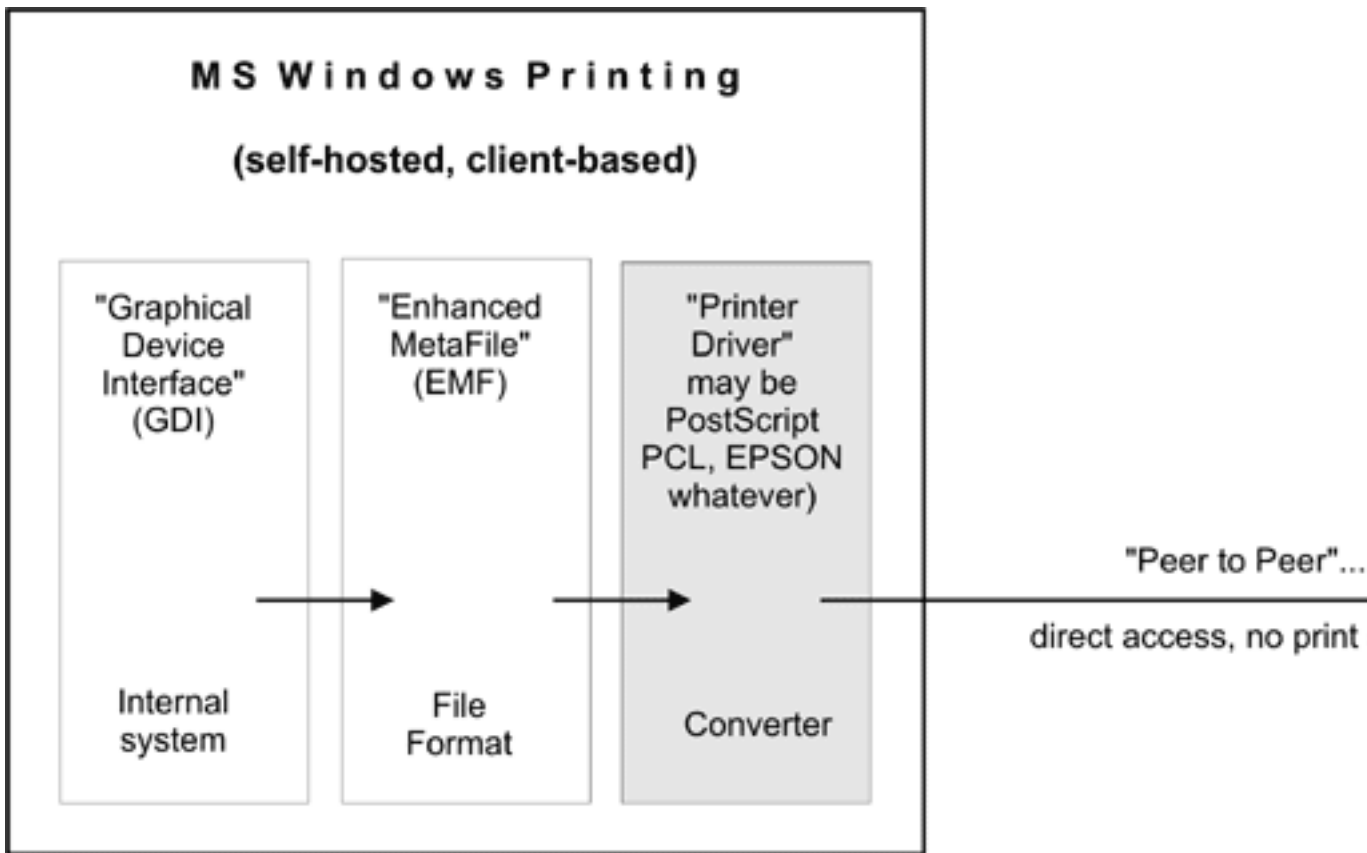

(a)

Figure 19.14: cupsaddsmb flowchart

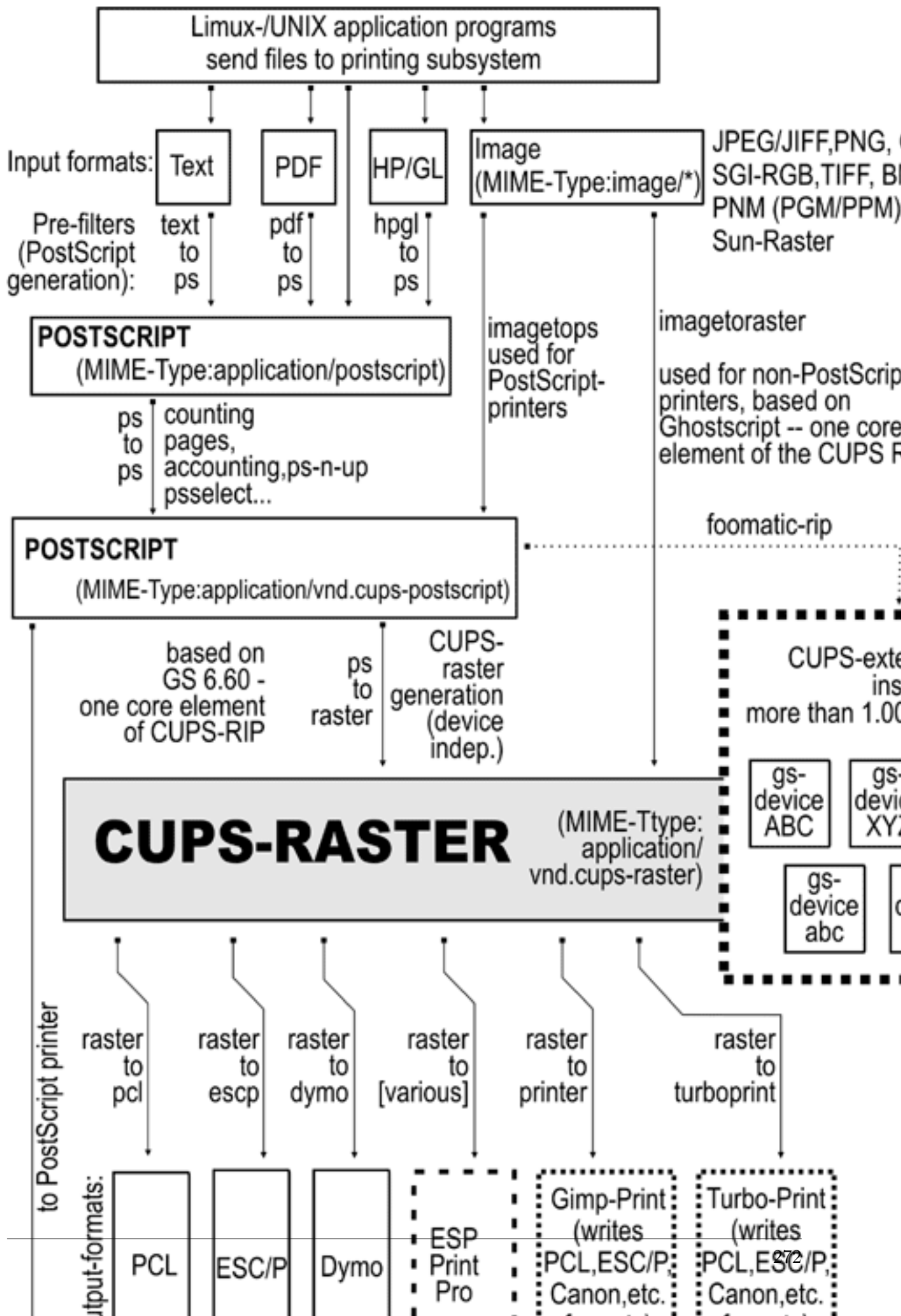

20. Stackable VFS modules

20.1. Features and Benefits

Since Samba-3, there is support for stackable VFS(Virtual File System) modules. Samba passes each request to access the unix file system thru the loaded VFS modules. This chapter covers all the modules that come with the samba source and references to some external modules.

20.2. Discussion

If not supplied with your platform distribution binary Samba package you may have problems to compile these modules, as shared libraries are compiled and linked in different ways on different systems. They currently have been tested against GNU/Linux and IRIX.

To use the VFS modules, create a share similar to the one below. The important parameter is the `vfs object` parameter which must point to the exact pathname of the shared library objects. For example, to log all access to files and use a recycle bin:

```
[audit]
comment = Audited /data directory
path = /data
vfs object = /path/to/audit.so /path/to/recycle.so
writeable = yes
browseable = yes
```

The modules are used in the order they are specified.

Further documentation on writing VFS modules for Samba can be found in the Samba Developers Guide.

20.3. Included modules

20.3.1. audit

A simple module to audit file access to the syslog facility. The following operations are logged:

- share
- connect/disconnect
- directory opens/create/remove
- file open/close/rename/unlink/chmod

20.3.2. extd_audit

This module is identical with the `audit` module above except that it sends audit logs to both syslog as well as the `smbd log file/s`. The `loglevel` for this module is set in the `smb.conf` file.

The logging information that will be written to the `smbd` log file is controlled by the `log level` parameter in `smb.conf`. The following information will be recorded:

Table 20.1: Extended Auditing Log Information

Log Level	Log Details - File and Directory Operations
0	Creation / Deletion
1	Create / Delete / Rename / Permission Changes
2	Create / Delete / Rename / Perm Change / Open / Close

20.3.3. `fake_perms`

This module was created to allow Roaming Profile files and directories to be set (on the Samba server under Unix) as read only. This module will if installed on the Profiles share will report to the client that the Profile files and directories are writable. This satisfies the client even though the files will never be overwritten as the client logs out or shuts down.

20.3.4. `recycle`

A recycle-bin like module. When used any unlink call will be intercepted and files moved to the recycle directory instead of being deleted.

Supported options:

`vfs_recycle_bin:repository` FIXME
`vfs_recycle_bin:keeptree` FIXME
`vfs_recycle_bin:versions` FIXME
`vfs_recycle_bin:touch` FIXME
`vfs_recycle_bin:maxsize` FIXME
`vfs_recycle_bin:exclude` FIXME
`vfs_recycle_bin:exclude_dir` FIXME
`vfs_recycle_bin:noverisons` FIXME

20.3.5. `netatalk`

A netatalk module, that will ease co-existence of samba and netatalk file sharing services.

Advantages compared to the old netatalk module:

- it doesn't care about creating of `.AppleDouble` forks, just keeps them in sync
- if a share in `smb.conf` doesn't contain `.AppleDouble` item in `hide` or `veto` list, it will be added automatically

20.4. VFS modules available elsewhere

This section contains a listing of various other VFS modules that have been posted but don't currently reside in the Samba CVS tree for one reason or another (e.g. it is easy for the maintainer to have his or her own CVS tree).

No statements about the stability or functionality of any module should be implied due to its presence here.

20.4.1. DatabaseFS

URL: <http://www.css.tayloru.edu/~elorimer/databasefs/index.php>

By Eric Lorimer.

I have created a VFS module which implements a fairly complete read-only filesystem. It presents information from a database as a filesystem in a modular and generic way to allow different databases to be used (originally designed for organizing MP3s under directories such as "Artists," "Song Keywords," etc... I have since applied it to a student roster database very easily). The directory structure is stored in the database itself and the module makes no assumptions about the database structure beyond the table it requires to run.

Any feedback would be appreciated: comments, suggestions, patches, etc... If nothing else, hopefully it might prove useful for someone else who wishes to create a virtual filesystem.

20.4.2. vscan

URL: <http://www.openantivirus.org/>

samba-vscan is a proof-of-concept module for Samba, which uses the VFS (virtual file system) features of Samba 2.2.x/3.0 alphaX. Of course, Samba has to be compiled with VFS support. samba-vscan supports various virus scanners and is maintained by Rainer Link.

20.5. Common Errors

There must be some gotchas we should record here! Jelmer???

21. Integrated Logon Support using Winbind

21.1. Features and Benefits

Integration of UNIX and Microsoft Windows NT through a unified logon has been considered a "holy grail" in heterogeneous computing environments for a long time. We present *winbind*, a component of the Samba suite of programs as a solution to the unified logon problem. Winbind uses a UNIX implementation of Microsoft RPC calls, Pluggable Authentication Modules, and the Name Service Switch to allow Windows NT domain users to appear and operate as UNIX users on a UNIX machine. This paper describes the winbind system, explaining the functionality it provides, how it is configured, and how it works internally.

21.2. Introduction

It is well known that UNIX and Microsoft Windows NT have different models for representing user and group information and use different technologies for implementing them. This fact has made it difficult to integrate the two systems in a satisfactory manner.

One common solution in use today has been to create identically named user accounts on both the UNIX and Windows systems and use the Samba suite of programs to provide file and print services between the two. This solution is far from perfect however, as adding and deleting users on both sets of machines becomes a chore and two sets of passwords are required both of which can lead to synchronization problems between the UNIX and Windows systems and confusion for users.

We divide the unified logon problem for UNIX machines into three smaller problems:

- Obtaining Windows NT user and group information
- Authenticating Windows NT users
- Password changing for Windows NT users

Ideally, a prospective solution to the unified logon problem would satisfy all the above components without duplication of information on the UNIX machines and without creating additional tasks for the system administrator when maintaining users and groups on either system. The winbind system provides a simple and elegant solution to all three components of the unified logon problem.

21.3. What Winbind Provides

Winbind unifies UNIX and Windows NT account management by allowing a UNIX box to become a full member of a NT domain. Once this is done the UNIX box will see NT users and groups as if they were native UNIX users and groups, allowing the NT domain to be used in much the same manner that NIS+ is used within UNIX-only environments.

The end result is that whenever any program on the UNIX machine asks the operating system to lookup a user or group name, the query will be resolved by

asking the NT domain controller for the specified domain to do the lookup. Because Winbind hooks into the operating system at a low level (via the NSS name resolution modules in the C library) this redirection to the NT domain controller is completely transparent.

Users on the UNIX machine can then use NT user and group names as they would use "native" UNIX names. They can chown files so that they are owned by NT domain users or even login to the UNIX machine and run a UNIX X-Window session as a domain user.

The only obvious indication that Winbind is being used is that user and group names take the form DOMAIN\user and DOMAIN\group. This is necessary as it allows Winbind to determine that redirection to a domain controller is wanted for a particular lookup and which trusted domain is being referenced.

Additionally, Winbind provides an authentication service that hooks into the Pluggable Authentication Modules (PAM) system to provide authentication via a NT domain to any PAM enabled applications. This capability solves the problem of synchronizing passwords between systems since all passwords are stored in a single location (on the domain controller).

21.3.1. Target Uses

Winbind is targeted at organizations that have an existing NT based domain infrastructure into which they wish to put UNIX workstations or servers. Winbind will allow these organizations to deploy UNIX workstations without having to maintain a separate account infrastructure. This greatly simplifies the administrative overhead of deploying UNIX workstations into a NT based organization.

Another interesting way in which we expect Winbind to be used is as a central part of UNIX based appliances. Appliances that provide file and print services to Microsoft based networks will be able to use Winbind to provide seamless integration of the appliance into the domain.

21.4. How Winbind Works

The winbind system is designed around a client/server architecture. A long running **winbindd** daemon listens on a UNIX domain socket waiting for requests to arrive. These requests are generated by the NSS and PAM clients and processed sequentially.

The technologies used to implement winbind are described in detail below.

21.4.1. Microsoft Remote Procedure Calls

Over the last few years, efforts have been underway by various Samba Team members to decode various aspects of the Microsoft Remote Procedure Call (MSRPC) system. This system is used for most network related operations between Windows NT machines including remote management, user authentication and print spooling. Although initially this work was done to aid the implementation of Primary Domain Controller (PDC) functionality in Samba, it has also yielded a body of code which can be used for other purposes.

Winbind uses various MSRPC calls to enumerate domain users and groups and to obtain detailed information about individual users or groups. Other MSRPC calls can be used to authenticate NT domain users and to change user passwords. By directly querying a Windows PDC for user and group information, winbind maps the NT account information onto UNIX user and group names.

21.4.2. Microsoft Active Directory Services

Since late 2001, Samba has gained the ability to interact with Microsoft Windows 2000 using its 'Native Mode' protocols, rather than the NT4 RPC services. Using LDAP and Kerberos, a domain member running winbind can enumerate users and groups in exactly the same way as a Win2k client would, and in so doing provide a much more efficient and effective winbind implementation.

21.4.3. Name Service Switch

The Name Service Switch, or NSS, is a feature that is present in many UNIX operating systems. It allows system information such as hostnames, mail aliases and user information to be resolved from different sources. For example, a standalone UNIX workstation may resolve system information from a series of flat files stored on the local filesystem. A networked workstation may first attempt to resolve system information from local files, and then consult a NIS database for user information or a DNS server for hostname information.

The NSS application programming interface allows winbind to present itself as a source of system information when resolving UNIX usernames and groups. Winbind uses this interface, and information obtained from a Windows NT server using MSRPC calls to provide a new source of account enumeration. Using standard UNIX library calls, one can enumerate the users and groups on a UNIX machine running winbind and see all users and groups in a NT domain plus any trusted domain as though they were local users and groups.

The primary control file for NSS is `/etc/nsswitch.conf`. When a UNIX application makes a request to do a lookup the C library looks in `/etc/nsswitch.conf` for a line which matches the service type being requested, for example the "passwd" service type is used when user or group names are looked up. This config line species which implementations of that service should be tried and in what order. If the passwd config line is:

```
passwd: files example
```

then the C library will first load a module called `/lib/libnss_files.so` followed by the module `/lib/libnss_example.so`. The C library will dynamically load each of these modules in turn and call resolver functions within the modules to try to resolve the request. Once the request is resolved the C library returns the result to the application.

This NSS interface provides a very easy way for Winbind to hook into the operating system. All that needs to be done is to put `libnss_winbind.so` in `/lib/` then add "winbind" into `/etc/nsswitch.conf` at the appropriate place. The C library will then call Winbind to resolve user and group names.

21.4.4. Pluggable Authentication Modules

Pluggable Authentication Modules, also known as PAM, is a system for abstracting authentication and authorization technologies. With a PAM module it is possible to specify different authentication methods for different system applications without having to recompile these applications. PAM is also useful for implementing a particular policy for authorization. For example, a system administrator may only allow console logins from users stored in the local password file but only allow users resolved from a NIS database to log in over the network.

Winbind uses the authentication management and password management PAM interface to integrate Windows NT users into a UNIX system. This allows Windows NT users to log in to a UNIX machine and be authenticated against a suitable Primary Domain Controller. These users can also change their passwords and have this change take effect directly on the Primary Domain Controller.

PAM is configured by providing control files in the directory `/etc/pam.d/` for each of the services that require authentication. When an authentication request is made by an application the PAM code in the C library looks up this control file to determine what modules to load to do the authentication check and in what order. This interface makes adding a new authentication service for Winbind very easy, all that needs to be done is that the `pam_winbind.so` module is copied to `/lib/security/` and the PAM control files for relevant services are updated to allow authentication via winbind. See the PAM documentation for more details.

21.4.5. User and Group ID Allocation

When a user or group is created under Windows NT is it allocated a numerical relative identifier (RID). This is slightly different to UNIX which has a range of numbers that are used to identify users, and the same range in which to identify groups. It is winbind's job to convert RIDs to UNIX id numbers and vice versa. When winbind is configured it is given part of the UNIX user id space and a part of the UNIX group id space in which to store Windows NT users and groups. If a Windows NT user is resolved for the first time, it is allocated the next UNIX id from the range. The same process applies for Windows NT groups. Over time, winbind will have mapped all Windows NT users and groups to UNIX user ids and group ids.

The results of this mapping are stored persistently in an ID mapping database held in a tdb database). This ensures that RIDs are mapped to UNIX IDs in a consistent way.

21.4.6. Result Caching

An active system can generate a lot of user and group name lookups. To reduce the network cost of these lookups winbind uses a caching scheme based on the SAM sequence number supplied by NT domain controllers. User or group information returned by a PDC is cached by winbind along with a sequence number also returned by the PDC. This sequence number is incremented by Windows NT whenever any user or group information is modified. If a cached entry has expired, the sequence number is requested from the PDC and compared against the sequence number of the cached entry. If the sequence numbers do not match, then the cached information is discarded and up to date information is requested directly from the PDC.

21.5. Installation and Configuration

Many thanks to John Trostel jtrostel@snapserver.com for providing the HOWTO for this section.

This HOWTO describes how to get winbind services up and running to control access and authenticate users on your Linux box using the winbind services which come with SAMBA 3.0.

21.5.1. Introduction

This section describes the procedures used to get winbind up and running on a Red-Hat 7.1 system. Winbind is capable of providing access and authentication control

for Windows Domain users through an NT or Win2K PDC for 'regular' services, such as telnet and ftp, as well for SAMBA services.

This HOWTO has been written from a 'RedHat-centric' perspective, so if you are using another distribution, you may have to modify the instructions somewhat to fit the way your distribution works.

- *Why should I do this?*

This allows the SAMBA administrator to rely on the authentication mechanisms on the NT/Win2K PDC for the authentication of domain members. NT/Win2K users no longer need to have separate accounts on the SAMBA server.

- *Who should be reading this document?*

This HOWTO is designed for system administrators. If you are implementing SAMBA on a file server and wish to (fairly easily) integrate existing NT/Win2K users from your PDC onto the SAMBA server, this HOWTO is for you. That said, I am no NT or PAM expert, so you may find a better or easier way to accomplish these tasks.

21.5.2. Requirements

If you have a samba configuration file that you are currently using... *BACK IT UP!* If your system already uses PAM, *back up the /etc/pam.d directory contents!* If you haven't already made a boot disk, *MAKE ONE NOW!*

Messing with the pam configuration files can make it nearly impossible to log in to your machine. That's why you want to be able to boot back into your machine in single user mode and restore your `/etc/pam.d` back to the original state they were in if you get frustrated with the way things are going. ;-)

The latest version of SAMBA (version 3.0 as of this writing), now includes a functioning winbind daemon. Please refer to the [main SAMBA web page](#) or, better yet, your closest SAMBA mirror site for instructions on downloading the source code.

To allow Domain users the ability to access SAMBA shares and files, as well as potentially other services provided by your SAMBA machine, PAM (pluggable authentication modules) must be setup properly on your machine. In order to compile the winbind modules, you should have at least the pam libraries resident on your system. For recent RedHat systems (7.1, for instance), that means `pam-0.74-22`. For best results, it is helpful to also install the development packages in `pam-devel-0.74-22`.

21.5.3. Testing Things Out

Before starting, it is probably best to kill off all the SAMBA related daemons running on your server. Kill off all `smbd`, `nmbd`, and `winbindd` processes that may be running. To use PAM, you will want to make sure that you have the standard PAM package (for RedHat) which supplies the `/etc/pam.d` directory structure, including the pam modules are used by pam-aware services, several pam libraries, and the `/usr/doc` and `/usr/man` entries for pam. Winbind built better in SAMBA if the `pam-devel` package was also installed. This package includes the header files needed to compile pam-aware applications.

21.5.3.1. Configure and compile SAMBA

The configuration and compilation of SAMBA is pretty straightforward. The first three steps may not be necessary depending upon whether or not you have previously built the Samba binaries.

```
root# autoconf
root# make clean
root# rm config.cache
root# ./configure
root# make
root# make install
```

This will, by default, install SAMBA in `/usr/local/samba`. See the main SAMBA documentation if you want to install SAMBA somewhere else. It will also build the `winbindd` executable and libraries.

21.5.3.2. Configure `nsswitch.conf` and the `winbind` libraries on Linux and Solaris

The libraries needed to run the `winbindd` daemon through `nsswitch` need to be copied to their proper locations, so

```
root# cp ../samba/source/nsswitch/libnss_winbind.so /lib
```

I also found it necessary to make the following symbolic link:

```
root# ln -s /lib/libnss_winbind.so /lib/libnss_winbind.so.2
```

And, in the case of Sun solaris:

```
root# ln -s /usr/lib/libnss_winbind.so /usr/lib/libnss_winbind.so.1
root# ln -s /usr/lib/libnss_winbind.so /usr/lib/nss_winbind.so.1
root# ln -s /usr/lib/libnss_winbind.so /usr/lib/nss_winbind.so.2
```

Now, as root you need to edit `/etc/nsswitch.conf` to allow user and group entries to be visible from the `winbindd` daemon. My `/etc/nsswitch.conf` file look like this after editing:

```
passwd:      files winbind
shadow:      files
group:       files winbind
```

The libraries needed by the `winbind` daemon will be automatically entered into the **ldconfig** cache the next time your system reboots, but it is faster (and you don't need to reboot) if you do it manually:

```
root# /sbin/ldconfig -v — grep winbind
```

This makes `libnss_winbind` available to `winbindd` and echos back a check to you.

21.5.3.3. NSS Winbind on AIX

(This section is only for those running AIX)

The `winbind` AIX identification module gets built as `libnss_winbind.so` in the `nsswitch` directory of the `samba` source. This file can be copied to `/usr/lib/security`, and the AIX naming convention would indicate that it should be named `WINBIND`. A stanza like the following:

```
WINBIND:
    program = /usr/lib/security/WINBIND
```

```
options = authonly
```

can then be added to `/usr/lib/security/methods.cfg`. This module only supports identification, but there have been success reports using the standard winbind pam module for authentication. Use caution configuring loadable authentication modules as it is possible to make it impossible to logon to the system. More information about the AIX authentication module API can be found at "Kernel Extensions and Device Support Programming Concepts for AIX": [Chapter 18. Loadable Authentication Module Programming Interface](#) and more information on administering the modules at "System Management Guide: Operating System and Devices".

21.5.3.4. Configure smb.conf

Several parameters are needed in the `smb.conf` file to control the behavior of `winbindd`. Configure `smb.conf` These are described in more detail in the `winbindd(8)` man page. My `smb.conf` file was modified to include the following entries in the `[global]` section:

```
[global]
<...>
# separate domain and username with '+', like DOMAIN+username
winbind separator = +
# use uids from 10000 to 20000 for domain users
winbind uid = 10000-20000
# use gids from 10000 to 20000 for domain groups
winbind gid = 10000-20000
# allow enumeration of winbind users and groups
winbind enum users = yes
winbind enum groups = yes
# give winbind users a real shell (only needed if they have telnet access)
template homedir = /home/winnt/%D/%U
template shell = /bin/bash
```

21.5.3.5. Join the SAMBA server to the PDC domain

Enter the following command to make the SAMBA server join the PDC domain, where `DOMAIN` is the name of your Windows domain and `Administrator` is a domain user who has administrative privileges in the domain.

```
root#/usr/local/samba/bin/net join -S PDC -U Administrator
```

The proper response to the command should be: "Joined the domain `DOMAIN`" where `DOMAIN` is your `DOMAIN` name.

21.5.3.6. Start up the winbindd daemon and test it!

Eventually, you will want to modify your `smb` startup script to automatically invoke the `winbindd` daemon when the other parts of SAMBA start, but it is possible to test out just the winbind portion first. To start up winbind services, enter the following command as root:

```
root#/usr/local/samba/bin/winbindd
```

Winbindd can now also run in 'dual daemon mode'. This will make it run as 2 processes. The first will answer all requests from the cache, thus making responses to clients faster. The other will update the cache for the query that the first has just

responded. Advantage of this is that responses stay accurate and are faster. You can enable dual daemon mode by adding `-B` to the commandline:

```
root#/usr/local/samba/bin/winbindd -B
```

I'm always paranoid and like to make sure the daemon is really running...

```
root#ps -ae -- grep winbindd
```

This command should produce output like this, if the daemon is running

```
3025 ?          00:00:00 winbindd
```

Now... for the real test, try to get some information about the users on your PDC

```
root#/usr/local/samba/bin/wbinfo -u
```

This should echo back a list of users on your Windows users on your PDC. For example, I get the following response:

```
CEO+Administrator
CEO+burdell
CEO+Guest
CEO+jt-ad
CEO+krbtgt
CEO+TsInternetUser
```

Obviously, I have named my domain 'CEO' and my winbind separator is '+'.
You can do the same sort of thing to get group information from the PDC:

```
root# /usr/local/samba/bin/wbinfo -g
```

```
CEO+Domain Admins
CEO+Domain Users
CEO+Domain Guests
CEO+Domain Computers
CEO+Domain Controllers
CEO+Cert Publishers
CEO+Schema Admins
CEO+Enterprise Admins
CEO+Group Policy Creator Owners
```

The function 'getent' can now be used to get unified lists of both local and PDC users and groups. Try the following command:

```
root#getent passwd
```

You should get a list that looks like your `/etc/passwd` list followed by the domain users with their new uids, gids, home directories and default shells.

The same thing can be done for groups with the command

```
root#getent group
```

21.5.3.7. Fix the `init.d` startup scripts

Linux The `winbindd` daemon needs to start up after the `smbd` and `nmbd` daemons are running. To accomplish this task, you need to modify the startup scripts of your system. They are located at `/etc/init.d/smb` in RedHat and `/etc/init.d/samba` in Debian. script to add commands to invoke this daemon in the proper sequence. My startup script starts up `smbd`, `nmbd`, and `winbindd` from the `/usr/local/samba/bin` directory directly. The 'start' function in the script looks like this:

```
start() {
    KIND="SMB"
    echo -n "Starting $KIND services: "
    daemon /usr/local/samba/bin/smbd $SMBDOPTIONS
    RETVAL=$?
    echo
    KIND="NMB"
    echo -n "Starting $KIND services: "
    daemon /usr/local/samba/bin/nmbd $NMBDOPTIONS
    RETVAL2=$?
    echo
    KIND="Winbind"
    echo -n "Starting $KIND services: "
    daemon /usr/local/samba/bin/winbindd
    RETVAL3=$?
    echo
    [ $RETVAL -eq 0 -a $RETVAL2 -eq 0 -a $RETVAL3 -eq 0 ] && \
touch /var/lock/subsys/smb || RETVAL=1
    return $RETVAL
}
```

If you would like to run winbindd in dual daemon mode, replace the line

```
daemon /usr/local/samba/bin/winbindd
```

in the example above with:

```
daemon /usr/local/samba/bin/winbindd -B
```

The 'stop' function has a corresponding entry to shut down the services and looks like this:

```
stop() {
    KIND="SMB"
    echo -n "Shutting down $KIND services: "
    killproc smbd
    RETVAL=$?
    echo
    KIND="NMB"
    echo -n "Shutting down $KIND services: "
    killproc nmbd
    RETVAL2=$?
    echo
    KIND="Winbind"
    echo -n "Shutting down $KIND services: "
    killproc winbindd
    RETVAL3=$?
    [ $RETVAL -eq 0 -a $RETVAL2 -eq 0 -a $RETVAL3 -eq 0 ] && \
rm -f /var/lock/subsys/smb
    echo ""
}
```

```
        return $RETVAL
    }
}
```

Solaris Winbind doesn't work on solaris 9, see the [Portability](#) chapter for details.

On solaris, you need to modify the `/etc/init.d/samba.server` startup script. It usually only starts `smbd` and `nmbd` but should now start `winbindd` too. If you have samba installed in `/usr/local/samba/bin`, the file could contains something like this:

```
##
## samba.server
##

if [ ! -d /usr/bin ]
then          # /usr not mounted
    exit
fi

killproc() {          # kill the named process(es)
    pid='/usr/bin/ps -e |
        /usr/bin/grep -w $1 |
        /usr/bin/sed -e 's/^ *//' -e 's/ .*//''
    [ "$pid" != "" ] && kill $pid
}

# Start/stop processes required for samba server

case "$1" in

'start')
#
# Edit these lines to suit your installation (paths, workgroup, host)
#
echo Starting SMBD
    /usr/local/samba/bin/smbd -D -s \
    /usr/local/samba/smb.conf

echo Starting NMBD
    /usr/local/samba/bin/nmbd -D -l \
    /usr/local/samba/var/log -s /usr/local/samba/smb.conf

echo Starting Winbind Daemon
    /usr/local/samba/bin/winbindd
    ;;

'stop')
    killproc nmbd
    killproc smbd
    killproc winbindd
    ;;

```

```
*)
    echo "Usage: /etc/init.d/samba.server { start | stop }"
    ;;
esac
```

Again, if you would like to run samba in dual daemon mode, replace

```
/usr/local/samba/bin/winbindd
```

in the script above with:

```
/usr/local/samba/bin/winbindd -B
```

Restarting If you restart the `smbd`, `nmbd`, and `winbindd` daemons at this point, you should be able to connect to the samba server as a domain member just as if you were a local user.

21.5.3.8. Configure Winbind and PAM

If you have made it this far, you know that `winbindd` and `samba` are working together. If you want to use `winbind` to provide authentication for other services, keep reading. The `pam` configuration files need to be altered in this step. (Did you remember to make backups of your original `/etc/pam.d` files? If not, do it now.)

You will need a `pam` module to use `winbindd` with these other services. This module will be compiled in the `../source/nsswitch` directory by invoking the command

```
root#make nsswitch/pam_winbind.so
```

from the `../source` directory. The `pam_winbind.so` file should be copied to the location of your other `pam` security modules. On my RedHat system, this was the `/lib/security` directory. On Solaris, the `pam` security modules reside in `/usr/lib/security`.

```
root#cp ../samba/source/nsswitch/pam_winbind.so /lib/security
```

Linux/FreeBSD-specific PAM configuration The `/etc/pam.d/samba` file does not need to be changed. I just left this file as it was:

```
auth    required    /lib/security/pam_stack.so service=system-auth
account required    /lib/security/pam_stack.so service=system-auth
```

The other services that I modified to allow the use of `winbind` as an authentication service were the normal login on the console (or a terminal session), `telnet` logins, and `ftp` service. In order to enable these services, you may first need to change the entries in `/etc/xinetd.d` (or `/etc/inetd.conf`). RedHat 7.1 uses the new `xinetd.d` structure, in this case you need to change the lines in `/etc/xinetd.d/telnet` and `/etc/xinetd.d/wu-ftp` from

```
enable = no
```

to

```
enable = yes
```

For ftp services to work properly, you will also need to either have individual directories for the domain users already present on the server, or change the home directory template to a general directory for all domain users. These can be easily set using the `smb.conf` global entry template `homedir`.

The `/etc/pam.d/ftp` file can be changed to allow winbind ftp access in a manner similar to the samba file. My `/etc/pam.d/ftp` file was changed to look like this:

```
auth      required      /lib/security/pam_listfile.so item=user sense=deny \
          file=/etc/ftpusers onerr=succeed
auth      sufficient    /lib/security/pam_winbind.so
auth      required      /lib/security/pam_stack.so service=system-auth
auth      required      /lib/security/pam_shells.so
account   sufficient    /lib/security/pam_winbind.so
account   required      /lib/security/pam_stack.so service=system-auth
session   required      /lib/security/pam_stack.so service=system-auth
```

The `/etc/pam.d/login` file can be changed nearly the same way. It now looks like this:

```
auth      required      /lib/security/pam_securetty.so
auth      sufficient    /lib/security/pam_winbind.so
auth      sufficient    /lib/security/pam_unix.so use_first_pass
auth      required      /lib/security/pam_stack.so service=system-auth
auth      required      /lib/security/pam_nologin.so
account   sufficient    /lib/security/pam_winbind.so
account   required      /lib/security/pam_stack.so service=system-auth
password  required      /lib/security/pam_stack.so service=system-auth
session   required      /lib/security/pam_stack.so service=system-auth
session   optional      /lib/security/pam_console.so
```

In this case, I added the
`auth sufficient /lib/security/pam_winbind.so`
lines as before, but also added the
`required pam_securetty.so`

above it, to disallow root logins over the network. I also added a **sufficient** `/lib/security/pam_unix.so use_first_pass` line after the **winbind.so** line to get rid of annoying double prompts for passwords.

Solaris-specific configuration The `/etc/pam.conf` needs to be changed. I changed this file so that my Domain users can logon both locally as well as telnet. The following are the changes that I made. You can customize the `pam.conf` file as per your requirements, but be sure of those changes because in the worst case it will leave your system nearly impossible to boot.

```
#
#ident    "@(#)pam.conf  1.14  99/09/16  SMI"
#
# Copyright (c) 1996-1999, Sun Microsystems, Inc.
```

```
# All Rights Reserved.
#
# PAM configuration
#
# Authentication management
#
login  auth required  /usr/lib/security/pam_winbind.so
login  auth required  /usr/lib/security/$ISA/pam_unix.so.1 try_first_pass
login  auth required  /usr/lib/security/$ISA/pam_dial_auth.so.1 try_first_pass
#
rlogin auth sufficient /usr/lib/security/pam_winbind.so
rlogin auth sufficient /usr/lib/security/$ISA/pam_rhosts_auth.so.1
rlogin  auth required  /usr/lib/security/$ISA/pam_unix.so.1 try_first_pass
#
dtlogin auth sufficient /usr/lib/security/pam_winbind.so
dtlogin auth required  /usr/lib/security/$ISA/pam_unix.so.1 try_first_pass
#
rsh    auth required  /usr/lib/security/$ISA/pam_rhosts_auth.so.1
other  auth sufficient /usr/lib/security/pam_winbind.so
other  auth required  /usr/lib/security/$ISA/pam_unix.so.1 try_first_pass
#
# Account management
#
login  account sufficient      /usr/lib/security/pam_winbind.so
login  account requisite /usr/lib/security/$ISA/pam_roles.so.1
login  account required  /usr/lib/security/$ISA/pam_unix.so.1
#
dtlogin account sufficient      /usr/lib/security/pam_winbind.so
dtlogin account requisite /usr/lib/security/$ISA/pam_roles.so.1
dtlogin account required  /usr/lib/security/$ISA/pam_unix.so.1
#
other  account sufficient      /usr/lib/security/pam_winbind.so
other  account requisite /usr/lib/security/$ISA/pam_roles.so.1
other  account required  /usr/lib/security/$ISA/pam_unix.so.1
#
# Session management
#
other session required  /usr/lib/security/$ISA/pam_unix.so.1
#
# Password management
#
#other  password sufficient      /usr/lib/security/pam_winbind.so
other  password required /usr/lib/security/$ISA/pam_unix.so.1
dtlogin auth required /usr/lib/security/$ISA/pam_unix.so.1
#
# Support for Kerberos V5 authentication (uncomment to use Kerberos)
#
#rlogin auth optional /usr/lib/security/$ISA/pam_krb5.so.1 try_first_pass
#login  auth optional /usr/lib/security/$ISA/pam_krb5.so.1 try_first_pass
#dtlogin auth optional /usr/lib/security/$ISA/pam_krb5.so.1 try_first_pass
#other  auth optional /usr/lib/security/$ISA/pam_krb5.so.1 try_first_pass
#dtlogin account optional /usr/lib/security/$ISA/pam_krb5.so.1
```



```
#other    account optional /usr/lib/security/$ISA/pam_krb5.so.1
#other    session optional /usr/lib/security/$ISA/pam_krb5.so.1
#other    password optional /usr/lib/security/$ISA/pam_krb5.so.1 try_first_pass
```

I also added a `try_first_pass` line after the `winbind.so` line to get rid of annoying double prompts for passwords.

Now restart your Samba and try connecting through your application that you configured in the `pam.conf`.

21.6. Conclusion

The winbind system, through the use of the Name Service Switch, Pluggable Authentication Modules, and appropriate Microsoft RPC calls have allowed us to provide seamless integration of Microsoft Windows NT domain users on a UNIX system. The result is a great reduction in the administrative cost of running a mixed UNIX and NT network.

21.7. Common Errors

Winbind has a number of limitations in its current released version that we hope to overcome in future releases:

- Winbind is currently only available for the Linux, Solaris and IRIX operating systems, although ports to other operating systems are certainly possible. For such ports to be feasible, we require the C library of the target operating system to support the Name Service Switch and Pluggable Authentication Modules systems. This is becoming more common as NSS and PAM gain support among UNIX vendors.
- The mappings of Windows NT RIDs to UNIX ids is not made algorithmically and depends on the order in which unmapped users or groups are seen by winbind. It may be difficult to recover the mappings of rid to UNIX id mapping if the file containing this information is corrupted or destroyed.
- Currently the winbind PAM module does not take into account possible workstation and logon time restrictions that may be been set for Windows NT users, this is instead up to the PDC to enforce.

22. Advanced Network Management

This section documents peripheral issues that are of great importance to network administrators who want to improve network resource access control, to automate the user environment, and to make their lives a little easier.

22.1. Features and Benefits

Often the difference between a working network environment and a well appreciated one can best be measured by the *little things* that makes everything work more harmoniously. A key part of every network environment solution is the ability to remotely manage MS Windows workstations, to remotely access the Samba server, to provide customised logon scripts, as well as other house keeping activities that help to sustain more reliable network operations.

This chapter presents information on each of these area. They are placed here, and not in other chapters, for ease of reference.

22.2. Remote Server Administration

How do I get 'User Manager' and 'Server Manager'?

Since I don't need to buy an NT4 Server, how do I get the 'User Manager for Domains', the 'Server Manager'?

Microsoft distributes a version of these tools called nexus for installation on Windows 9x / Me systems. The tools set includes:

- Server Manager
- User Manager for Domains
- Event Viewer

Click here to download the archived file <ftp://ftp.microsoft.com/Softlib/MSLFILES/NEXUS.EXE>

The Windows NT 4.0 version of the 'User Manager for Domains' and 'Server Manager' are available from Microsoft via ftp from <ftp://ftp.microsoft.com/Softlib/MSLFILES/SRVTOOLS.EXE>

22.3. Remote Desktop Management

There are a number of possible remote desktop management solutions that range from free through costly. Do not let that put you off. Sometimes the most costly solutions is the most cost effective. In any case, you will need to draw your own conclusions as to which is the best tool in your network environment.

22.3.1. Remote Management from NoMachines.Com

The following information was posted to the Samba mailing list at Apr 3 23:33:50 GMT 2003. It is presented in slightly edited form (with author details omitted for privacy reasons). The entire answer is reproduced below with some comments removed.

```
> I have a wonderful linux/samba server running as pdc for a network.  
> Now I would like to add remote desktop capabilities so that  
> users outside could login to the system and get their desktop up from  
> home or another country..  
>  
> Is there a way to accomplish this? Do I need a windows terminal server?  
> Do I need to configure it so that it is a member of the domain or a  
> BDC,PDC? Are there any hacks for MS Windows XP to enable remote login  
> even if the computer is in a domain?  
>  
> Any ideas/experience would be appreciated :)
```

Answer provided: Check out the new offer from NoMachine, "NX" software: <http://www.nomachine.com/>.

It implements a very easy-to-use interface to the remote X protocol as well as incorporating VNC/RFB and rdesktop/RDP into it, but at a speed performance much better than anything you may have ever seen...

Remote X is not new at all – but what they did achieve successfully is a new way of compression and caching technologies which makes the thing fast enough to run even over slow modem/ISDN connections.

I could testdrive their (public) RedHat machine in Italy, over a loaded internet connection, with enabled thumbnail previews in KDE konqueror which popped up immediately on "mouse-over". From inside that (remote X) session I started a rdesktop session on another, a Windows XP machine. To test the performance, I played Pinball. I am proud to announce here that my score was 631750 points at first try...

NX performs better on my local LAN than any of the other "pure" connection methods I am using from time to time: TightVNC, rdesktop or remote X. It is even faster than a direct crosslink connection between two nodes.

I even got sound playing from the remote X app to my local boxes, and had a working "copy'n'paste" from an NX window (running a KDE session in Italy) to my Mozilla mailing agent... These guys are certainly doing something right!

I recommend to testdrive NX to anybody with a only a remote interest in remote computing <http://www.nomachine.com/testdrive.php>.

Just download the free of charge client software (available for RedHat, SuSE, Debian and Windows) and be up and running within 5 minutes (they need to send you your account data, though, because you are assigned a real Unix account on their testdrive.nomachine.com box...

They plan to get to the point where you can have NX application servers running as a cluster of nodes, and users simply start an NX session locally, and can select applications to run transparently (apps may even run on another NX node, but pretend to be on the same as used for initial login, because it displays in the same window.... well, you also can run it fullscreen, and after a short time you forget that it is a remote session at all).

Now the best thing at the end: all the core compression and caching technologies are released under the GPL and available as source code to anybody who wants to build on it! These technologies are working, albeit started from the command line only (and very inconvenient to use in order to get a fully running remote X session up and running....)

To answer your questions:

- You don't need to install a terminal server; XP has RDP support built in.

- NX is much cheaper than Citrix – and comparable in performance, probably faster
- You don't need to hack XP – it just works
- You log into the XP box from remote transparently (and I think there is no need to change anything to get a connection, even if authentication is against a domain)
- The NX core technologies are all Open Source and released under the GPL – you can today use a (very inconvenient) commandline to use it at no cost, but you can buy a comfortable (proprietary) NX GUI frontend for money
- NoMachine are encouraging and offering help to OSS/Free Software implementations for such a frontend too, even if it means competition to them (they have written to this effect even to the LTSP, KDE and GNOME developer mailing lists)

22.4. Network Logon Script Magic

This section needs work. Volunteer contributions most welcome. Please send your patches or updates to [John Terpstra](#).

There are several opportunities for creating a custom network startup configuration environment.

No Logon Script

Simple universal Logon Script that applies to all users

Use of a conditional Logon Script that applies per user or per group attributes

Use of Samba's Preexec and Postexec functions on access to the NETLOGON share to create a custom Logon Script and then execute it.

User of a tool such as KixStart

The Samba source code tree includes two logon script generation/execution tools. See `examples` directory `genlogon` and `ntlogon` subdirectories.

The following listings are from the `genlogon` directory.

This is the `genlogon.pl` file:

```
#!/usr/bin/perl
#
# genlogon.pl
#
# Perl script to generate user logon scripts on the fly, when users
# connect from a Windows client. This script should be called from smb.conf
# with the %U, %G and %L parameters. I.e:
#
#     root preexec = genlogon.pl %U %G %L
#
# The script generated will perform
# the following:
#
# 1. Log the user connection to /var/log/samba/netlogon.log
# 2. Set the PC's time to the Linux server time (which is maintained
#    daily to the National Institute of Standard's Atomic clock on the
#    internet.
# 3. Connect the user's home drive to H: (H for Home).
# 4. Connect common drives that everyone uses.
# 5. Connect group-specific drives for certain user groups.
```

```
# 6. Connect user-specific drives for certain users.
# 7. Connect network printers.

# Log client connection
#($sec,$min,$hour,$mday,$mon,$year,$wday,$yday,$isdst) = localtime(time);
($sec,$min,$hour,$mday,$mon,$year,$wday,$yday,$isdst) = localtime(time);
open LOG, ">>/var/log/samba/netlogon.log";
print LOG "$mon/$mday/$year $hour:$min:$sec - User $ARGV[0] logged into $ARGV[1]\n";
close LOG;

# Start generating logon script
open LOGON, ">/shared/netlogon/$ARGV[0].bat";
print LOGON "\@ECHO OFF\r\n";

# Connect shares just use by Software Development group
if ($ARGV[1] eq "SOFTDEV" || $ARGV[0] eq "softdev")
{
    print LOGON "NET USE M: \\$ARGV[2]\SOURCE\r\n";
}

# Connect shares just use by Technical Support staff
if ($ARGV[1] eq "SUPPORT" || $ARGV[0] eq "support")
{
    print LOGON "NET USE S: \\$ARGV[2]\SUPPORT\r\n";
}

# Connect shares just used by Administration staff
If ($ARGV[1] eq "ADMIN" || $ARGV[0] eq "admin")
{
    print LOGON "NET USE L: \\$ARGV[2]\ADMIN\r\n";
    print LOGON "NET USE K: \\$ARGV[2]\MKTING\r\n";
}

# Now connect Printers. We handle just two or three users a little
# differently, because they are the exceptions that have desktop
# printers on LPT1: - all other user's go to the LaserJet on the
# server.
if ($ARGV[0] eq 'jim'
    || $ARGV[0] eq 'yvonne')
{
    print LOGON "NET USE LPT2: \\$ARGV[2]\LJET3\r\n";
    print LOGON "NET USE LPT3: \\$ARGV[2]\FAXQ\r\n";
}
else
{
    print LOGON "NET USE LPT1: \\$ARGV[2]\LJET3\r\n";
    print LOGON "NET USE LPT3: \\$ARGV[2]\FAXQ\r\n";
}

# All done! Close the output file.
close LOGON;
```

Those wishing to use more elaborate or capable logon processing system should check out the following sites:

<http://www.craigelachie.org/rhacer/ntlogon>

<http://www.kixtart.org>

<http://support.microsoft.com/default.asp?scid=kb;en-us;189105>

22.4.1. Adding printers without user intervention

Printers may be added automatically during logon script processing through the use of:

```
rundll32 printui.dll,PrintUIEntry /?
```

See the documentation in the [Microsoft knowledgebase article no: 189105](#).

22.5. Common Errors

The information provided in this chapter has been reproduced from postings on the samba@samba.org mailing list. No implied endorsement or recommendation is offered. Administrators should conduct their own evaluation of alternatives and are encouraged to draw their own conclusions.

23. System and Account Policies

This chapter summarises the current state of knowledge derived from personal practice and knowledge from samba mailing list subscribers. Before reproduction of posted information effort has been made to validate the information provided. Where additional information was uncovered through this validation it is provided also.

23.1. Features and Benefits

When MS Windows NT3.5 was introduced the hot new topic was the ability to implement Group Policies for users and group. Then along came MS Windows NT4 and a few sites started to adopt this capability. How do we know that? By way of the number of "boobos" (or mistakes) administrators made and then requested help to resolve.

By the time that MS Windows 2000 and Active Directory was released, administrators got the message: Group Policies are a good thing! They can help reduce administrative costs and actually can help to create happier users. But adoption of the true potential of MS Windows 200x Active Directory and Group Policy Objects (GPOs) for users and machines were picked up on rather slowly. This was very obvious from the samba mailing list as in 2000 and 2001 there were very few postings regarding GPOs and how to replicate them in a Samba environment.

Judging by the traffic volume since mid 2002, GPOs have become a standard part of the deployment in many sites. This chapter reviews techniques and methods that can be used to exploit opportunities for automation of control over user desktops and network client workstations.

A tool new to Samba-3 may become an important part of the future Samba Administrators' arsenal. The **editreg** tool is described in this document.

23.2. Creating and Managing System Policies

Under MS Windows platforms, particularly those following the release of MS Windows NT4 and MS Windows 95) it is possible to create a type of file that would be placed in the NETLOGON share of a domain controller. As the client logs onto the network this file is read and the contents initiate changes to the registry of the client machine. This file allows changes to be made to those parts of the registry that affect users, groups of users, or machines.

For MS Windows 9x/Me this file must be called **Config.POL** and may be generated using a tool called **poledit.exe**, better known as the Policy Editor. The policy editor was provided on the Windows 98 installation CD, but disappeared again with the introduction of MS Windows Me (Millenium Edition). From comments from MS Windows network administrators it would appear that this tool became a part of the MS Windows Me Resource Kit.

MS Windows NT4 Server products include the *System Policy Editor* under the **Start -> Programs -> Administrative Tools** menu item. For MS Windows NT4 and later clients this file must be called **NTConfig.POL**.

New with the introduction of MS Windows 2000 was the Microsoft Management Console or MMC. This tool is the new wave in the ever changing landscape of Mi-

Microsoft methods for management of network access and security. Every new Microsoft product or technology seems to obsolete the old rules and to introduce newer and more complex tools and methods. To Microsoft's credit though, the MMC does appear to be a step forward, but improved functionality comes at a great price.

Before embarking on the configuration of network and system policies it is highly advisable to read the documentation available from Microsoft's web site regarding [Implementing Profiles and Policies in Windows NT 4.0 from http://www.microsoft.com/ntserver/mana](http://www.microsoft.com/ntserver/mana) available from Microsoft. There are a large number of documents in addition to this old one that should also be read and understood. Try searching on the Microsoft web site for "Group Policies".

What follows is a very brief discussion with some helpful notes. The information provided here is incomplete - you are warned.

23.2.1. Windows 9x/Me Policies

You need the Win98 Group Policy Editor to set Group Profiles up under Windows 9x/Me. It can be found on the Original full product Win98 installation CD under `tools/reskit/netadmin/poledit`. Install this using the Add/Remove Programs facility and then click on the 'Have Disk' tab.

Use the Group Policy Editor to create a policy file that specifies the location of user profiles and/or the My Documents etc. Then save these settings in a file called `Config.POL` that needs to be placed in the root of the [NETLOGON] share. If Win98 is configured to log onto the Samba Domain, it will automatically read this file and update the Win9x/Me registry of the machine as it logs on.

Further details are covered in the Win98 Resource Kit documentation.

If you do not take the right steps, then every so often Win9x/Me will check the integrity of the registry and will restore it's settings from the back-up copy of the registry it stores on each Win9x/Me machine. Hence, you will occasionally notice things changing back to the original settings.

Install the group policy handler for Win9x to pick up group policies. Look on the Win98 CD in `\tools\reskit\netadmin\poledit`. Install group policies on a Win9x client by double-clicking `groupopol.inf`. Log off and on again a couple of times and see if Win98 picks up group policies. Unfortunately this needs to be done on every Win9x/Me machine that uses group policies.

23.2.2. Windows NT4 Style Policy Files

To create or edit `ntconfig.pol` you must use the NT Server Policy Editor, `poledit.exe` which is included with NT4 Server but *not NT Workstation*. There is a Policy Editor on a NT4 Workstation but it is not suitable for creating *Domain Policies*. Further, although the Windows 95 Policy Editor can be installed on an NT4 Workstation/Server, it will not work with NT clients. However, the files from the NT Server will run happily enough on an NT4 Workstation.

You need `poledit.exe`, `common.adm` and `winnt.adm`. It is convenient to put the two *.adm files in the `c:\winnt\inf` directory which is where the binary will look for them unless told otherwise. Note also that that directory is normally 'hidden'.

The Windows NT policy editor is also included with the Service Pack 3 (and later) for Windows NT 4.0. Extract the files using `servicepackname /x`, i.e. that's `Nt4sp6ai.exe /x` for service pack 6a. The policy editor, `poledit.exe` and the associated template files (*.adm) should be extracted as well. It is also possible to download the policy template files for Office97 and get a copy of the policy editor. Another possible location is with the Zero Administration Kit available for download from Microsoft.

23.2.2.1. Registry Spoiling

With NT4 style registry based policy changes, a large number of settings are not automatically reversed as the user logs off. Since the settings that were in the NTConfig.POL file were applied to the client machine registry and that apply to the hive key HKEY_LOCAL_MACHINE are permanent until explicitly reversed. This is known as tattooing. It can have serious consequences down-stream and the administrator must be extremely careful not to lock out the ability to manage the machine at a later date.

23.2.3. MS Windows 200x / XP Professional Policies

Windows NT4 System policies allows setting of registry parameters specific to users, groups and computers (client workstations) that are members of the NT4 style domain. Such policy file will work with MS Windows 2000 / XP clients also.

New to MS Windows 2000 Microsoft introduced a new style of group policy that confers a superset of capabilities compared with NT4 style policies. Obviously, the tool used to create them is different, and the mechanism for implementing them is much changed.

The older NT4 style registry based policies are known as *Administrative Templates* in MS Windows 2000/XP Group Policy Objects (GPOs). The later includes ability to set various security configurations, enforce Internet Explorer browser settings, change and redirect aspects of the users' desktop (including: the location of My Documents files (directory), as well as intrinsics of where menu items will appear in the Start menu). An additional new feature is the ability to make available particular software Windows applications to particular users and/or groups.

Remember: NT4 policy files are named NTConfig.POL and are stored in the root of the NETLOGON share on the domain controllers. A Windows NT4 user enters a username, a password and selects the domain name to which the logon will attempt to take place. During the logon process the client machine reads the NTConfig.POL file from the NETLOGON share on the authenticating server, modifies the local registry values according to the settings in this file.

Windows 2K GPOs are very feature rich. They are NOT stored in the NETLOGON share, rather part of a Windows 200x policy file is stored in the Active Directory itself and the other part is stored in a shared (and replicated) volume called the SYSVOL folder. This folder is present on all Active Directory domain controllers. The part that is stored in the Active Directory itself is called the group policy container (GPC), and the part that is stored in the replicated share called SYSVOL is known as the group policy template (GPT).

With NT4 clients the policy file is read and executed upon only as each user logs onto the network. MS Windows 200x policies are much more complex - GPOs are processed and applied at client machine startup (machine specific part) and when the user logs onto the network the user specific part is applied. In MS Windows 200x style policy management each machine and/or user may be subject to any number of concurrently applicable (and applied) policy sets (GPOs). Active Directory allows the administrator to also set filters over the policy settings. No such equivalent capability exists with NT4 style policy files.

23.2.3.1. Administration of Win2K / XP Policies

Instead of using the tool called The System Policy Editor, commonly called Poedit (from the executable name **poedit.exe**), GPOs are created and managed using a Microsoft Management Console (MMC) snap-in as follows:

1. Go to the Windows 200x / XP menu **Start->Programs->Administrative Tools** and select the MMC snap-in called **Active Directory Users and Computers**
2. Select the domain or organizational unit (OU) that you wish to manage, then right click to open the context menu for that object, select the properties item.
3. Now left click on the **Group Policy** tab, then left click on the New tab. Type a name for the new policy you will create.
4. Now left click on the **Edit** tab to commence the steps needed to create the GPO.

All policy configuration options are controlled through the use of policy administrative templates. These files have a .adm extension, both in NT4 as well as in Windows 200x / XP. Beware however, since the .adm files are NOT interchangeable across NT4 and Windows 200x. The later introduces many new features as well as extended definition capabilities. It is well beyond the scope of this documentation to explain how to program .adm files, for that the administrator is referred to the Microsoft Windows Resource Kit for your particular version of MS Windows.

NOTE

The MS Windows 2000 Resource Kit contains a tool called `gpolmig.exe`. This tool can be used to migrate an NT4 NTConfig.POL file into a Windows 200x style GPO. Be VERY careful how you use this powerful tool. Please refer to the resource kit manuals for specific usage information.

23.3. Managing Account/User Policies

Policies can define a specific user's settings or the settings for a group of users. The resulting policy file contains the registry settings for all users, groups, and computers that will be using the policy file. Separate policy files for each user, group, or computer are not necessary.

If you create a policy that will be automatically downloaded from validating domain controllers, you should name the file `NTconfig.POL`. As system administrator, you have the option of renaming the policy file and, by modifying the Windows NT-based workstation, directing the computer to update the policy from a manual path. You can do this by either manually changing the registry or by using the System Policy Editor. This path can even be a local path such that each machine has its own policy file, but if a change is necessary to all machines, this change must be made individually to each workstation.

When a Windows NT4/200x/XP machine logs onto the network the `NETLOGON` share on the authenticating domain controller for the presence of the `NTConfig.POL` file. If one exists it is downloaded, parsed and then applied to the user's part of the registry.

MS Windows 200x/XP clients that log onto an MS Windows Active Directory security domain may additionally, acquire policy settings through Group Policy Objects (GPOs) that are defined and stored in Active Directory itself. The key benefit of using AS GPOs is that they impose no registry *spoiling* effect. This has considerable advantage compared with the use of `NTConfig.POL` (NT4) style policy updates.

In addition to user access controls that may be imposed or applied via system and/or group policies in a manner that works in conjunction with user profiles, the

user management environment under MS Windows NT4/200x/XP allows per domain as well as per user account restrictions to be applied. Common restrictions that are frequently used includes:

- Logon Hours
- Password Aging
- Permitted Logon from certain machines only
- Account type (Local or Global)
- User Rights

23.3.1. Samba Editreg Toolset

Describe in detail the benefits of **editreg** and how to use it.

23.3.2. Windows NT4/200x

The tools that may be used to configure these types of controls from the MS Windows environment are: The NT4 User Manager for domains, the NT4 System and Group Policy Editor, the registry editor (`regedt32.exe`). Under MS Windows 200x/XP this is done using the Microsoft Management Console (MMC) with appropriate "snap-ins", the registry editor, and potentially also the NT4 System and Group Policy Editor.

23.3.3. Samba PDC

With a Samba Domain Controller, the new tools for managing of user account and policy information includes: **smbpasswd**, **pdbedit**, **net**, **rpcclient**. The administrator should read the man pages for these tools and become familiar with their use.

23.4. System Startup and Logon Processing Overview

The following attempts to document the order of processing of system and user policies following a system reboot and as part of the user logon:

1. Network starts, then Remote Procedure Call System Service (RPCSS) and Multiple Universal Naming Convention Provider (MUP) start
2. Where Active Directory is involved, an ordered list of Group Policy Objects (GPOs) is downloaded and applied. The list may include GPOs that:
 - Apply to the location of machines in a Directory
 - Apply only when settings have changed
 - Depend on configuration of scope of applicability: local, site, domain, organizational unit, etc.No desktop user interface is presented until the above have been processed.
3. Execution of start-up scripts (hidden and synchronous by default).
4. A keyboard action to affect start of logon (Ctrl-Alt-Del).
5. User credentials are validated, User profile is loaded (depends on policy settings).
6. An ordered list of User GPOs is obtained. The list contents depends on what is configured in respect of:
 - Is user a domain member, thus subject to particular policies
 - Loopback enablement, and the state of the loopback policy (Merge or Replace)
 - Location of the Active Directory itself

- Has the list of GPOs changed. No processing is needed if not changed.
7. User Policies are applied from Active Directory. Note: There are several types.
 8. Logon scripts are run. New to Win2K and Active Directory, logon scripts may be obtained based on Group Policy objects (hidden and executed synchronously). NT4 style logon scripts are then run in a normal window.
 9. The User Interface as determined from the GPOs is presented. Note: In a Samba domain (like and NT4 Domain) machine (system) policies are applied at start-up, User policies are applied at logon.

23.5. Common Errors

Policy related problems can be very difficult to diagnose and even more difficult to rectify. The following collection demonstrates only basic issues.

23.5.1. Policy Does Not Work

Question: We have created the `config.pol` file and put it in the `NETLOGON` share. It has made no difference to our Win XP Pro machines, they just don't see it. IT worked fine with Win 98 but does not work any longer since we upgraded to Win XP Pro. Any hints?

ANSWER: Policy files are NOT portable between Windows 9x / Me and MS Windows NT4 / 200x / XP based platforms. You need to use the NT4 Group Policy Editor to create a file called `NTConfig.POL` so that it is in the correct format for your MS Windows XP Pro clients.

24. Desktop Profile Management

24.1. Features and Benefits

Roaming Profiles are feared by some, hated by a few, loved by many, and a Godsend for some administrators.

Roaming Profiles allow an administrator to make available a consistent user desktop as the user moves from one machine to another. This chapter provides much information regarding how to configure and manage Roaming Profiles.

While Roaming Profiles might sound like nirvana to some, they are a real and tangible problem to others. In particular, users of mobile computing tools, where often there may not be a sustained network connection, are often better served by purely Local Profiles. This chapter provides information to help the Samba administrator to deal with those situations also.

24.2. Roaming Profiles

WARNING



Roaming profiles support is different for Win9x / Me and Windows NT4/200x.

Before discussing how to configure roaming profiles, it is useful to see how Windows 9x / Me and Windows NT4/200x clients implement these features.

Windows 9x / Me clients send a NetUserGetInfo request to the server to get the user's profiles location. However, the response does not have room for a separate profiles location field, only the user's home share. This means that Win9X/Me profiles are restricted to being stored in the user's home directory.

Windows NT4/200x clients send a NetSAMLogon RPC request, which contains many fields, including a separate field for the location of the user's profiles.

24.2.1. Samba Configuration for Profile Handling

This section documents how to configure Samba for MS Windows client profile support.

24.2.1.1. NT4/200x User Profiles

To support Windows NT4/200x clients, in the [global] section of smb.conf set the following (for example):

```
logon path = \\profiles\profiles\profilepath\%U\moreprofilepath
```

This is typically implemented like:

```
logon path = \\%L\Profiles\%u
```

where %L translates to the name of the Samba server and %u translates to the user name

The default for this option is `\\%N%U\profile`, namely `\\sambaserver\username\profile`. The `\\N%U` service is created automatically by the `[homes]` service. If you are using a samba server for the profiles, you *must* make the share specified in the logon path browseable. Please refer to the man page for `smb.conf` in respect of the different symantics of %L and %N, as well as %U and %u.

NOTE

MS Windows NT/2K clients at times do not disconnect a connection to a server between logons. It is recommended to NOT use the homes meta-service name as part of the profile share path.

24.2.1.2. Windows 9x / Me User Profiles

To support Windows 9x / Me clients, you must use the logon home parameter. Samba has now been fixed so that net use /home now works as well, and it, too, relies on the **logon home** parameter.

By using the logon home parameter, you are restricted to putting Win9x / Me profiles in the user's home directory. But wait! There is a trick you can use. If you set the following in the `[global]` section of your `smb.conf` file:

```
logon home = \\%L%U\.profiles
```

then your Windows 9x / Me clients will dutifully put their clients in a subdirectory of your home directory called `.profiles` (thus making them hidden).

Not only that, but net use /home will also work, because of a feature in Windows 9x / Me. It removes any directory stuff off the end of the home directory area and only uses the server and share portion. That is, it looks like you specified `\\%L%U` for logon home.

24.2.1.3. Mixed Windows 9x / Me and Windows NT4/200x User Profiles

You can support profiles for both Win9X and WinNT clients by setting both the logon home and logon path parameters. For example:

```
logon home = \\%L%u\.profiles
logon path = \\%L\profiles\%u
```

24.2.1.4. Disabling Roaming Profile Support

A question often asked is 'How may I enforce use of local profiles?' or 'How do I disable Roaming Profiles?'

There are three ways of doing this:

In `smb.conf` Affect the following settings and ALL clients will be forced to use a local profile:

```
logon home =  
logon path =
```

MS Windows Registry: By using the Microsoft Management Console `gpedit.msc` to instruct your MS Windows XP machine to use only a local profile. This of course modifies registry settings. The full path to the option is:

```
Local Computer Policy\  
  Computer Configuration\  
    Administrative Templates\  
      System\  
        User Profiles\  
          Disable: Only Allow Local User Profiles  
          Disable: Prevent Roaming Profile Change from Propogating to the Server
```

Change of Profile Type: From the start menu right click on the My Computer icon, select **Properties**, click on the **User Profiles** tab, select the profile you wish to change from Roaming type to Local, click **Change Type**.

Consult the MS Windows registry guide for your particular MS Windows version for more information about which registry keys to change to enforce use of only local user profiles.

NOTE



The specifics of how to convert a local profile to a roaming profile, or a roaming profile to a local one vary according to the version of MS Windows you are running. Consult the Microsoft MS Windows Resource Kit for your version of Windows for specific information.

24.2.2. Windows Client Profile Configuration Information

24.2.2.1. Windows 9x / Me Profile Setup

When a user first logs in on Windows 9X, the file `user.DAT` is created, as are folders `Start Menu`, `Desktop`, `Programs` and `Nethood`. These directories and their contents will be merged with the local versions stored in `c:\windows\profiles\username` on subsequent logins, taking the most recent from each. You will need to use the [global] options `preserve case = yes`, `short preserve case = yes` and `case sensitive = no` in order to maintain capital letters in shortcuts in any of the profile folders.

The `user.DAT` file contains all the user's preferences. If you wish to enforce a set of preferences, rename their `user.DAT` file to `user.MAN`, and deny them write access to this file.

1. On the Windows 9x / Me machine, go to **Control Panel** -> **Passwords** and select the **User Profiles** tab. Select the required level of roaming preferences. Press **OK**, but do `_not_` allow the computer to reboot.

2. On the Windows 9x / Me machine, go to **Control Panel -> Network -> Client for Microsoft Networks -> Preferences**. Select **Log on to NT Domain**. Then, ensure that the Primary Logon is **Client for Microsoft Networks**. Press **OK**, and this time allow the computer to reboot.

Under Windows 9x / Me Profiles are downloaded from the Primary Logon. If you have the Primary Logon as 'Client for Novell Networks', then the profiles and logon script will be downloaded from your Novell Server. If you have the Primary Logon as 'Windows Logon', then the profiles will be loaded from the local machine - a bit against the concept of roaming profiles, it would seem!

You will now find that the Microsoft Networks Login box contains [user, password, domain] instead of just [user, password]. Type in the samba server's domain name (or any other domain known to exist, but bear in mind that the user will be authenticated against this domain and profiles downloaded from it, if that domain logon server supports it), user name and user's password.

Once the user has been successfully validated, the Windows 9x / Me machine will inform you that **The user has not logged on before' and asks you if you wish to save the user's preferences?** Select **yes**.

Once the Windows 9x / Me client comes up with the desktop, you should be able to examine the contents of the directory specified in the logon path on the samba server and verify that the **Desktop, Start Menu, Programs** and **Nethood** folders have been created.

These folders will be cached locally on the client, and updated when the user logs off (if you haven't made them read-only by then). You will find that if the user creates further folders or short-cuts, that the client will merge the profile contents downloaded with the contents of the profile directory already on the local client, taking the newest folders and short-cuts from each set.

If you have made the folders / files read-only on the samba server, then you will get errors from the Windows 9x / Me machine on logon and logout, as it attempts to merge the local and the remote profile. Basically, if you have any errors reported by the Windows 9x / Me machine, check the Unix file permissions and ownership rights on the profile directory contents, on the samba server.

If you have problems creating user profiles, you can reset the user's local desktop cache, as shown below. When this user then next logs in, they will be told that they are logging in "for the first time".

1. instead of logging in under the [user, password, domain] dialog, press **escape**.
2. run the **regedit.exe** program, and look in:
`HKEY_LOCAL_MACHINE\Windows\CurrentVersion\ProfileList`
you will find an entry, for each user, of ProfilePath. Note the contents of this key (likely to be `c:\windows\profiles\username`), then delete the key ProfilePath for the required user.
[Exit the registry editor].
3. search for the user's .PWL password-caching file in the `c:\windows` directory, and delete it.
4. log off the windows 9x / Me client.
5. check the contents of the profile path (see logon path described above), and delete the `user.DAT` or `user.MAN` file for the user, making a backup if required.

If all else fails, increase samba's debug log levels to between 3 and 10, and / or run a packet trace program such as ethereal or **netmon.exe**, and look for error messages.

If you have access to an Windows NT4/200x server, then first set up roaming profiles and / or netlogons on the Windows NT4/200x server. Make a packet trace,

or examine the example packet traces provided with Windows NT4/200x server, and see what the differences are with the equivalent samba trace.

24.2.2.2. Windows NT4 Workstation

When a user first logs in to a Windows NT Workstation, the profile `NTuser.DAT` is created. The profile location can be now specified through the logon path parameter.

There is a parameter that is now available for use with NT Profiles: logon drive. This should be set to `H:` or any other drive, and should be used in conjunction with the new "logon home" parameter.

The entry for the NT4 profile is a `.directory_` not a file. The NT help on profiles mentions that a directory is also created with a `.PDS` extension. The user, while logging in, must have write permission to create the full profile path (and the folder with the `.PDS` extension for those situations where it might be created.)

In the profile directory, Windows NT4 creates more folders than Windows 9x / Me. It creates **Application Data** and others, as well as **Desktop**, **Nethood**, **Start Menu** and **Programs**. The profile itself is stored in a file `NTuser.DAT`. Nothing appears to be stored in the `.PDS` directory, and its purpose is currently unknown.

You can use the System Control Panel to copy a local profile onto a samba server (see NT Help on profiles: it is also capable of firing up the correct location in the System Control Panel for you). The NT Help file also mentions that renaming `NTuser.DAT` to `NTuser.MAN` turns a profile into a mandatory one.

The case of the profile is significant. The file must be called `NTuser.DAT` or, for a mandatory profile, `NTuser.MAN`.

24.2.2.3. Windows 2000/XP Professional

You must first convert the profile from a local profile to a domain profile on the MS Windows workstation as follows:

1. Log on as the *LOCAL* workstation administrator.
2. Right click on the **My Computer** Icon, select **Properties**
3. Click on the **User Profiles** tab
4. Select the profile you wish to convert (click on it once)
5. Click on the button **Copy To**
6. In the **Permitted to use** box, click on the **Change** button.
7. Click on the 'Look in" area that lists the machine name, when you click here it will open up a selection box. Click on the domain to which the profile must be accessible.

NOTE



You will need to log on if a logon box opens up. Eg: In the connect as: `MIDEARTH\root`, password: `mypassword`.

8. To make the profile capable of being used by anyone select 'Everyone'
9. Click **OK**. The Selection box will close.
10. Now click on the **Ok** button to create the profile in the path you nominated.
Done. You now have a profile that can be edited using the samba-3.0.0 **profiles** tool.

NOTE



Under NT/2K the use of mandatory profiles forces the use of MS Exchange storage of mail data. That keeps desktop profiles usable.

NOTE

1. This is a security check new to Windows XP (or maybe only Windows XP service pack 1). It can be disabled via a group policy in Active Directory. The policy is: Computer Configuration\Administrative Templates\System\User Profiles\Do not check for user ownership of Roaming Profile Folders...and it should be set to Enabled. Does the new version of samba have an Active Directory analogue? If so, then you may be able to set the policy through this. If you cannot set group policies in samba, then you may be able to set the policy locally on each machine. If you want to try this, then do the following (N.B. I don't know for sure that this will work in the same way as a domain group policy):
2. On the XP workstation log in with an Administrator account.
3. Click: **Start, Run**
4. Type: mmc
5. Click: **OK**
6. A Microsoft Management Console should appear.
7. Click: **File, Add/Remove Snap-in..., Add**
8. Double-Click: **Group Policy**
9. Click: **Finish, Close**
10. Click: **OK**
11. In the "Console Root" window:
12. Expand: **Local Computer Policy, Computer Configuration, Administrative Templates, System, User Profiles**
13. Double-Click: **Do not check for user ownership of Roaming Profile Folders**
14. Select: **Enabled**
15. Click: **OK**
16. Close the whole console. You do not need to save the settings (this refers to the console settings rather than the policies you have changed).
17. Reboot



24.2.3. Sharing Profiles between W9x/Me and NT4/200x/XP workstations

Sharing of desktop profiles between Windows versions is NOT recommended. Desktop profiles are an evolving phenomenon and profiles for later versions of MS Win-

dows clients add features that may interfere with earlier versions of MS Windows clients. Probably the more salient reason to NOT mix profiles is that when logging off an earlier version of MS Windows the older format of profile contents may overwrite information that belongs to the newer version resulting in loss of profile information content when that user logs on again with the newer version of MS Windows.

If you then want to share the same Start Menu / Desktop with W9x/Me, you will need to specify a common location for the profiles. The `smb.conf` parameters that need to be common are `logon path` and `logon home`.

If you have this set up correctly, you will find separate `user.DAT` and `NTuser.DAT` files in the same profile directory.

24.2.4. Profile Migration from Windows NT4/200x Server to Samba

There is nothing to stop you specifying any path that you like for the location of users' profiles. Therefore, you could specify that the profile be stored on a samba server, or any other SMB server, as long as that SMB server supports encrypted passwords.

24.2.4.1. Windows NT4 Profile Management Tools

Unfortunately, the Resource Kit information is specific to the version of MS Windows NT4/200x. The correct resource kit is required for each platform.

Here is a quick guide:

1. On your NT4 Domain Controller, right click on **My Computer**, then select the tab labelled **User Profiles**.
2. Select a user profile you want to migrate and click on it.

NOTE



I am using the term "migrate" loosely. You can copy a profile to create a group profile. You can give the user 'Everyone' rights to the profile you copy this to. That is what you need to do, since your samba domain is not a member of a trust relationship with your NT4 PDC.

3. Click the **Copy To** button.
4. In the box labelled **Copy Profile to** add your new path, eg: `c:\temp\foobar`
5. Click on the button **Change** in the **Permitted to use** box.
6. Click on the group 'Everyone' and then click **OK**. This closes the 'choose user' box.
7. Now click **OK**.

Follow the above for every profile you need to migrate.

24.2.4.2. Side bar Notes

You should obtain the SID of your NT4 domain. You can use `smbpasswd` to do this. Read the man page.

With Samba-3.0.0 alpha code you can import all you NT4 domain accounts using the `net samsync` method. This way you can retain your profile settings as well as all your users.

24.2.4.3. moveuser.exe

The W2K professional resource kit has moveuser.exe. moveuser.exe changes the security of a profile from one user to another. This allows the account domain to change, and/or the user name to change.

24.2.4.4. Get SID

You can identify the SID by using GetSID.exe from the Windows NT Server 4.0 Resource Kit.

Windows NT 4.0 stores the local profile information in the registry under the following key: `HKEY_LOCAL_MACHINE\SOFTWARE\Microsoft\Windows NT\CurrentVersion\ProfileList`

Under the ProfileList key, there will be subkeys named with the SIDs of the users who have logged on to this computer. (To find the profile information for the user whose locally cached profile you want to move, find the SID for the user with the GetSID.exe utility.) Inside of the appropriate user's subkey, you will see a string value named ProfileImagePath.

24.3. Mandatory profiles

A Mandatory Profile is a profile that the user does NOT have the ability to overwrite. During the user's session it may be possible to change the desktop environment, but as the user logs out all changes made will be lost. If it is desired to NOT allow the user any ability to change the desktop environment then this must be done through policy settings. See previous chapter.

NOTE



Under NO circumstances should the profile directory (or its contents) be made read-only as this may render the profile un-usable.

For MS Windows NT4/200x/XP the above method can be used to create mandatory profiles also. To convert a group profile into a mandatory profile simply locate the NTUser.DAT file in the copied profile and rename it to NTUser.MAN.

For MS Windows 9x / Me it is the User.DAT file that must be renamed to User.MAN to affect a mandatory profile.

24.4. Creating/Managing Group Profiles

Most organisations are arranged into departments. There is a nice benefit in this fact since usually most users in a department will require the same desktop applications and the same desktop layout. MS Windows NT4/200x/XP will allow the use of Group Profiles. A Group Profile is a profile that is created firstly using a template (example) user. Then using the profile migration tool (see above) the profile is assigned access rights for the user group that needs to be given access to the group profile.

The next step is rather important. *Please note:* Instead of assigning a group profile to users (ie: Using User Manager) on a "per user" basis, the group itself is assigned the now modified profile.

NOTE



Be careful with group profiles, if the user who is a member of a group also has a personal profile, then the result will be a fusion (merge) of the two.

24.5. Default Profile for Windows Users

MS Windows 9x / Me and NT4/200x/XP will use a default profile for any user for whom a profile does not already exist. Armed with a knowledge of where the default profile is located on the Windows workstation, and knowing which registry keys affect the path from which the default profile is created, it is possible to modify the default profile to one that has been optimised for the site. This has significant administrative advantages.

24.5.1. MS Windows 9x/Me

To enable default per use profiles in Windows 9x / Me you can either use the Windows 98 System Policy Editor or change the registry directly.

To enable default per user profiles in Windows 9x / Me, launch the System Policy Editor, then select **File -> Open Registry**, then click on the **Local Computer** icon, click on **Windows 98 System**, select **User Profiles**, click on the enable box. Do not forget to save the registry changes.

To modify the registry directly, launch the Registry Editor (**regedit.exe**), select the hive `HKEY_LOCAL_MACHINE\Network\Logon`. Now add a DWORD type key with the name "User Profiles", to enable user profiles set the value to 1, to disable user profiles set it to 0.

24.5.1.1. How User Profiles Are Handled in Windows 9x / Me?

When a user logs on to a Windows 9x / Me machine, the local profile path, `HKEY_LOCAL_MACHINE\Software` is checked for an existing entry for that user:

If the user has an entry in this registry location, Windows 9x / Me checks for a locally cached version of the user profile. Windows 9x / Me also checks the user's home directory (or other specified directory if the location has been modified) on the server for the User Profile. If a profile exists in both locations, the newer of the two is used. If the User Profile exists on the server, but does not exist on the local machine, the profile on the server is downloaded and used. If the User Profile only exists on the local machine, that copy is used.

If a User Profile is not found in either location, the Default User Profile from the Windows 9x / Me machine is used and is copied to a newly created folder for the logged on user. At log off, any changes that the user made are written to the user's local profile. If the user has a roaming profile, the changes are written to the user's profile on the server.

24.5.2. MS Windows NT4 Workstation

On MS Windows NT4 the default user profile is obtained from the location `%System-Root%\Profiles` which in a default installation will translate to `C:\WinNT\Profiles`.

Under this directory on a clean install there will be three (3) directories: **Administrator**, **All Users**, **Default User**.

The **All Users** directory contains menu settings that are common across all system users. The **Default User** directory contains menu entries that are customisable per user depending on the profile settings chosen/created.

When a new user first logs onto an MS Windows NT4 machine a new profile is created from:

- All Users settings

- Default User settings (contains the default NTUser.DAT file)

When a user logs onto an MS Windows NT4 machine that is a member of a Microsoft security domain the following steps are followed in respect of profile handling:

1. The users' account information which is obtained during the logon process contains the location of the users' desktop profile. The profile path may be local to the machine or it may be located on a network share. If there exists a profile at the location of the path from the user account, then this profile is copied to the location `%SystemRoot%\Profiles\%USERNAME%`. This profile then inherits the settings in the **All Users** profile in the `%SystemRoot%\Profiles` location.
2. If the user account has a profile path, but at its location a profile does not exist, then a new profile is created in the `%SystemRoot%\Profiles\%USERNAME%` directory from reading the **Default User** profile.
3. If the NETLOGON share on the authenticating server (logon server) contains a policy file (`NTConfig.POL`) then its contents are applied to the `NTUser.DAT` which is applied to the `HKEY_CURRENT_USER` part of the registry.
4. When the user logs out, if the profile is set to be a roaming profile it will be written out to the location of the profile. The `NTUser.DAT` file is then re-created from the contents of the `HKEY_CURRENT_USER` contents. Thus, should there not exist in the NETLOGON share an `NTConfig.POL` at the next logon, the effect of the previous `NTConfig.POL` will still be held in the profile. The effect of this is known as *tattooing*.

MS Windows NT4 profiles may be *Local* or *Roaming*. A Local profile will be stored in the `%SystemRoot%\Profiles\%USERNAME%` location. A roaming profile will also remain stored in the same way, unless the following registry key is created:

```
HKEY_LOCAL_MACHINE\SYSTEM\Software\Microsoft\Windows NT\CurrentVersion\winlogon\
>DeleteRoamingCache"=dword:00000001
```

In which case, the local copy (in `%SystemRoot%\Profiles\%USERNAME%`) will be deleted on logout.

Under MS Windows NT4 default locations for common resources (like **My Documents**) may be redirected to a network share by modifying the following registry keys. These changes may be affected via use of the System Policy Editor (to do so may require that you create your own template extension for the policy editor to allow this to be done through the GUI. Another way to do this is by way of first creating a default user profile, then while logged in as that user, run `regedt32` to edit the key settings.

The Registry Hive key that affects the behaviour of folders that are part of the default user profile are controlled by entries on Windows NT4 is:

```
HKEY_CURRENT_USER\Software\Microsoft\Windows\CurrentVersion\Explorer\User
Shell Folders\
```

The above hive key contains a list of automatically managed folders. The default entries are:

Table 24.1: User Shell Folder registry keys default values

Name	Default Value
AppData	%USERPROFILE%\Application Data
Desktop	%USERPROFILE%\Desktop
Favorites	%USERPROFILE%\Favorites
NetHood	%USERPROFILE%\NetHood
PrintHood	%USERPROFILE%\PrintHood
Programs	%USERPROFILE%\Start Menu\Programs
Recent	%USERPROFILE%\Recent
SendTo	%USERPROFILE%\SendTo
Start Menu	%USERPROFILE%\Start Menu
Startup	%USERPROFILE%\Start Menu\Programs\Startup

The registry key that contains the location of the default profile settings is:

HKEY_LOCAL_MACHINE\SOFTWARE\Microsoft\Windows\CurrentVersion\Explorer\User Shell Folders

The default entries are:

Table 24.2: Defaults of profile settings registry keys

Common Desktop	%SystemRoot%\Profiles\All Users\Desktop
Common Programs	%SystemRoot%\Profiles\All Users\Programs
Common Start Menu	%SystemRoot%\Profiles\All Users\Start Menu
Common Startup	%SystemRoot%\Profiles\All Users\Start Menu\Programs\Startup

24.5.3. MS Windows 200x/XP

NOTE



MS Windows XP Home Edition does use default per user profiles, but can not participate in domain security, can not log onto an NT/ADS style domain, and thus can obtain the profile only from itself. While there are benefits in doing this the beauty of those MS Windows clients that CAN participate in domain logon processes allows the administrator to create a global default profile and to enforce it through the use of Group Policy Objects (GPOs).

When a new user first logs onto MS Windows 200x/XP machine the default profile is obtained from C:\Documents and Settings\Default User. The administrator can modify (or change the contents of this location and MS Windows 200x/XP will gladly use it. This is far from the optimum arrangement since it will involve copying a new default profile to every MS Windows 200x/XP client workstation.

When MS Windows 200x/XP participate in a domain security context, and if the default user profile is not found, then the client will search for a default profile in the NETLOGON share of the authenticating server. ie: In MS Windows parlance: `%LOGONSERVER%\NETLOGON\Default User` and if one exists there it will copy this to the workstation to the `C:\Documents and Settings\` under the Windows login name of the user.

NOTE



This path translates, in Samba parlance, to the `smb.conf [NETLOGON]` share. The directory should be created at the root of this share and must be called `Default Profile`.

If a default profile does not exist in this location then MS Windows 200x/XP will use the local default profile.

On logging out, the users' desktop profile will be stored to the location specified in the registry settings that pertain to the user. If no specific policies have been created, or passed to the client during the login process (as Samba does automatically), then the user's profile will be written to the local machine only under the path `C:\Documents and Settings\%USERNAME%`.

Those wishing to modify the default behaviour can do so through three methods:

- Modify the registry keys on the local machine manually and place the new default profile in the NETLOGON share root - NOT recommended as it is maintenance intensive.
- Create an NT4 style NTConfig.POL file that specified this behaviour and locate this file in the root of the NETLOGON share along with the new default profile.
- Create a GPO that enforces this through Active Directory, and place the new default profile in the NETLOGON share.

The Registry Hive key that affects the behaviour of folders that are part of the default user profile are controlled by entries on Windows 200x/XP is:

```
HKEY_CURRENT_USER\Software\Microsoft\Windows\CurrentVersion\Explorer\User Shell Folders\
```

The above hive key contains a list of automatically managed folders. The default entries are:

There is also an entry called "Default" that has no value set. The default entry is of type `REG_SZ`, all the others are of type `REG_EXPAND_SZ`.

It makes a huge difference to the speed of handling roaming user profiles if all the folders are stored on a dedicated location on a network server. This means that it will NOT be necessary to write the Outlook PST file over the network for every login and logout.

To set this to a network location you could use the following examples:

```
%LOGONSERVER%\%USERNAME%\Default Folders
```

This would store the folders in the user's home directory under a directory called `Default Folders` You could also use:

```
\\SambaServer\FolderShare\%USERNAME%
```

in which case the default folders will be stored in the server named `SambaServer` in the share called `FolderShare` under a directory that has the name of the MS Windows user as seen by the Linux/Unix file system.

Please note that once you have created a default profile share, you MUST migrate a user's profile (default or custom) to it.

Table 24.3: Defaults of default user profile paths registry keys

Name	Default Value
AppData	%USERPROFILE%\Application Data
Cache	%USERPROFILE%\Local Settings\Temporary Internet Files
Cookies	%USERPROFILE%\Cookies
Desktop	%USERPROFILE%\Desktop
Favorites	%USERPROFILE%\Favorites
History	%USERPROFILE%\Local Settings\History
Local AppData	%USERPROFILE%\Local Settings\Application Data
Local Settings	%USERPROFILE%\Local Settings
My Pictures	%USERPROFILE%\My Documents\My Pictures
NetHood	%USERPROFILE%\NetHood
Personal	%USERPROFILE%\My Documents
PrintHood	%USERPROFILE%\PrintHood
Programs	%USERPROFILE%\Start Menu\Programs
Recent	%USERPROFILE%\Recent
SendTo	%USERPROFILE%\SendTo
Start Menu	%USERPROFILE%\Start Menu
Startup	%USERPROFILE%\Start Menu\Programs\Startup
Templates	%USERPROFILE%\Templates

MS Windows 200x/XP profiles may be *Local* or *Roaming*. A roaming profile will be cached locally unless the following registry key is created:

```
HKEY_LOCAL_MACHINE\SYSTEM\Software\Microsoft\Windows NT\CurrentVersion\winlogon\ "De
```

In which case, the local cache copy will be deleted on logout.

24.6. Common Errors

The following are some typical errors/problems/questions that have been asked.

24.6.1. How does one set up roaming profiles for just one (or a few) user/s or group/s?

With samba-2.2.x the choice you have is to enable or disable roaming profiles support. It is a global only setting. The default is to have roaming profiles and the default path will locate them in the user's home directory.

If disabled globally then no-one will have roaming profile ability. If enabled and you want it to apply only to certain machines, then on those machines on which roaming profile support is NOT wanted it is then necessary to disable roaming profile handling in the registry of each such machine.

With samba-3.0.0 (soon to be released) you can have a global profile setting in smb.conf *AND* you can over-ride this by per-user settings using the Domain User Manager (as with MS Windows NT4/ Win 2Kx).

In any case, you can configure only one profile per user. That profile can be either:

- A profile unique to that user

- A mandatory profile (one the user can not change)

A group profile (really should be mandatory ie:unchangable)

24.6.2. Can NOT use Roaming Profiles

'I dont want Roaming profile to be implemented, I just want to give users local profiles only. ... Please help me I am totally lost with this error from past two days I tried everything and googled around quite a bit but of no help. Please help me.'

Your choices are:

Local profiles I know of no registry keys that will allow auto-deletion of LOCAL profiles on log out

Roaming profiles

can use auto-delete on logout option
requires a registry key change on workstation

Your choices are:

Personal Roaming profiles - should be preserved on a central server - workstations 'cache' (store) a local copy - used in case the profile can not be downloaded at next logon

Group profiles - loaded from a cetral place

Mandatory profiles - can be personal or group - can NOT be changed (except by an administrator)

A WinNT4/2K/XP profile can vary in size from 130KB to off the scale. Outlook PST files are most often part of the profile and can be many GB in size. On average (in a well controlled environment) roaming profie size of 2MB is a good rule of thumb to use for planning purposes. In an undisciplined environment I have seen up to 2GB profiles. Users tend to complain when it take an hour to log onto a workstation but they harvest the fuits of folly (and ignorance).

The point of all the above is to show that roaming profiles and good controls of how they can be changed as well as good discipline make up for a problem free site.

Microsoft's answer to the PST problem is to store all email in an MS Exchange Server back-end. But this is another story ...!

So, having LOCAL profiles means:

If lots of users user each machine - lot's of local disk storage needed for local profiles

Every workstation the user logs into has it's own profile - can be very different from machine to machine

On the other hand, having roaming profiles means:

The network administrator can control EVERY aspect of user profiles

With the use of mandatory profiles - a drastic reduction in network management overheads

User unhappiness about not being able to change their profiles soon fades as they get used to being able to work reliably

I have managed and installed MANY NT/2K networks and have NEVER found one where users who move from machine to machine are happy with local profiles. In the long run local profiles bite them.

24.6.3. Changing the default profile

'When the client tries to logon to the PDC it looks for a profile to download where do I put this default profile.'

Firstly, your samba server need to be configured as a domain controller.

```
server = user
os level = 32 (or more)
domain logons = Yes
```

Plus you need to have a [netlogon] share that is world readable. It is a good idea to add a logon script to pre-set printer and drive connections. There is also a facility for automatically synchronizing the workstation time clock with that of the logon server (another good thing to do).

NOTE

To invoke auto-deletion of roaming profile from the local workstation cache (disk storage) you need to use the Group Policy Editor to create a file called `NTConfig.POL` with the appropriate entries. This file needs to be located in the netlogon share root directory.

Oh, of course the windows clients need to be members of the domain. Workgroup machines do NOT do network logons - so they never see domain profiles.

Secondly, for roaming profiles you need: logon path = `\\%N\profiles\%U` (with some such path) logon drive = H: (Z: is the default) Plus you need a `PROFILES` share that is world writable.

25. PAM based Distributed Authentication

This chapter you should help you to deploy winbind based authentication on any PAM enabled Unix/Linux system. Winbind can be used to enable user level application access authentication from any MS Windows NT Domain, MS Windows 200x Active Directory based domain, or any Samba based domain environment. It will also help you to configure PAM based local host access controls that are appropriate to your Samba configuration.

In addition to knowing how to configure winbind into PAM, you will learn generic PAM management possibilities and in particular how to deploy tools like `pam_smbpass.so` to your advantage.

NOTE



The use of Winbind require more than PAM configuration alone. Please refer to [the Winbind chapter](#).

25.1. Features and Benefits

A number of Unix systems (eg: Sun Solaris), as well as the xxxxBSD family and Linux, now utilize the Pluggable Authentication Modules (PAM) facility to provide all authentication, authorization and resource control services. Prior to the introduction of PAM, a decision to use an alternative to the system password database (`/etc/passwd`) would require the provision of alternatives for all programs that provide security services. Such a choice would involve provision of alternatives to such programs as: **login**, **passwd**, **chown**, etc.

PAM provides a mechanism that disconnects these security programs from the underlying authentication/authorization infrastructure. PAM is configured either through one file `/etc/pam.conf` (Solaris), or by editing individual files that are located in `/etc/pam.d`.

On PAM enabled Unix/Linux systems it is an easy matter to configure the system to use any authentication backend, so long as the appropriate dynamically loadable library modules are available for it. The backend may be local to the system, or may be centralised on a remote server.

PAM support modules are available for:

`/etc/passwd` -

There are several PAM modules that interact with this standard Unix user database. The most common are called: `pam_unix.so`, `pam_unix2.so`, `pam_pwdb.so` and `pam_userdb.so`.

Kerberos -

The `pam_krb5.so` module allows the use of any Kerberos compliant server. This tool is used to access MIT Kerberos, Heimdal Kerberos, and potentially

Microsoft Active Directory (if enabled).

LDAP -

The `pam_ldap.so` module allows the use of any LDAP v2 or v3 compatible backend server. Commonly used LDAP backend servers include: OpenLDAP v2.0 and v2.1, Sun ONE iIdentity server, Novell eDirectory server, Microsoft Active Directory.

NetWare Bindery -

The `pam_ncp_auth.so` module allows authentication off any bindery enabled NetWare Core Protocol based server.

SMB Password -

This module, called `pam_smbpass.so`, will allow user authentication off the `passwd` backend that is configured in the Samba `smb.conf` file.

SMB Server -

The `pam_smb_auth.so` module is the original MS Windows networking authentication tool. This module has been somewhat outdated by the `Winbind` module.

Winbind -

The `pam_winbind.so` module allows Samba to obtain authentication from any MS Windows Domain Controller. It can just as easily be used to authenticate users for access to any PAM enabled application.

RADIUS -

There is a PAM RADIUS (Remote Access Dial-In User Service) authentication module. In most cases the administrator will need to locate the source code for this tool and compile and install it themselves. RADIUS protocols are used by many routers and terminal servers.

Of the above, Samba provides the `pam_smbpasswd.so` and the `pam_winbind.so` modules alone.

Once configured, these permit a remarkable level of flexibility in the location and use of distributed samba domain controllers that can provide wide area network bandwidth efficient authentication services for PAM capable systems. In effect, this allows the deployment of centrally managed and maintained distributed authentication from a single user account database.

25.2. Technical Discussion

PAM is designed to provide the system administrator with a great deal of flexibility in configuration of the privilege granting applications of their system. The local configuration of system security controlled by PAM is contained in one of two places: either the single system file, `/etc/pam.conf`; or the `/etc/pam.d/` directory.

25.2.1. PAM Configuration Syntax

In this section we discuss the correct syntax of and generic options respected by entries to these files. PAM specific tokens in the configuration file are case insensitive. The module paths, however, are case sensitive since they indicate a file's name and reflect the case dependence of typical file-systems. The case-sensitivity of the arguments to any given module is defined for each module in turn.

In addition to the lines described below, there are two special characters provided for the convenience of the system administrator: comments are preceded by a `#` and extend to the next end-of-line; also, module specification lines may be extended with a `\` escaped newline.

If the PAM authentication module (loadable link library file) is located in the default location then it is not necessary to specify the path. In the case of Linux, the default location is `/lib/security`. If the module is located outside the default then the path must be specified as:

```
auth required /other_path/pam_strange_module.so
```

25.2.1.1. Anatomy of `/etc/pam.d` Entries

The remaining information in this subsection was taken from the documentation of the Linux-PAM project. For more information on PAM, see <http://ftp.kernel.org/pub/linux/libs/pam> The Official Linux-PAM home page.

A general configuration line of the `/etc/pam.conf` file has the following form:

```
service-name  module-type  control-flag  module-path  args
```

Below, we explain the meaning of each of these tokens. The second (and more recently adopted) way of configuring Linux-PAM is via the contents of the `/etc/pam.d/` directory. Once we have explained the meaning of the above tokens, we will describe this method.

service-name -

The name of the service associated with this entry. Frequently the service name is the conventional name of the given application. For example, 'ftpd', 'rlogind' and 'su', etc. .

There is a special service-name, reserved for defining a default authentication mechanism. It has the name 'OTHER' and may be specified in either lower or upper case characters. Note, when there is a module specified for a named service, the 'OTHER' entries are ignored.

module-type -

One of (currently) four types of module. The four types are as follows:

- *auth*: this module type provides two aspects of authenticating the user. Firstly, it establishes that the user is who they claim to be, by instructing the application to prompt the user for a password or other means of identification. Secondly, the module can grant group membership (independently of the `/etc/groups` file discussed above) or other privileges through its credential granting properties.
- *account*: this module performs non-authentication based account management. It is typically used to restrict/permit access to a service based on the time of day, currently available system resources (maximum number of users) or perhaps the location of the applicant user 'root' login only on the console.
- *session*: primarily, this module is associated with doing things that need to be done for the user before/after they can be given service. Such things include the logging of information concerning the opening/closing of some data exchange with a user, mounting directories, etc.
- *password*: this last module type is required for updating the authentication token associated with the user. Typically, there is one module for each 'challenge/response' based authentication (auth) module-type.

control-flag -

The control-flag is used to indicate how the PAM library will react to the success or failure of the module it is associated with. Since modules can be

stacked (modules of the same type execute in series, one after another), the control-flags determine the relative importance of each module. The application is not made aware of the individual success or failure of modules listed in the `/etc/pam.conf` file. Instead, it receives a summary success or fail response from the Linux-PAM library. The order of execution of these modules is that of the entries in the `/etc/pam.conf` file; earlier entries are executed before later ones. As of Linux-PAM v0.60, this control-flag can be defined with one of two syntaxes.

The simpler (and historical) syntax for the control-flag is a single keyword defined to indicate the severity of concern associated with the success or failure of a specific module. There are four such *keywords*: *required*, *requisite*, *sufficient* and *optional*.

The Linux-PAM library interprets these keywords in the following manner:

- *required*: this indicates that the success of the module is required for the module-type facility to succeed. Failure of this module will not be apparent to the user until all of the remaining modules (of the same module-type) have been executed.
- *requisite*: like required, however, in the case that such a module returns a failure, control is directly returned to the application. The return value is that associated with the first required or requisite module to fail. Note, this flag can be used to protect against the possibility of a user getting the opportunity to enter a password over an unsafe medium. It is conceivable that such behavior might inform an attacker of valid accounts on a system. This possibility should be weighed against the not insignificant concerns of exposing a sensitive password in a hostile environment.
- *sufficient*: the success of this module is deemed ‘sufficient’ to satisfy the Linux-PAM library that this module-type has succeeded in its purpose. In the event that no previous required module has failed, no more ‘stacked’ modules of this type are invoked. (Note, in this case subsequent required modules are not invoked.). A failure of this module is not deemed as fatal to satisfying the application that this module-type has succeeded.
- *optional*: as its name suggests, this control-flag marks the module as not being critical to the success or failure of the user’s application for service. In general, Linux-PAM ignores such a module when determining if the module stack will succeed or fail. However, in the absence of any definite successes or failures of previous or subsequent stacked modules this module will determine the nature of the response to the application. One example of this latter case, is when the other modules return something like PAM.IGNORE.

The more elaborate (newer) syntax is much more specific and gives the administrator a great deal of control over how the user is authenticated. This form of the control flag is delimited with square brackets and consists of a series of value=action tokens:

```
[value1=action1 value2=action2 ...]
```

Here, value1 is one of the following return values: success; open_err; symbol_err; service_err; system_err; buf_err; perm_denied; auth_err; cred_insufficient; authinfo_unavail; user_unknown; maxtries; new_authtok_reqd; acct_expired; session_err; cred_unavail; cred_expired; cred_err; no_module_data; conv_err; authtok_err; authtok_recover_err; authtok_lock_busy; authtok_disable_aging; try_again; ignore; abort; authtok_expired; module_unknown; bad_item; and default. The

last of these (default) can be used to set the action for those return values that are not explicitly defined.

The action can be a positive integer or one of the following tokens: ignore; ok; done; bad; die; and reset. A positive integer, J, when specified as the action, can be used to indicate that the next J modules of the current module-type will be skipped. In this way, the administrator can develop a moderately sophisticated stack of modules with a number of different paths of execution. Which path is taken can be determined by the reactions of individual modules.

- *ignore*: when used with a stack of modules, the module's return status will not contribute to the return code the application obtains.
- *bad*: this action indicates that the return code should be thought of as indicative of the module failing. If this module is the first in the stack to fail, its status value will be used for that of the whole stack.
- *die*: equivalent to bad with the side effect of terminating the module stack and PAM immediately returning to the application.
- *ok*: this tells PAM that the administrator thinks this return code should contribute directly to the return code of the full stack of modules. In other words, if the former state of the stack would lead to a return of PAM.SUCCESS, the module's return code will override this value. Note, if the former state of the stack holds some value that is indicative of a module's failure, this 'ok' value will not be used to override that value.
- *done*: equivalent to ok with the side effect of terminating the module stack and PAM immediately returning to the application.
- *reset*: clear all memory of the state of the module stack and start again with the next stacked module.

Each of the four keywords: required; requisite; sufficient; and optional, have an equivalent expression in terms of the [...] syntax. They are as follows:

- required is equivalent to [success=ok new_authtok_reqd=ok ignore=ignore default=bad]
- requisite is equivalent to [success=ok new_authtok_reqd=ok ignore=ignore default=die]
- sufficient is equivalent to [success=done new_authtok_reqd=done default=ignore]
- optional is equivalent to [success=ok new_authtok_reqd=ok default=ignore]

Just to get a feel for the power of this new syntax, here is a taste of what you can do with it. With Linux-PAM-0.63, the notion of client plug-in agents was introduced. This is something that makes it possible for PAM to support machine-machine authentication using the transport protocol inherent to the client/server application. With the [... value=action ...] control syntax, it is possible for an application to be configured to support binary prompts with compliant clients, but to gracefully fall over into an alternative authentication mode for older, legacy, applications.

module-path -

The path-name of the dynamically loadable object file; the pluggable module itself. If the first character of the module path is '/', it is assumed to be a complete path. If this is not the case, the given module path is appended to the default module path: /lib/security (but see the notes above).

The args are a list of tokens that are passed to the module when it is invoked. Much like arguments to a typical Linux shell command. Generally, valid arguments are optional and are specific to any given module. Invalid arguments are ignored by a module, however, when encountering an invalid argument, the module is required to write an error to syslog(3). For a list of generic options see the next section.

Note, if you wish to include spaces in an argument, you should surround that argument with square brackets. For example:

```
squid auth required pam_mysql.so user=passwd_query passwd=mada \  
    db=eminence [query=select user_name from internet_service where \  
    user_name='%u' and password=PASSWORD('%p') and \  
    service='web_proxy']
```

Note, when using this convention, you can include '[' characters inside the string, and if you wish to include a ']' character inside the string that will survive the argument parsing, you should use '\['. In other words:

```
[..[..\]..] --> ..[..]..
```

Any line in (one of) the configuration file(s), that is not formatted correctly, will generally tend (erring on the side of caution) to make the authentication process fail. A corresponding error is written to the system log files with a call to `syslog(3)`.

25.2.2. Example System Configurations

The following is an example `/etc/pam.d/login` configuration file. This example had all options been uncommented is probably not usable as it stacks many conditions before allowing successful completion of the login process. Essentially all conditions can be disabled by commenting them out except the calls to `pam_pwdb.so`.

25.2.2.1. PAM: original login config

```
#!/PAM-1.0  
# The PAM configuration file for the 'login' service  
#  
auth          required    pam_securetty.so  
auth          required    pam_nologin.so  
# auth        required    pam_dialup.so  
# auth        optional    pam_mail.so  
auth          required    pam_pwdb.so shadow md5  
# account     requisite   pam_time.so  
account       required    pam_pwdb.so  
session       required    pam_pwdb.so  
# session     optional    pam_lastlog.so  
# password    required    pam_cracklib.so retry=3  
password      required    pam_pwdb.so shadow md5
```

25.2.2.2. PAM: login using pam_smbpass

PAM allows use of replaceable modules. Those available on a sample system include:
`$/bin/ls /lib/security`

```
pam_access.so    pam_ftp.so        pam_limits.so  
pam_ncp_auth.so  pam_rhosts_auth.so  pam_stress.so
```

pam_cracklib.so	pam_group.so	pam_listfile.so
pam_nologin.so	pam_rootok.so	pam_tally.so
pam_deny.so	pam_issue.so	pam_mail.so
pam_permit.so	pam_securetty.so	pam_time.so
pam_dialup.so	pam_lastlog.so	pam_mkhome.so
pam_pwdb.so	pam_shells.so	pam_unix.so
pam_env.so	pam_ldap.so	pam_motd.so
pam_radius.so	pam_smbpass.so	pam_unix_acct.so
pam_wheel.so	pam_unix_auth.so	pam_unix_passwd.so
pam_userdb.so	pam_warn.so	pam_unix_session.so

The following example for the login program replaces the use of the `pam_pwdb.so` module which uses the system password database (`/etc/passwd`, `/etc/shadow`, `/etc/group`) with the module `pam_smbpass.so` which uses the Samba database which contains the Microsoft MD4 encrypted password hashes. This database is stored in either `/usr/local/samba/private/smbpasswd`, `/etc/samba/smbpasswd`, or in `/etc/samba.d/smbpasswd`, depending on the Samba implementation for your Unix/Linux system. The `pam_smbpass.so` module is provided by Samba version 2.2.1 or later. It can be compiled by specifying the `--with-pam_smbpass` options when running Samba's `configure` script. For more information on the `pam_smbpass` module, see the documentation in the `source/pam_smbpass` directory of the Samba source distribution.

```
#!/PAM-1.0
# The PAM configuration file for the 'login' service
#
auth      required    pam_smbpass.so nodelay
account   required    pam_smbpass.so nodelay
session   required    pam_smbpass.so nodelay
password  required    pam_smbpass.so nodelay
```

The following is the PAM configuration file for a particular Linux system. The default condition uses `pam_pwdb.so`.

```
#!/PAM-1.0
# The PAM configuration file for the 'samba' service
#
auth      required    pam_pwdb.so nullok nodelay shadow audit
account   required    pam_pwdb.so audit nodelay
session   required    pam_pwdb.so nodelay
password  required    pam_pwdb.so shadow md5
```

In the following example the decision has been made to use the `smbpasswd` database even for basic samba authentication. Such a decision could also be made for the `passwd` program and would thus allow the `smbpasswd` passwords to be changed using the `passwd` program.

```
#!/PAM-1.0
# The PAM configuration file for the 'samba' service
#
auth      required    pam_smbpass.so nodelay
```

account	required	pam_pwdb.so	audit	nodelay
session	required	pam_pwdb.so		nodelay
password	required	pam_smbpass.so	nodelay	smbconf=/etc/samba.d/smb.conf

NOTE

PAM allows stacking of authentication mechanisms. It is also possible to pass information obtained within one PAM module through to the next module in the PAM stack. Please refer to the documentation for your particular system implementation for details regarding the specific capabilities of PAM in this environment. Some Linux implementations also provide the `pam_stack.so` module that allows all authentication to be configured in a single central file. The `pam_stack.so` method has some very devoted followers on the basis that it allows for easier administration. As with all issues in life though, every decision makes trade-offs, so you may want examine the PAM documentation for further helpful information.

25.2.3. smb.conf PAM Configuration

There is an option in `smb.conf` called [obey pam restrictions](#). The following is from the on-line help for this option in SWAT;

When Samba-3 is configured to enable PAM support (i.e. `--with-pam`), this parameter will control whether or not Samba should obey PAM's account and session management directives. The default behavior is to use PAM for clear text authentication only and to ignore any account or session management. Note that Samba always ignores PAM for authentication in the case of [encrypt passwords = yes](#). The reason is that PAM modules cannot support the challenge/response authentication mechanism needed in the presence of SMB password encryption.

Default: `obey pam restrictions = no`

25.2.4. Remote CIFS Authentication using winbindd.so

All operating systems depend on the provision of users credentials acceptable to the platform. Unix requires the provision of a user identifier (UID) as well as a group identifier (GID). These are both simple integer type numbers that are obtained from a password backend such as `/etc/passwd`.

Users and groups on a Windows NT server are assigned a relative id (rid) which is unique for the domain when the user or group is created. To convert the Windows NT user or group into a unix user or group, a mapping between rids and unix user and group ids is required. This is one of the jobs that winbind performs.

As winbind users and groups are resolved from a server, user and group ids are allocated from a specified range. This is done on a first come, first served basis, although all existing users and groups will be mapped as soon as a client performs a user or group enumeration command. The allocated unix ids are stored in a database file under the Samba lock directory and will be remembered.

The astute administrator will realize from this that the combination of `pam_smbpass.so`, `winbindd`, and a distributed passwd backend, such as ldap, will allow the estab-

lishment of a centrally managed, distributed user/password database that can also be used by all PAM (eg: Linux) aware programs and applications. This arrangement can have particularly potent advantages compared with the use of Microsoft Active Directory Service (ADS) in so far as reduction of wide area network authentication traffic.

WARNING

The rid to unix id database is the only location where the user and group mappings are stored by winbindd. If this file is deleted or corrupted, there is no way for winbindd to determine which user and group ids correspond to Windows NT user and group rids.

25.2.5. Password Synchronization using pam_smbpass.so

pam_smbpass is a PAM module which can be used on conforming systems to keep the smbpasswd (Samba password) database in sync with the unix password file. PAM (Pluggable Authentication Modules) is an API supported under some Unices, such as Solaris, HPUX and Linux, that provides a generic interface to authentication mechanisms.

This module authenticates a local smbpasswd user database. If you require support for authenticating against a remote SMB server, or if you're concerned about the presence of suid root binaries on your system, it is recommended that you use pam_winbind instead.

Options recognized by this module are as follows:

Table 25.1: Options recognized by pam_smbpass

debug	log more debugging info
audit	like debug, but also logs unknown usernames
use_first_pass	don't prompt the user for passwords; take them from PAM_ items instead
try_first_pass	try to get the password from a previous PAM module, fall back to prompting the user
use_authtok	like try_first_pass, but *fail* if the new PAM_AUTH Tok has not been previously set. (intended for stacking password modules only)
not_set_pass	don't make passwords used by this module available to other modules.
nodelay	don't insert ~1 second delays on authentication failure.
nullok	null passwords are allowed.
nonnull	null passwords are not allowed. Used to override the Samba configuration.
migrate	only meaningful in an "auth" context; used to update smbpasswd file with a password used for successful authentication.
smbconf=file	specify an alternate path to the smb.conf file.

Thanks go to the following people:

[Andrew Morgan](#), for providing the Linux-PAM framework, without which none of this would have happened

[Christian Gafton](#) and Andrew Morgan again, for the pam_pwd module upon which pam_smbpass was originally based

[Luke Leighton](#) for being receptive to the idea, and for the occasional good-natured complaint about the project's status that keep me working on it :)

The following are examples of the use of pam_smbpass.so in the format of Linux /etc/pam.d/ files structure. Those wishing to implement this tool on other platforms will need to adapt this appropriately.

25.2.5.1. Password Synchronisation Configuration

A sample PAM configuration that shows the use of pam_smbpass to make sure private/smbpasswd is kept in sync when /etc/passwd (/etc/shadow) is changed. Useful when an expired password might be changed by an application (such as ssh).

```
#!/PAM-1.0
# password-sync
#
auth      requisite    pam_nologin.so
auth      required     pam_unix.so
account   required     pam_unix.so
password  requisite    pam_cracklib.so retry=3
password  requisite    pam_unix.so shadow md5 use_authtok try_first_pass
password  required     pam_smbpass.so nullok use_authtok try_first_pass
session   required     pam_unix.so
```

25.2.5.2. Password Migration Configuration

A sample PAM configuration that shows the use of pam_smbpass to migrate from plaintext to encrypted passwords for Samba. Unlike other methods, this can be used for users who have never connected to Samba shares: password migration takes place when users ftp in, login using ssh, pop their mail, etc.

```
#!/PAM-1.0
# password-migration
#
auth      requisite    pam_nologin.so
# pam_smbpass is called IF pam_unix succeeds.
auth      requisite    pam_unix.so
auth      optional     pam_smbpass.so migrate
account   required     pam_unix.so
password  requisite    pam_cracklib.so retry=3
password  requisite    pam_unix.so shadow md5 use_authtok try_first_pass
password  optional     pam_smbpass.so nullok use_authtok try_first_pass
session   required     pam_unix.so
```

25.2.5.3. Mature Password Configuration

A sample PAM configuration for a 'mature' smbpasswd installation. `private/smbpasswd` is fully populated, and we consider it an error if the `smbpasswd` doesn't exist or doesn't match the Unix password.

```
#!/PAM-1.0
# password-mature
#
auth      requisite    pam_nologin.so
auth      required    pam_unix.so
account   required    pam_unix.so
password  requisite    pam_cracklib.so retry=3
password  requisite    pam_unix.so shadow md5 use_authtok try_first_pass
password  required    pam_smbpass.so use_authtok use_first_pass
session   required    pam_unix.so
```

25.2.5.4. Kerberos Password Integration Configuration

A sample PAM configuration that shows `pam_smbpass` used together with `pam_krb5`. This could be useful on a Samba PDC that is also a member of a Kerberos realm.

```
#!/PAM-1.0
# kdc-pdc
#
auth      requisite    pam_nologin.so
auth      requisite    pam_krb5.so
auth      optional    pam_smbpass.so migrate
account   required    pam_krb5.so
password  requisite    pam_cracklib.so retry=3
password  optional    pam_smbpass.so nullok use_authtok try_first_pass
password  required    pam_krb5.so use_authtok try_first_pass
session   required    pam_krb5.so
```

25.3. Common Errors

PAM can be a very fickle and sensitive to configuration glitches. Here we look at a few cases from the Samba mailing list.

25.3.1. `pam_winbind` problem

I have the following PAM configuration:

```
auth required /lib/security/pam_securetty.so
auth sufficient /lib/security/pam_winbind.so
auth sufficient /lib/security/pam_unix.so use_first_pass nullok
auth required /lib/security/pam_stack.so service=system-auth
auth required /lib/security/pam_nologin.so
account required /lib/security/pam_stack.so service=system-auth
account required /lib/security/pam_winbind.so
```

```
password required /lib/security/pam_stack.so service=system-auth
```

When I open a new console with [ctrl][alt][F1], then I cant log in with my user "pitie". I've tried with user "scienceu+pitie" also.

Answer: The problem may lie with your inclusion of pam_stack.so service=system-auth. That file often contains a lot of stuff that may duplicate what you're already doing. Try commenting out the pam_stack lines for auth and account and see if things work. If they do, look at /etc/pam.d/system-auth and copy only what you need from it into your /etc/pam.d/login file. Alternatively, if you want all services to use winbind, you can put the winbind-specific stuff in /etc/pam.d/system-auth.

26. Integrating MS Windows networks with Samba

This section deals with NetBIOS over TCP/IP name to IP address resolution. If your MS Windows clients are NOT configured to use NetBIOS over TCP/IP then this section does not apply to your installation. If your installation involves use of NetBIOS over TCP/IP then this section may help you to resolve networking problems.

NOTE



NetBIOS over TCP/IP has nothing to do with NetBEUI. NetBEUI is NetBIOS over Logical Link Control (LLC). On modern networks it is highly advised to NOT run NetBEUI at all. Note also that there is NO such thing as NetBEUI over TCP/IP - the existence of such a protocol is a complete and utter mis-apprehension.

26.1. Features and Benefits

Many MS Windows network administrators have never been exposed to basic TCP/IP networking as it is implemented in a Unix/Linux operating system. Likewise, many Unix and Linux administrators have not been exposed to the intricacies of MS Windows TCP/IP based networking (and may have no desire to be either).

This chapter gives a short introduction to the basics of how a name can be resolved to it's IP address for each operating system environment.

26.2. Background Information

Since the introduction of MS Windows 2000 it is possible to run MS Windows networking without the use of NetBIOS over TCP/IP. NetBIOS over TCP/IP uses UDP port 137 for NetBIOS name resolution and uses TCP port 139 for NetBIOS session services. When NetBIOS over TCP/IP is disabled on MS Windows 2000 and later clients then only TCP port 445 will be used and UDP port 137 and TCP port 139 will not.

NOTE



When using Windows 2000 or later clients, if NetBIOS over TCP/IP is NOT disabled, then the client will use UDP port 137 (NetBIOS Name Service, also known as the Windows Internet Name Service or WINS), TCP port 139 AND TCP port 445 (for actual file and print traffic).

When NetBIOS over TCP/IP is disabled the use of DNS is essential. Most installations that disable NetBIOS over TCP/IP today use MS Active Directory Service (ADS). ADS requires Dynamic DNS with Service Resource Records (SRV RR) and with Incremental Zone Transfers (IXFR). Use of DHCP with ADS is recommended as a further means of maintaining central control over client workstation network configuration.

26.3. Name Resolution in a pure Unix/Linux world

The key configuration files covered in this section are:

- `/etc/hosts`
- `/etc/resolv.conf`
- `/etc/host.conf`
- `/etc/nsswitch.conf`

26.3.1. `/etc/hosts`

Contains a static list of IP Addresses and names. eg:

```
127.0.0.1 localhost localhost.localdomain
192.168.1.1 bigbox.caldera.com bigbox alias4box
```

The purpose of `/etc/hosts` is to provide a name resolution mechanism so that users do not need to remember IP addresses.

Network packets that are sent over the physical network transport layer communicate not via IP addresses but rather using the Media Access Control address, or MAC address. IP Addresses are currently 32 bits in length and are typically presented as four (4) decimal numbers that are separated by a dot (or period). eg: 168.192.1.1.

MAC Addresses use 48 bits (or 6 bytes) and are typically represented as two digit hexadecimal numbers separated by colons. eg: 40:8e:0a:12:34:56

Every network interface must have an MAC address. Associated with a MAC address there may be one or more IP addresses. There is NO relationship between an IP address and a MAC address, all such assignments are arbitrary or discretionary in nature. At the most basic level all network communications takes place using MAC addressing. Since MAC addresses must be globally unique, and generally remains fixed for any particular interface, the assignment of an IP address makes sense from a network management perspective. More than one IP address can be assigned per MAC address. One address must be the primary IP address, this is the address that will be returned in the ARP reply.

When a user or a process wants to communicate with another machine the protocol implementation ensures that the "machine name" or "host name" is resolved to an IP address in a manner that is controlled by the TCP/IP configuration control files. The file `/etc/hosts` is one such file.

When the IP address of the destination interface has been determined a protocol called ARP/RARP is used to identify the MAC address of the target interface. ARP stands for Address Resolution Protocol, and is a broadcast oriented method that uses UDP (User Datagram Protocol) to send a request to all interfaces on the local network segment using the all 1's MAC address. Network interfaces are programmed to respond to two MAC addresses only; their own unique address and the address ff:ff:ff:ff:ff:ff. The reply packet from an ARP request will contain the MAC address and the primary IP address for each interface.

The `/etc/hosts` file is foundational to all Unix/Linux TCP/IP installations and as a minimum will contain the localhost and local network interface IP addresses and the primary names by which they are known within the local machine. This file helps to prime the pump so that a basic level of name resolution can exist before any other method of name resolution becomes available.

26.3.2. `/etc/resolv.conf`

This file tells the name resolution libraries:

- The name of the domain to which the machine belongs
- The name(s) of any domains that should be automatically searched when trying to resolve unqualified host names to their IP address
- The name or IP address of available Domain Name Servers that may be asked to perform name to address translation lookups

26.3.3. `/etc/host.conf`

`/etc/host.conf` is the primary means by which the setting in `/etc/resolv.conf` may be affected. It is a critical configuration file. This file controls the order by which name resolution may proceed. The typical structure is:

```
order hosts,bind
multi on
```

then both addresses should be returned. Please refer to the man page for `host.conf` for further details.

26.3.4. `/etc/nsswitch.conf`

This file controls the actual name resolution targets. The file typically has resolver object specifications as follows:

```
# /etc/nsswitch.conf
#
# Name Service Switch configuration file.
#

passwd:    compat
# Alternative entries for password authentication are:
# passwd:  compat files nis ldap winbind
shadow:    compat
group:     compat

hosts:     files nis dns
# Alternative entries for host name resolution are:
# hosts:   files dns nis nis+ hesoid db compat ldap wins
networks:  nis files dns

ethers:    nis files
protocols: nis files
rpc:       nis files
services:  nis files
```

Of course, each of these mechanisms requires that the appropriate facilities and/or services are correctly configured.

It should be noted that unless a network request/message must be sent, TCP/IP networks are silent. All TCP/IP communications assumes a principal of speaking only when necessary.

Starting with version 2.2.0 samba has Linux support for extensions to the name service switch infrastructure so that linux clients will be able to obtain resolution of MS Windows NetBIOS names to IP Addresses. To gain this functionality Samba needs to be compiled with appropriate arguments to the make command (ie: make nsswitch/libnss_wins.so). The resulting library should then be installed in the `/lib` directory and the "wins" parameter needs to be added to the "hosts:" line in the `/etc/nsswitch.conf` file. At this point it will be possible to ping any MS Windows machine by it's NetBIOS machine name, so long as that machine is within the workgroup to which both the samba machine and the MS Windows machine belong.

26.4. Name resolution as used within MS Windows networking

MS Windows networking is predicated about the name each machine is given. This name is known variously (and inconsistently) as the "computer name", "machine name", "networking name", "netbios name", "SMB name". All terms mean the same thing with the exception of "netbios name" which can apply also to the name of the workgroup or the domain name. The terms "workgroup" and "domain" are really just a simply name with which the machine is associated. All NetBIOS names are exactly 16 characters in length. The 16th character is reserved. It is used to store a one byte value that indicates service level information for the NetBIOS name that is registered. A NetBIOS machine name is therefore registered for each service type that is provided by the client/server.

The following are typical NetBIOS name/service type registrations:

Unique NetBIOS Names:

```
MACHINENAME<00> = Server Service is running on MACHINENAME
MACHINENAME<03> = Generic Machine Name (NetBIOS name)
MACHINENAME<20> = LanMan Server service is running on MACHINENAME
WORKGROUP<1b> = Domain Master Browser
```

Group Names:

```
WORKGROUP<03> = Generic Name registered by all members of WORKGROUP
WORKGROUP<1c> = Domain Controllers / Netlogon Servers
WORKGROUP<1d> = Local Master Browsers
WORKGROUP<1e> = Internet Name Resolvers
```

It should be noted that all NetBIOS machines register their own names as per the above. This is in vast contrast to TCP/IP installations where traditionally the system administrator will determine in the `/etc/hosts` or in the DNS database what names are associated with each IP address.

One further point of clarification should be noted, the `/etc/hosts` file and the DNS records do not provide the NetBIOS name type information that MS Windows clients depend on to locate the type of service that may be needed. An example of this is what happens when an MS Windows client wants to locate a domain logon server. It finds this service and the IP address of a server that provides it

by performing a lookup (via a NetBIOS broadcast) for enumeration of all machines that have registered the name type *<1c>. A logon request is then sent to each IP address that is returned in the enumerated list of IP addresses. Which ever machine first replies then ends up providing the logon services.

The name "workgroup" or "domain" really can be confusing since these have the added significance of indicating what is the security architecture of the MS Windows network. The term "workgroup" indicates that the primary nature of the network environment is that of a peer-to-peer design. In a WORKGROUP all machines are responsible for their own security, and generally such security is limited to use of just a password (known as SHARE MODE security). In most situations with peer-to-peer networking the users who control their own machines will simply opt to have no security at all. It is possible to have USER MODE security in a WORKGROUP environment, thus requiring use of a user name and a matching password.

MS Windows networking is thus predetermined to use machine names for all local and remote machine message passing. The protocol used is called Server Message Block (SMB) and this is implemented using the NetBIOS protocol (Network Basic Input Output System). NetBIOS can be encapsulated using LLC (Logical Link Control) protocol - in which case the resulting protocol is called NetBEUI (Network Basic Extended User Interface). NetBIOS can also be run over IPX (Internetworking Packet Exchange) protocol as used by Novell NetWare, and it can be run over TCP/IP protocols - in which case the resulting protocol is called NBT or NetBT, the NetBIOS over TCP/IP.

MS Windows machines use a complex array of name resolution mechanisms. Since we are primarily concerned with TCP/IP this demonstration is limited to this area.

26.4.1. The NetBIOS Name Cache

All MS Windows machines employ an in memory buffer in which is stored the NetBIOS names and IP addresses for all external machines that that machine has communicated with over the past 10-15 minutes. It is more efficient to obtain an IP address for a machine from the local cache than it is to go through all the configured name resolution mechanisms.

If a machine whose name is in the local name cache has been shut down before the name had been expired and flushed from the cache, then an attempt to exchange a message with that machine will be subject to time-out delays. i.e.: Its name is in the cache, so a name resolution lookup will succeed, but the machine can not respond. This can be frustrating for users - but it is a characteristic of the protocol.

The MS Windows utility that allows examination of the NetBIOS name cache is called "nbtstat". The Samba equivalent of this is called **nmblookup**.

26.4.2. The LMHOSTS file

This file is usually located in MS Windows NT 4.0 or 2000 in C:\WINNT\SYSTEM32\DRIVERS\ETC and contains the IP Address and the machine name in matched pairs. The LMHOSTS file performs NetBIOS name to IP address mapping.

It typically looks like:

```
# Copyright (c) 1998 Microsoft Corp.
#
# This is a sample LMHOSTS file used by the Microsoft Wins Client (NetBIOS
# over TCP/IP) stack for Windows98
#
# This file contains the mappings of IP addresses to NT computernames
```

```
# (NetBIOS) names. Each entry should be kept on an individual line.
# The IP address should be placed in the first column followed by the
# corresponding computername. The address and the computername
# should be separated by at least one space or tab. The "#" character
# is generally used to denote the start of a comment (see the exceptions
# below).
#
# This file is compatible with Microsoft LAN Manager 2.x TCP/IP lmhosts
# files and offers the following extensions:
#
#     #PRE
#     #DOM:<domain>
#     #INCLUDE <filename>
#     #BEGIN_ALTERNATE
#     #END_ALTERNATE
#     \Oxnn (non-printing character support)
#
# Following any entry in the file with the characters "#PRE" will cause
# the entry to be preloaded into the name cache. By default, entries are
# not preloaded, but are parsed only after dynamic name resolution fails.
#
# Following an entry with the "#DOM:<domain>" tag will associate the
# entry with the domain specified by <domain>. This affects how the
# browser and logon services behave in TCP/IP environments. To preload
# the host name associated with #DOM entry, it is necessary to also add a
# #PRE to the line. The <domain> is always preloaded although it will not
# be shown when the name cache is viewed.
#
# Specifying "#INCLUDE <filename>" will force the RFC NetBIOS (NBT)
# software to seek the specified <filename> and parse it as if it were
# local. <filename> is generally a UNC-based name, allowing a
# centralized lmhosts file to be maintained on a server.
# It is ALWAYS necessary to provide a mapping for the IP address of the
# server prior to the #INCLUDE. This mapping must use the #PRE directive.
# In addition the share "public" in the example below must be in the
# LanManServer list of "NullSessionShares" in order for client machines to
# be able to read the lmhosts file successfully. This key is under
# \machine\system\currentcontrolset\services\lanmanserver\parameters\nullsessions
# in the registry. Simply add "public" to the list found there.
#
# The #BEGIN_ and #END_ALTERNATE keywords allow multiple #INCLUDE
# statements to be grouped together. Any single successful include
# will cause the group to succeed.
#
# Finally, non-printing characters can be embedded in mappings by
# first surrounding the NetBIOS name in quotations, then using the
# \Oxnn notation to specify a hex value for a non-printing character.
#
# The following example illustrates all of these extensions:
#
# 102.54.94.97      rhino          #PRE #DOM:networking  #net group's DC
# 102.54.94.102    "appname  \Ox14"      #special app server
```

```
# 102.54.94.123    popular          #PRE          #source server
# 102.54.94.117    localsrv         #PRE          #needed for the include
#
# #BEGIN_ALTERNATE
# #INCLUDE \\localsrv\public\lmhosts
# #INCLUDE \\rhino\public\lmhosts
# #END_ALTERNATE
#
# In the above example, the "appname" server contains a special
# character in its name, the "popular" and "localsrv" server names are
# preloaded, and the "rhino" server name is specified so it can be used
# to later #INCLUDE a centrally maintained lmhosts file if the "localsrv"
# system is unavailable.
#
# Note that the whole file is parsed including comments on each lookup,
# so keeping the number of comments to a minimum will improve performance.
# Therefore it is not advisable to simply add lmhosts file entries onto the
# end of this file.
```

26.4.3. HOSTS file

This file is usually located in MS Windows NT 4.0 or 2000 in `C:\WINNT\SYSTEM32\DRIVERS\ETC` and contains the IP Address and the IP hostname in matched pairs. It can be used by the name resolution infrastructure in MS Windows, depending on how the TCP/IP environment is configured. This file is in every way the equivalent of the Unix/Linux `/etc/hosts` file.

26.4.4. DNS Lookup

This capability is configured in the TCP/IP setup area in the network configuration facility. If enabled an elaborate name resolution sequence is followed the precise nature of which is dependant on what the NetBIOS Node Type parameter is configured to. A Node Type of 0 means use NetBIOS broadcast (over UDP broadcast) is first used if the name that is the subject of a name lookup is not found in the NetBIOS name cache. If that fails then DNS, HOSTS and LMHOSTS are checked. If set to Node Type 8, then a NetBIOS Unicast (over UDP Unicast) is sent to the WINS Server to obtain a lookup before DNS, HOSTS, LMHOSTS, or broadcast lookup is used.

26.4.5. WINS Lookup

A WINS (Windows Internet Name Server) service is the equivalent of the rfc1001/1002 specified NBNS (NetBIOS Name Server). A WINS server stores the names and IP addresses that are registered by a Windows client if the TCP/IP setup has been given at least one WINS Server IP Address.

To configure Samba to be a WINS server the following parameter needs to be added to the `smb.conf` file:

```
wins support = Yes
```

To configure Samba to use a WINS server the following parameters are needed in the `smb.conf` file:

```
wins support = No
wins server = xxx.xxx.xxx.xxx
```

where xxx.xxx.xxx.xxx is the IP address of the WINS server.

26.5. Common Errors

TCP/IP network configuration problems find every network administrator sooner or later. The cause can be anything from keyboard mishaps, forgetfulness, simple mistakes, and carelessness. Of course, no one is every deliberately careless!

26.5.1. My Boomerang Won't Come Back

Well, the real complaint said, "I can ping my samba server from Windows, but I can not ping my Windows machine from the samba server."

The Windows machine was at IP Address 192.168.1.2 with netmask 255.255.255.0, the Samba server (Linux) was at IP Address 192.168.1.130 with netmask 255.255.255.128. The machines were on a local network with no external connections.

Due to inconsistent netmasks, the Windows machine was on network 192.168.1.0/24, while the Samba server was on network 192.168.1.128/25 - logically a different network.

26.5.2. Very Slow Network Connections

A common causes of slow network response includes:

- Client is configured to use DNS and DNS server is down
- Client is configured to use remote DNS server, but remote connection is down
- Client is configured to use a WINS server, but there is no WINS server
- Client is NOT configured to use a WINS server, but there is a WINS server
- Firewall is filtering our DNS or WINS traffic

26.5.3. Samba server name change problem

The name of the samba server was changed, samba was restarted, samba server can not be pinged by new name from MS Windows NT4 Workstation, but it does still respond to ping using the old name. Why?

From this description three (3) things are rather obvious:

- WINS is NOT in use, only broadcast based name resolution is used
- The samba server was renamed and restarted within the last 10-15 minutes
- The old samba server name is still in the NetBIOS name cache on the MS Windows NT4 Workstation

To find what names are present in the NetBIOS name cache on the MS Windows NT4 machine, open a cmd shell, then:

```
C:\temp\>nbtstat -n
```

NetBIOS Local Name Table

Name	Type	Status
SLACK	<03> UNIQUE	Registered

```

ADMINISTRATOR <03> UNIQUE Registered
SLACK <00> UNIQUE Registered
SARDON <00> GROUP Registered
SLACK <20> UNIQUE Registered
SLACK <1F> UNIQUE Registered

```

```
C:\Temp\>nbtstat -c
```

NetBIOS Remote Cache Name Table

Name	Type	Host Address	Life [sec]
FRODO	<20> UNIQUE	192.168.1.1	240

```
C:\Temp\>
```

In the above example, FRODO is the Samba server and SLACK is the MS Windows NT4 Workstation. The first listing shows the contents of the Local Name Table (ie: Identity information on the MS Windows workstation), the second shows the NetBIOS name in the NetBIOS name cache. The name cache contains the remote machines known to this workstation.

27. Unicode/Charsets

27.1. Features and Benefits

Every industry eventually matures. One of the great areas of maturation is in the focus that has been given over the past decade to make it possible for anyone anywhere to use a computer. It has not always been that way, in fact, not so long ago it was common for software to be written for exclusive use in the country of origin.

Of all the effort that has been brought to bear on providing native language support for all computer users, the efforts of the Openi18n organisation is deserving of special mention. For more information about Openi18n please refer to: `Xrefld[?http://www.openi18n.org/?]`.

Samba-2.x supported a single locale through a mechanism called *codepages*. Samba-3 is destined to become a truly trans-global file and printer sharing platform.

27.2. What are charsets and unicode?

Computers communicate in numbers. In texts, each number will be translated to a corresponding letter. The meaning that will be assigned to a certain number depends on the *character set(charset)* that is used. A charset can be seen as a table that is used to translate numbers to letters. Not all computers use the same charset (there are charsets with German umlauts, Japanese characters, etc). Usually a charset contains 256 characters, which means that storing a character with it takes exactly one byte.

There are also charsets that support even more characters, but those need twice(or even more) as much storage space. These charsets can contain $256 * 256 = 65536$ characters, which is more than all possible characters one could think of. They are called multibyte charsets (because they use more than one byte to store one character).

A standardised multibyte charset is unicode, info is available at www.unicode.org. A big advantage of using a multibyte charset is that you only need one; no need to make sure two computers use the same charset when they are communicating.

Old windows clients used to use single-byte charsets, named 'codepages' by microsoft. However, there is no support for negotiating the charset to be used in the smb protocol. Thus, you have to make sure you are using the same charset when talking to an old client. Newer clients (Windows NT, 2K, XP) talk unicode over the wire.

27.3. Samba and charsets

As of samba 3.0, samba can (and will) talk unicode over the wire. Internally, samba knows of three kinds of character sets:

unix charset This is the charset used internally by your operating system. The default is ASCII, which is fine for most systems.

display charset This is the charset samba will use to print messages on your screen. It should generally be the same as the **unix charset**.

dos charset This is the charset samba uses when communicating with DOS and Windows 9x clients. It will talk unicode to all newer clients. The default depends on the charsets you have installed on your system. Run **testparm -v** — **grep "dos charset"** to see what the default is on your system.

27.4. Conversion from old names

Because previous samba versions did not do any charset conversion, characters in filenames are usually not correct in the unix charset but only for the local charset used by the DOS/Windows clients.

The following script from Steve Langasek converts all filenames from CP850 to the iso8859-15 charset.

```
#find /path/to/share -type f -exec bash -c 'CP="{ }"; ISO='echo -n "$CP" —  
iconv -f cp850 \-t iso8859-15'; if [ "$CP" != "$ISO" ]; then mv "$CP" "$ISO"; fi \;
```

27.5. Japanese charsets

Samba doesn't work correctly with Japanese charsets yet. Here are points of attention when setting it up:

- You should set mangling method = hash
- There are various iconv() implementations around and not all of them work equally well. glibc2's iconv() has a critical problem in CP932. libiconv-1.8 works with CP932 but still has some problems and does not work with EUC-JP.
- You should set dos charset = CP932, not Shift_JIS, SJIS...
- Currently only unix charset = CP932 will work (but still has some problems...) because of iconv() issues. unix charset = EUC-JP doesn't work well because of iconv() issues.
- Currently Samba 3.0 does not support unix charset = UTF8-MAC/CAP/HEX/JIS*

More information (in Japanese) is available at: <http://www.atmarkit.co.jp/flinux/special/samba3/samba3a.html>.

28. Samba Backup Techniques

28.1. Note

This chapter did not make it into this release. It is planned for the published release of this document. If you have something to contribute for this section please email it to [XrefId\[?jht@samba.org?\]/](mailto:XrefId[?jht@samba.org?]/)

28.2. Features and Benefits

We need feedback from people who are backing up samba servers. We would like to know what software tools you are using to backup your samba server/s.

In particular, if you have any success and / or failure stories you could share with other users this would be appreciated.

29. High Availability Options

29.1. Note

This chapter did not make it into this release. It is planned for the published release of this document.

Part IV.

Migration and Updating

30. Upgrading from Samba-2.x to Samba-3.0.0

30.1. Charsets

You might experience problems with special characters when communicating with old DOS clients. Codepage support has changed in samba 3.0. Read the chapter [Unicode support](#) for details.

30.2. Obsolete configuration options

In 3.0, the following configuration options have been removed.

- printer driver (replaced by new driver procedures)
- printer driver file (replaced by new driver procedures)
- printer driver location (replaced by new driver procedures)
- use rhosts
- postscript
- client code page (replaced by dos charset)
- vfs path
- vfs options

30.3. Password Backend

Effective with the release of samba-3 it is now imperative that the password backend be correctly defined in smb.conf.

Those migrating from samba-2.x with plaintext password support need the following: *passdb backend = guest*.

Those migrating from samba-2.x with encrypted password support should add to smb.conf *passdb backend = smbpasswd, guest*.

LDAP using Samba-2.x systems can continue to operate with the following entry *passdb backend = ldapsam_compat, guest*.

31. Migration from NT4 PDC to Samba-3 PDC

This is a rough guide to assist those wishing to migrate from NT4 domain control to Samba-3 based domain control.

31.1. Planning and Getting Started

In the IT world there is often a saying that all problems are encountered because of poor planning. The corollary to this saying is that not all problems can be anticipated and planned for. Then again, good planning will anticipate most show stopper type situations.

Those wishing to migrate from MS Windows NT4 domain control to a Samba-3 domain control environment would do well to develop a detailed migration plan. So here are a few pointers to help migration get under way.

31.1.1. Objectives

The key objective for most organisations will be to make the migration from MS Windows NT4 to Samba-3 domain control as painless as possible. One of the challenges you may experience in your migration process may well be one of convincing management that the new environment should remain in place. Many who have introduced open source technologies have experienced pressure to return to a Microsoft based platform solution at the first sign of trouble.

It is strongly advised that before attempting a migration to a Samba-3 controlled network that every possible effort be made to gain all-round commitment to the change. Firstly, you should know precisely *why* the change is important for the organisation. Possible motivations to make a change include:

- Improve network manageability
- Obtain better user level functionality
- Reduce network operating costs
- Reduce exposure caused by Microsoft withdrawal of NT4 support
- Avoid MS License 6 implications
- Reduce organisation's dependency on Microsoft

It is vital that it be well recognised that Samba-3 is NOT MS Windows NT4. Samba-3 offers an alternative solution that is both different from MS Windows NT4 and that offers some advantages compared with it. It should also be recognised that Samba-3 lacks many of the features that Microsoft has promoted as core values in migration from MS Windows NT4 to MS Windows 2000 and beyond (with or without Active Directory services).

What are the features that Samba-3 can NOT provide?

- Active Directory Server
- Group Policy Objects (in Active Directory)
- Machine Policy objects
- Logon Scripts in Active Directory
- Software Application and Access Controls in Active Directory

The features that Samba-3 DOES provide and that may be of compelling interest to your site includes:

- Lower Cost of Ownership
- Global availability of support with no strings attached
- Dynamic SMB Servers (ie:Can run more than one server per Unix/Linux system)
- Creation of on-the-fly logon scripts
- Creation of on-the-fly Policy Files
- Greater Stability, Reliability, Performance and Availability
- Manageability via an ssh connection
- Flexible choices of back-end authentication technologies (tdbsam, ldapsam, mysqsam)
- Ability to implement a full single-signon architecture
- Ability to distribute authentication systems for absolute minimum wide area network bandwidth demand

Before migrating a network from MS Windows NT4 to Samba-3 it is vital that all necessary factors are considered. Users should be educated about changes they may experience so that the change will be a welcome one and not become an obstacle to the work they need to do. The following are some of the factors that will go into a successful migration:

31.1.1.1. Domain Layout

Samba-3 can be configured as a domain controller, a back-up domain controller (probably best called a secondary controller), a domain member, or as a stand-alone server. The Windows network security domain context should be sized and scoped before implementation. Particular attention needs to be paid to the location of the primary domain controller (PDC) as well as backup controllers (BDCs). It should be noted that one way in which Samba-3 differs from Microsoft technology is that if one chooses to use an LDAP authentication backend then the same database can be used by several different domains. This means that in a complex organisation there can be a single LDAP database, that itself can be distributed, that can simultaneously serve multiple domains (that can also be widely distributed).

It is recommended that from a design perspective, the number of users per server, as well as the number of servers, per domain should be scaled according to needs and should also consider server capacity and network bandwidth.

A physical network segment may house several domains, each of which may span multiple network segments. Where domains span routed network segments it is most advisable to consider and test the performance implications of the design and layout of a network. A Centrally located domain controller that is being designed to serve multiple routed network segments may result in severe performance problems if the response time (eg: ping timing) between the remote segment and the PDC is more than 100 ms. In situations where the delay is too long it is highly recommended to locate a backup controller (BDC) to serve as the local authentication and access control server.

31.1.1.2. Server Share and Directory Layout

There are few cardinal rules to effective network design that can be broken with impunity. The most important rule of effective network management is that simplicity is king in every well controlled network. Every part of the infrastructure must be managed, the more complex it is, the greater will be the demand of keeping systems secure and functional.

The nature of the data that must be stored needs to be born in mind when deciding how many shares must be created. The physical disk space layout should also be taken into account when designing where share points will be created. Keep in mind that all data needs to be backed up, thus the simpler the disk layout the easier it will be to keep track of what must be backed up to tape or other off-line storage medium. Always plan and implement for minimum maintenance. Leave nothing to chance in your design, above all, do not leave backups to chance: Backup and test, validate every backup, create a disaster recovery plan and prove that it works.

Users should be grouped according to data access control needs. File and directory access is best controlled via group permissions and the use of the "sticky bit" on group controlled directories may substantially avoid file access complaints from samba share users.

Many network administrators who are new to the game will attempt to use elaborate techniques to set access controls, on files, directories, shares, as well as in share definitions. There is the ever present danger that that administrator's successor will not understand the complex mess that has been inherited. Remember, apparent job security through complex design and implementation may ultimately cause loss of operations and downtime to users as the new administrator learns to untangle your web. Keep access controls simple and effective and make sure that users will never be interrupted by the stupidity of complexity.

31.1.1.3. Logon Scripts

Please refer to the section of this document on Advanced Network Administration for information regarding the network logon script options for Samba-3. Logon scripts can help to ensure that all users gain share and printer connections they need.

Logon scripts can be created on-the-fly so that all commands executed are specific to the rights and privileges granted to the user. The preferred controls should be affected through group membership so that group information can be used to custom create a logon script using the root preexec parameters to the NETLOGON share.

Some sites prefer to use a tool such as **kixstart** to establish a controlled user environment. In any case you may wish to do a google search for logon script process controls. In particular, you may wish to explore the use of the Microsoft knowledgebase article KB189105 that deals with how to add printers without user intervention via the logon script process.

31.1.1.4. Profile Migration/Creation

User and Group Profiles may be migrated using the tools described in the section titled Desktop Profile Management.

Profiles may also be managed using the Samba-3 tool **profiles**. This tool allows the MS Windows NT style security identifiers (SIDs) that are stored inside the profile NTuser.DAT file to be changed to the SID of the Samba-3 domain.

31.1.1.5. User and Group Accounts

It is possible to migrate all account settings from an MS Windows NT4 domain to Samba-3. Before attempting to migrate user and group accounts it is **STRONGLY** advised to create in Samba-3 the groups that are present on the MS Windows NT4 domain *AND* to connect these to suitable Unix/Linux groups. Following this simple advice will mean that all user and group attributes should migrate painlessly.

31.1.2. Steps In Migration Process

The approximate migration process is described below.

- You will have an NT4 PDC that has the users, groups, policies and profiles to be migrated
- Samba-3 set up as a DC with netlogon share, profile share, etc.

THE ACCOUNT MIGRATION PROCESS

1. Create a BDC account for the samba server using NT Server Manager
 - a) Samba must NOT be running
2. `rpcclient NT4PDC -U Administrator%passwd`
 - a) `lsaquery`
 - b) Note the SID returned
3. `net getsid -S NT4PDC -w DOMNAME -U Administrator%passwd`
 - a) Note the SID
4. `net getlocalsid`
 - a) Note the SID, now check that all three SIDS reported are the same!
5. `net rpc join -S NT4PDC -w DOMNAME -U Administrator%passwd`
6. `net rpc vampire -S NT4PDC -U administrator%passwd`
7. `pdbedit -L`
 - a) Note - did the users migrate?
8. `initGrps.sh DOMNAME`
9. `net groupmap list`
 - a) Now check that all groups are recognised
10. `net rpc campire -S NT4PDC -U administrator%passwd`
11. `pdbedit -Lv`
 - a) Note - check that all group membership has been migrated

Now it is time to migrate all the profiles, then migrate all policy files. More later.

31.2. Migration Options

Based on feedback from many sites as well as from actual installation and maintenance experience sites that wish to migrate from MS Windows NT4 Domain Control to a Samba based solution fit into three basic categories.

Table 31.1: The 3 Major Site Types

Number of Users	Description
< 50	Want simple conversion with NO pain
50 - 250	Want new features, can manage some in-house complexity
> 250	Solution/Implementation MUST scale well, complex needs. Cross departmental decision process. Local expertise in most areas

31.2.1. Planning for Success

There are three basic choices for sites that intend to migrate from MS Windows NT4 to Samba-3.

- Simple Conversion (total replacement)
- Upgraded Conversion (could be one of integration)
- Complete Redesign (completely new solution)

No matter what choice you make, the following rules will minimise down-stream problems:

- Take sufficient time
- Avoid Panic
- Test ALL assumptions
- Test full roll-out program, including workstation deployment

Table 31.2: Nature of the Conversion Choices

Simple	Upgraded	Redesign
Make use of minimal OS specific features	Translate NT4 features to new host OS features	Decide:
Suck all accounts from NT4 into Samba-3	Copy and improve:	Authentication Regime (database location and access)
Make least number of operational changes	Make progressive improvements	Desktop Management Methods
Take least amount of time to migrate	Minimise user impact	Better Control of Desktops / Users
Live versus Isolated Conversion	Maximise functionality	Identify Needs for: Manageability, Scalability, Security, Availability
Integrate Samba-3 then migrate while users are active, then Change of control (ie: swap out)	Take advantage of lower maintenance opportunity	

31.2.2. Samba Implementation Choices

Authentication database back end

Winbind (external Samba or NT4/200x server)

Can use pam_mkhome.so to auto-create home dirs

External server could use Active Directory or NT4 Domain

Database type

smbpasswd, tdbsam, ldapsam, MySQLsam

Access Control Points

On the Share itself (Use NT4 Server Manager)

On the file system

Unix permissions on files and directories

Posix ACLs enablement in file system?

Through Samba share parameters

Not recommended - except as only resort

Policies (migrate or create new ones)

Group Policy Editor (NT4)

Watch out for Tattoo effect

User and Group Profiles

Platform specific so use platform tool to change from a Local to a Roaming profile Can use new profiles tool to change SIDs (NTUser.DAT)

Logon Scripts (Know how they work)

User and Group mapping to Unix/Linux

username map facility may be needed

Use 'net groupmap' to connect NT4 groups to Unix groups

Use pdbedit to set/change user configuration

NOTE:

If migrating to LDAP back end it may be easier to dump initial LDAP database to LDIF, then edit, then reload into LDAP

OS specific scripts / programs may be needed

Add / delete Users

Note OS limits on size of name (Linux 8 chars)

NT4 up to 254 chars

Add / delete machines

Applied only to domain members (note up to 16 chars)

Add / delete Groups

Note OS limits on size and nature

Linux limit is 16 char,

no spaces and no upper case chars (groupadd)

Migration Tools

Domain Control (NT4 Style)

Profiles, Policies, Access Controls, Security

Migration Tools

Samba: net, rpcclient, smbpasswd, pdbedit, profiles

Windows: NT4 Domain User Manager, Server Manager (NEXUS)

Authentication

New SAM back end (smbpasswd, tdbsam, ldapsam, mysqlsam)

32. SWAT - The Samba Web Administration Tool

There are many and varied opinions regarding the usefulness or otherwise of SWAT. No matter how hard one tries to produce the perfect configuration tool it remains an object of personal taste. SWAT is a tool that will allow web based configuration of samba. It has a wizard that may help to get samba configured quickly, it has context sensitive help on each smb.conf parameter, it provides for monitoring of current state of connection information, and it allows network wide MS Windows network password management.

32.1. Features and Benefits

There are network administrators who believe that it is a good idea to write systems documentation inside configuration files, for them SWAT will always be a nasty tool. SWAT does not store the configuration file in any intermediate form, rather, it stores only the parameter settings, so when SWAT writes the smb.conf file to disk it will write only those parameters that are at other than the default settings. The result is that all comments will be lost from the smb.conf file. Additionally, the parameters will be written back in internal ordering.

NOTE



So before using SWAT please be warned - SWAT will completely replace your smb.conf with a fully optimised file that has been stripped of all comments you might have placed there and only non-default settings will be written to the file.

32.1.1. Enabling SWAT for use

SWAT should be installed to run via the network super daemon. Depending on which system your Unix/Linux system has you will have either an **inetd** or **xinetd** based system.

The nature and location of the network super-daemon varies with the operating system implementation. The control file (or files) can be located in the file `/etc/inetd.conf` or in the directory `/etc/[x]inet.d` or similar.

The control entry for the older style file might be:

```
# swat is the Samba Web Administration Tool
swat stream tcp nowait.400 root /usr/sbin/swat swat
```

A control file for the newer style xinetd could be:

```
# default: off
```

```
# description: SWAT is the Samba Web Admin Tool. Use swat \  
#             to configure your Samba server. To use SWAT, \  
#             connect to port 901 with your favorite web browser.  
service swat  
{  
    port      = 901  
    socket_type = stream  
    wait      = no  
    only_from = localhost  
    user      = root  
    server    = /usr/sbin/swat  
    log_on_failure += USERID  
    disable   = yes  
}
```

Both the above examples assume that the `swat` binary has been located in the `/usr/sbin` directory. In addition to the above SWAT will use a directory access point from which it will load it's help files as well as other control information. The default location for this on most Linux systems is in the directory `/usr/share/samba/swat`. The default location using samba defaults will be `/usr/local/samba/swat`.

Access to SWAT will prompt for a logon. If you log onto SWAT as any non-root user the only permission allowed is to view certain aspects of configuration as well as access to the password change facility. The buttons that will be exposed to the non-root user are: **HOME**, **STATUS**, **VIEW**, **PASSWORD**. The only page that allows change capability in this case is **PASSWORD**.

So long as you log onto SWAT as the user `root` you should obtain full change and commit ability. The buttons that will be exposed includes: **HOME**, **GLOBALS**, **SHARES**, **PRINTERS**, **WIZARD**, **STATUS**, **VIEW**, **PASSWORD**.

32.1.2. Securing SWAT through SSL

Lots of people have asked about how to setup SWAT with SSL to allow for secure remote administration of Samba. Here is a method that works, courtesy of Markus Krieger

Modifications to the swat setup are as following:

1. install OpenSSL
2. generate certificate and private key

```
root# /usr/bin/openssl req -new -x509 -days 365 -nodes -config \  
    /usr/share/doc/packages/stunnel/stunnel.cnf \  
    -out /etc/stunnel/stunnel.pem -keyout /etc/stunnel/stunnel.pem
```

3. remove swat-entry from `[x]inetd`
4. start stunnel

```
root# stunnel -p /etc/stunnel/stunnel.pem -d 901 \  
    -l /usr/local/samba/bin/swat swat
```

afterwards simply contact to swat by using the URL <https://myhost:901>, accept the certificate and the SSL connection is up.

32.1.3. The SWAT Home Page

The SWAT title page provides access to the latest Samba documentation. The manual page for each samba component is accessible from this page as are the Samba-HOWTO-Collection (this document) as well as the O'Reilly book "Using Samba".

Administrators who wish to validate their samba configuration may obtain useful information from the man pages for the diagnostic utilities. These are available from the SWAT home page also. One diagnostic tool that is NOT mentioned on this page, but that is particularly useful is **ethereal**, available from <http://www.ethereal.com>.

WARNING



SWAT can be configured to run in *demo* mode. This is NOT recommended as it runs SWAT without authentication and with full administrative ability. ie: Allows changes to smb.conf as well as general operation with root privileges. The option that creates this ability is the `-a` flag to `swat`. *Do not use this in any production environment.*

32.1.4. Global Settings

The Globals button will expose a page that allows configuration of the global parameters in smb.conf. There are three levels of exposure of the parameters:

- *Basic* - exposes common configuration options.
- *Advanced* - exposes configuration options needed in more complex environments.
- *Developer* - exposes configuration options that only the brave will want to tamper with.

To switch to other than *Basic* editing ability click on either the *Advanced* or the *Developer* dial, then click the **Commit Changes** button.

After making any changes to configuration parameters make sure that you click on the **Commit Changes** button before moving to another area otherwise your changes will be immediately lost.

NOTE



SWAT has context sensitive help. To find out what each parameter is for simply click the **Help** link to the left of the configuration parameter.

32.1.5. Share Settings

To affect a currently configured share, simply click on the pull down button between the **Choose Share** and the **Delete Share** buttons, select the share you wish to operate on, then to edit the settings click on the **Choose Share** button, to delete the share simply press the **Delete Share** button.

To create a new share, next to the button labelled **Create Share** enter into the text field the name of the share to be created, then click on the **Create Share** button.

32.1.6. Printers Settings

To affect a currently configured printer, simply click on the pull down button between the **Choose Printer** and the **Delete Printer** buttons, select the printer you wish to operate on, then to edit the settings click on the **Choose Printer** button, to delete the share simply press the **Delete Printer** button.

To create a new printer, next to the button labelled **Create Printer** enter into the text field the name of the share to be created, then click on the **Create Printer** button.

32.1.7. The SWAT Wizard

The purpose of the SWAT Wizard is to help the Microsoft knowledgeable network administrator to configure Samba with a minimum of effort.

The Wizard page provides a tool for rewriting the `smb.conf` file in fully optimised format. This will also happen if you press the commit button. The two differ in that the rewrite button ignores any changes that may have been made, while the Commit button causes all changes to be affected.

The **Edit** button permits the editing (setting) of the minimal set of options that may be necessary to create a working samba server.

Finally, there are a limited set of options that will determine what type of server samba will be configured for, whether it will be a WINS server, participate as a WINS client, or operate with no WINS support. By clicking on one button you can elect to expose (or not) user home directories.

32.1.8. The Status Page

The status page serves a limited purpose. Firstly, it allows control of the samba daemons. The key daemons that create the samba server environment are: `smbd`, `nmbd`, `winbindd`.

The daemons may be controlled individually or as a total group. Additionally, you may set an automatic screen refresh timing. As MS Windows clients interact with Samba new `smbd` processes will be continually spawned. The auto-refresh facility will allow you to track the changing conditions with minimal effort.

Lastly, the Status page may be used to terminate specific `smbd` client connections in order to free files that may be locked.

32.1.9. The View Page

This page allows the administrator to view the optimised `smb.conf` file and if you are particularly masochistic will permit you also to see all possible global configuration parameters and their settings.

32.1.10. The Password Change Page

The Password Change page is a popular tool. This tool allows the creation, deletion, deactivation and reactivation of MS Windows networking users on the local machine. Alternatively, you can use this tool to change a local password for a user account.

When logged in as a non-root account the user will have to provide the old password as well as the new password (twice). When logged in as `root` only the new password is required.

One popular use for this tool is to change user passwords across a range of remote MS Windows servers.

Part V.

Troubleshooting

33. The samba checklist

33.1. Introduction

This file contains a list of tests you can perform to validate your Samba server. It also tells you what the likely cause of the problem is if it fails any one of these steps. If it passes all these tests then it is probably working fine.

You should do ALL the tests, in the order shown. We have tried to carefully choose them so later tests only use capabilities verified in the earlier tests. However, do not stop at the first error as there have been some instances when continuing with the tests has helped to solve a problem.

If you send one of the samba mailing lists an email saying "it doesn't work" and you have not followed this test procedure then you should not be surprised if your email is ignored.

33.2. Assumptions

In all of the tests it is assumed you have a Samba server called BIGSERVER and a PC called ACLIENT both in workgroup TESTGROUP.

The procedure is similar for other types of clients.

It is also assumed you know the name of an available share in your `smb.conf`. I will assume this share is called tmp. You can add a tmp share like this by adding the following to `smb.conf`:

```
[tmp]
comment = temporary files
path = /tmp
read only = yes
```

NOTE



These tests assume version 3.0 or later of the samba suite. Some commands shown did not exist in earlier versions.

Please pay attention to the error messages you receive. If any error message reports that your server is being unfriendly you should first check that your IP name resolution is correctly set up. eg: Make sure your `/etc/resolv.conf` file points to name servers that really do exist.

Also, if you do not have DNS server access for name resolution please check that the settings for your `smb.conf` file results in `dns proxy = no`. The best way to check this is with `testparm smb.conf`.

It is helpful to monitor the log files during testing by using the **tail -F log_file_name** in a separate terminal console (use ctrl-alt-F1 through F6 or multiple terminals in X). Relevant log files can be found (for default installations) in `/usr/local/samba/var`. Also, connection logs from machines can be found here or possibly in `/var/log/samba` depending on how or if you specified logging in your `smb.conf` file.

If you make changes to your `smb.conf` file while going through these test, don't forget to restart `smbd` and `nmbd`.

33.3. The tests

DIAGNOSING YOUR SAMBA SERVER

1. In the directory in which you store your `smb.conf` file, run the command `testparm smb.conf`. If it reports any errors then your `smb.conf` configuration file is faulty.

NOTE



Your `smb.conf` file may be located in: `/etc/samba` Or in:
`/usr/local/samba/lib`

2. Run the command `ping BIGSERVER` from the PC and `ping ACLIENT` from the unix box. If you don't get a valid response then your TCP/IP software is not correctly installed. Note that you will need to start a "dos prompt" window on the PC to run `ping`. If you get a message saying host not found or similar then your DNS software or `/etc/hosts` file is not correctly setup. It is possible to run samba without DNS entries for the server and client, but I assume you do have correct entries for the remainder of these tests. Another reason why `ping` might fail is if your host is running firewall software. You will need to relax the rules to let in the workstation in question, perhaps by allowing access from another subnet (on Linux this is done via the `ipfwadm` program.)

NOTE



Modern Linux distributions install `ipchains/iptables` by default. This is a common problem that is often overlooked.

3. Run the command `smbclient -L BIGSERVER` on the unix box. You should get a list of available shares back. If you get a error message containing the string "Bad password" then you probably have either an incorrect **hosts allow**, **hosts deny** or **valid users** line in your `smb.conf`, or your guest account is not valid. Check what your guest account is using `testparm` and temporarily remove any **hosts allow**, **hosts deny**, **valid users** or **invalid users** lines. If you get a connection refused response then the `smbd` server may not be running. If you installed it in `inetd.conf` then you probably edited that file incorrectly. If you installed it as a daemon then check that it is running, and check that the `netbios-ssn` port is in a `LISTEN` state using `netstat -a`.

NOTE



Some Unix / Linux systems use **xinetd** in place of **inetd**. Check your system documentation for the location of the control file/s for your particular system implementation of this network super daemon.

If you get a session request failed then the server refused the connection. If it says "Your server software is being unfriendly" then its probably because you have invalid command line parameters to `smbd`, or a similar fatal problem with the initial startup of `smbd`. Also check your config file (`smb.conf`) for syntax errors with `testparm` and that the various directories where samba keeps its log and lock files exist. There are a number of reasons for which `smbd` may refuse or decline a session request. The most common of these involve one or more of the following `smb.conf` file entries:

```
hosts deny = ALL
hosts allow = xxx.xxx.xxx.xxx/yy
bind interfaces only = Yes
```

In the above, no allowance has been made for any session requests that will automatically translate to the loopback adaptor address 127.0.0.1. To solve this problem change these lines to:

```
hosts deny = ALL
hosts allow = xxx.xxx.xxx.xxx/yy 127.
```

Do *not* use the **bind interfaces only** parameter where you may wish to use the samba password change facility, or where `smbclient` may need to access a local service for name resolution or for local resource connections. (Note: the **bind interfaces only** parameter deficiency where it will not allow connections to the loopback address will be fixed soon). Another common cause of these two errors is having something already running on port 139, such as Samba (ie: `smbd` is running from `inetd` already) or something like Digital's Pathworks. Check your `inetd.conf` file before trying to start `smbd` as a daemon, it can avoid a lot of frustration! And yet another possible cause for failure of this test is when the subnet mask and / or broadcast address settings are incorrect. Please check that the network interface IP Address / Broadcast Address / Subnet Mask settings are correct and that Samba has correctly noted these in the `log.nmb` file.

4. Run the command `nmblookup -B BIGSERVER _SAMBA_`. You should get the IP address of your Samba server back. If you don't then `nmbd` is incorrectly installed. Check your `inetd.conf` if you run it from there, or that the daemon is running and listening to udp port 137. One common problem is that many `inetd` implementations can't take many parameters on the command line. If this is the case then create a one-line script that contains the right parameters and run that from `inetd`.
5. run the command `nmblookup -B ACLIENT '*'` You should get the PC's IP address back. If you don't then the client software on the PC isn't installed correctly, or isn't started, or you got the name of the PC wrong. If `ACLIENT` doesn't resolve via DNS then use the IP address of the client in the above test.

6. Run the command `nmblookup -d 2 '*'`. This time we are trying the same as the previous test but are trying it via a broadcast to the default broadcast address. A number of Netbios/TCPIP hosts on the network should respond, although Samba may not catch all of the responses in the short time it listens. You should see got a positive name query response messages from several hosts. If this doesn't give a similar result to the previous test then nmblookup isn't correctly getting your broadcast address through its automatic mechanism. In this case you should experiment with the **interfaces** option in `smb.conf` to manually configure your IP address, broadcast and netmask. If your PC and server aren't on the same subnet then you will need to use the `-B` option to set the broadcast address to that of the PCs subnet. This test will probably fail if your subnet mask and broadcast address are not correct. (Refer to TEST 3 notes above).
7. Run the command `smbclient //BIGSERVER/TMP`. You should then be prompted for a password. You should use the password of the account you are logged into the unix box with. If you want to test with another account then add the `-U accountname` option to the end of the command line. eg: `smbclient //bigserver/tmp -Ujohndoe`

NOTE

It is possible to specify the password along with the username as follows: `smbclient //bigserver/tmp -Ujohn-doe%secret`

Once you enter the password you should get the `smb>` prompt. If you don't then look at the error message. If it says invalid network name then the service `"tmp"` is not correctly setup in your `smb.conf`. If it says bad password then the likely causes are:

- a) you have shadow passwords (or some other password system) but didn't compile in support for them in `smbd`
- b) your **valid users** configuration is incorrect
- c) you have a mixed case password and you haven't enabled the **password level** option at a high enough level
- d) the **path** = line in `smb.conf` is incorrect. Check it with `testparm`
- e) you enabled password encryption but didn't map unix to samba users

Once connected you should be able to use the commands **dir get put** etc. Type **help command** for instructions. You should especially check that the amount of free disk space shown is correct when you type **dir**.

8. On the PC, type the command `net view \\BIGSERVER`. You will need to do this from within a "dos prompt" window. You should get back a list of available shares on the server. If you get a network name not found or similar error then netbios name resolution is not working. This is usually caused by a problem in `nmbd`. To overcome it you could do one of the following (you only need to choose one of them):
 - a) fixup the `nmbd` installation
 - b) add the IP address of `BIGSERVER` to the **wins server** box in the advanced tcp/ip setup on the PC.
 - c) enable windows name resolution via DNS in the advanced section of the tcp/ip setup
 - d) add `BIGSERVER` to your `lmhosts` file on the PC.

If you get a invalid network name or bad password error then the same fixes apply as they did for the `smbclient -L` test above. In particular, make sure your **hosts allow** line is correct (see the man pages) Also, do not overlook that fact that when the workstation requests the connection to the samba server it will attempt to connect using the name with which you logged onto your Windows machine. You need to make sure that an account exists on your Samba server with that exact same name and password. If you get specified computer is not receiving requests or similar it probably means that the host is not contactable via tcp services. Check to see if the host is running tcp wrappers, and if so add an entry in the `hosts.allow` file for your client (or subnet, etc.)

9. Run the command `net use x: \\BIGSERVER\TMP`. You should be prompted for a password then you should get a `command completed successfully` message. If not then your PC software is incorrectly installed or your `smb.conf` is incorrect. make sure your **hosts allow** and other config lines in `smb.conf` are correct. It's also possible that the server can't work out what user name to connect you as. To see if this is the problem add the line `user = username` to the `[tmp]` section of `smb.conf` where `username` is the username corresponding to the password you typed. If you find this fixes things you may need the username mapping option. It might also be the case that your client only sends encrypted passwords and you have `encrypt passwords = no` in `smb.conf` Turn it back on to fix.
10. Run the command `nmblookup -M testgroup` where `testgroup` is the name of the workgroup that your Samba server and Windows PCs belong to. You should get back the IP address of the master browser for that workgroup. If you don't then the election process has failed. Wait a minute to see if it is just being slow then try again. If it still fails after that then look at the browsing options you have set in `smb.conf`. Make sure you have `preferred master = yes` to ensure that an election is held at startup.
11. >From file manager try to browse the server. Your samba server should appear in the browse list of your local workgroup (or the one you specified in `smb.conf`). You should be able to double click on the name of the server and get a list of shares. If you get a "invalid password" error when you do then you are probably running WinNT and it is refusing to browse a server that has no encrypted password capability and is in user level security mode. In this case either set `security = server` AND `password server = Windows_NT_Machine` in your `smb.conf` file, or make sure `encrypted passwords` is set to "yes".

33.4. Still having troubles?

Read the chapter on [Analysing and Solving Problems](#).

34. Analysing and solving samba problems

There are many sources of information available in the form of mailing lists, RFC's and documentation. The docs that come with the samba distribution contain very good explanations of general SMB topics such as browsing.

34.1. Diagnostics tools

One of the best diagnostic tools for debugging problems is Samba itself. You can use the `-d` option for both `smbd` and `nmbd` to specify what debug level at which to run. See the man pages on `smbd`, `nmbd` and `smb.conf` for more information on debugging options. The debug level can range from 1 (the default) to 10 (100 for debugging passwords).

Another helpful method of debugging is to compile samba using the `gcc -g` flag. This will include debug information in the binaries and allow you to attach `gdb` to the running `smbd` / `nmbd` process. In order to attach `gdb` to an `smbd` process for an NT workstation, first get the workstation to make the connection. Pressing `ctrl-alt-delete` and going down to the domain box is sufficient (at least, on the first time you join the domain) to generate a `'LsaEnumTrustedDomains'`. Thereafter, the workstation maintains an open connection, and therefore there will be an `smbd` process running (assuming that you haven't set a really short `smbd` idle timeout) So, in between pressing `ctrl alt delete`, and actually typing in your password, you can attach `gdb` and continue.

Some useful samba commands worth investigating:

```
$ testparam | more
$ smbclient -L //{netbios name of server}
```

An SMB enabled version of `tcpdump` is available from <http://www.tcpdump.org/>. `Ethereal`, another good packet sniffer for Unix and Win32 hosts, can be downloaded from <http://www.ethereal.com>.

For tracing things on the Microsoft Windows NT, `Network Monitor` (aka. `netmon`) is available on the Microsoft Developer Network CD's, the Windows NT Server install CD and the SMS CD's. The version of `netmon` that ships with SMS allows for dumping packets between any two computers (i.e. placing the network interface in promiscuous mode). The version on the NT Server install CD will only allow monitoring of network traffic directed to the local NT box and broadcasts on the local subnet. Be aware that `Ethereal` can read and write `netmon` formatted files.

34.2. Installing 'Network Monitor' on an NT Workstation or a Windows 9x box

Installing `netmon` on an NT workstation requires a couple of steps. The following are for installing `Netmon V4.00.349`, which comes with Microsoft Windows NT Server

4.0, on Microsoft Windows NT Workstation 4.0. The process should be similar for other versions of Windows NT / Netmon. You will need both the Microsoft Windows NT Server 4.0 Install CD and the Workstation 4.0 Install CD.

Initially you will need to install Network Monitor Tools and Agent on the NT Server. To do this

- Goto **Start - Settings - Control Panel - Network - Services - Add**
- Select the **Network Monitor Tools and Agent** and click on **OK**.
- Click **OK** on the Network Control Panel.
- Insert the Windows NT Server 4.0 install CD when prompted.

At this point the Netmon files should exist in %SYSTEMROOT%\System32\netmon*. *. Two subdirectories exist as well, `parsers\` which contains the necessary DLL's for parsing the netmon packet dump, and `captures\`.

In order to install the Netmon tools on an NT Workstation, you will first need to install the 'Network Monitor Agent' from the Workstation install CD.

- Goto **Start - Settings - Control Panel - Network - Services - Add**
- Select the **Network Monitor Agent** and click on **OK**.
- Click **OK** on the Network Control Panel.
- Insert the Windows NT Workstation 4.0 install CD when prompted.

Now copy the files from the NT Server in %SYSTEMROOT%\System32\netmon*. * to %SYSTEMROOT%\System32\netmon*. * on the Workstation and set permissions as you deem appropriate for your site. You will need administrative rights on the NT box to run netmon.

To install Netmon on a Windows 9x box install the network monitor agent from the Windows 9x CD (`\admin\nettools\netmon`). There is a readme file located with the netmon driver files on the CD if you need information on how to do this. Copy the files from a working Netmon installation.

34.3. Useful URL's

- See how Scott Merrill simulates a BDC behavior at <http://www.skippy.net/linux/smb-howto.html>.
- FTP site for older SMB specs: <ftp://ftp.microsoft.com/developr/drg/CIFS/>

34.4. Getting help from the mailing lists

There are a number of Samba related mailing lists. Go to <http://samba.org>, click on your nearest mirror and then click on **Support** and then click on **Samba related mailing lists**.

For questions relating to Samba TNG go to <http://www.samba-tng.org/> It has been requested that you don't post questions about Samba-TNG to the main stream Samba lists.

If you post a message to one of the lists please observe the following guide lines :

- Always remember that the developers are volunteers, they are not paid and they never guarantee to produce a particular feature at a particular time. Any time lines are 'best guess' and nothing more.
- Always mention what version of samba you are using and what operating system its running under. You should probably list the relevant sections of your `smb.conf` file, at least the options in [global] that affect PDC support.
- In addition to the version, if you obtained Samba via CVS mention the date when you last checked it out.

- Try and make your question clear and brief, lots of long, convoluted questions get deleted before they are completely read ! Don't post html encoded messages (if you can select colour or font size its html).
- If you run one of those nifty 'I'm on holidays' things when you are away, make sure its configured to not answer mailing lists.
- Don't cross post. Work out which is the best list to post to and see what happens, i.e. don't post to both samba-ntdom and samba-technical. Many people active on the lists subscribe to more than one list and get annoyed to see the same message two or more times. Often someone will see a message and thinking it would be better dealt with on another, will forward it on for you.
- You might include *partial* log files written at a debug level set to as much as 20. Please don't send the entire log but enough to give the context of the error messages.
- (Possibly) If you have a complete netmon trace (from the opening of the pipe to the error) you can send the *.CAP file as well.
- Please think carefully before attaching a document to an email. Consider pasting the relevant parts into the body of the message. The samba mailing lists go to a huge number of people, do they all need a copy of your smb.conf in their attach directory?

34.5. How to get off the mailinglists

To have your name removed from a samba mailing list, go to the same place you went to to get on it. Go to <http://lists.samba.org>, click on your nearest mirror and then click on **Support** and then click on **Samba related mailing lists**. Or perhaps see [here](#)

Please don't post messages to the list asking to be removed, you will just be referred to the above address (unless that process failed in some way...)

35. Reporting Bugs

35.1. Introduction

Please report bugs using [bugzilla](#).

Please take the time to read this file before you submit a bug report. Also, please see if it has changed between releases, as we may be changing the bug reporting mechanism at some time.

Please also do as much as you can yourself to help track down the bug. Samba is maintained by a dedicated group of people who volunteer their time, skills and efforts. We receive far more mail about it than we can possibly answer, so you have a much higher chance of an answer and a fix if you send us a "developer friendly" bug report that lets us fix it fast.

Do not assume that if you post the bug to the `comp.protocols.smb` newsgroup or the mailing list that we will read it. If you suspect that your problem is not a bug but a configuration problem then it is better to send it to the Samba mailing list, as there are (at last count) 5000 other users on that list that may be able to help you.

You may also like to look through the recent mailing list archives, which are conveniently accessible on the Samba web pages at <http://samba.org/samba/>.

35.2. General info

Before submitting a bug report check your config for silly errors. Look in your log files for obvious messages that tell you that you've misconfigured something and run `testparm` to test your config file for correct syntax.

Have you run through the [diagnosis](#)? This is very important.

If you include part of a log file with your bug report then be sure to annotate it with exactly what you were doing on the client at the time, and exactly what the results were.

35.3. Debug levels

If the bug has anything to do with Samba behaving incorrectly as a server (like refusing to open a file) then the log files will probably be very useful. Depending on the problem a log level of between 3 and 10 showing the problem may be appropriate. A higher level gives more detail, but may use too much disk space.

To set the debug level use the log level in your `smb.conf`. You may also find it useful to set the log level higher for just one machine and keep separate logs for each machine. To do this use:

```
log level = 10
log file = /usr/local/samba/lib/log.%m
include = /usr/local/samba/lib/smb.conf.%m
```

then create a file `/usr/local/samba/lib/smb.conf.machine` where machine is the name of the client you wish to debug. In that file put any `smb.conf` commands

you want, for example log level may be useful. This also allows you to experiment with different security systems, protocol levels etc on just one machine.

The `smb.conf` entry log level is synonymous with the parameter `debuglevel` that has been used in older versions of Samba and is being retained for backwards compatibility of `smb.conf` files.

As the log level value is increased you will record a significantly increasing level of debugging information. For most debugging operations you may not need a setting higher than 3. Nearly all bugs can be tracked at a setting of 10, but be prepared for a VERY large volume of log data.

35.4. Internal errors

If you get a INTERNAL ERROR message in your log files it means that Samba got an unexpected signal while running. It is probably a segmentation fault and almost certainly means a bug in Samba (unless you have faulty hardware or system software).

If the message came from `smbd` then it will probably be accompanied by a message which details the last SMB message received by `smbd`. This info is often very useful in tracking down the problem so please include it in your bug report.

You should also detail how to reproduce the problem, if possible. Please make this reasonably detailed.

You may also find that a core file appeared in a `corefiles` subdirectory of the directory where you keep your samba log files. This file is the most useful tool for tracking down the bug. To use it you do this:

```
$ gdb smbd core
```

adding appropriate paths to `smbd` and `core` so `gdb` can find them. If you don't have `gdb` then try `dbx`. Then within the debugger use the command `where` to give a stack trace of where the problem occurred. Include this in your report.

If you know any assembly language then do a `disass` of the routine where the problem occurred (if its in a library routine then disassemble the routine that called it) and try to work out exactly where the problem is by looking at the surrounding code. Even if you don't know assembly then including this info in the bug report can be useful.

35.5. Attaching to a running process

Unfortunately some unices (in particular some recent linux kernels) refuse to dump a core file if the task has changed uid (which `smbd` does often). To debug with this sort of system you could try to attach to the running process using `gdb smbd PID` where you get PID from `smbstatus`. Then use `c` to continue and try to cause the core dump using the client. The debugger should catch the fault and tell you where it occurred.

35.6. Patches

The best sort of bug report is one that includes a fix! If you send us patches please use `diff -u` format if your version of `diff` supports it, otherwise use `diff -c4`. Make sure you do the diff against a clean version of the source and let me know exactly what version you used.

Part VI.

Appendixes

36. How to compile SAMBA

You can obtain the samba source from the [samba website](#). To obtain a development version, you can download samba from CVS or using rsync.

36.1. Access Samba source code via CVS

36.1.1. Introduction

Samba is developed in an open environment. Developers use CVS (Concurrent Versioning System) to "checkin" (also known as "commit") new source code. Samba's various CVS branches can be accessed via anonymous CVS using the instructions detailed in this chapter.

This chapter is a modified version of the instructions found at <http://samba.org/samba/cvs.html>

36.1.2. CVS Access to samba.org

The machine samba.org runs a publicly accessible CVS repository for access to the source code of several packages, including samba, rsync, distcc, ccache and jitterbug. There are two main ways of accessing the CVS server on this host.

36.1.2.1. Access via CVSweb

You can access the source code via your favourite WWW browser. This allows you to access the contents of individual files in the repository and also to look at the revision history and commit logs of individual files. You can also ask for a diff listing between any two versions on the repository.

Use the URL : <http://samba.org/cgi-bin/cvsweb>

36.1.2.2. Access via cvs

You can also access the source code via a normal cvs client. This gives you much more control over what you can do with the repository and allows you to checkout whole source trees and keep them up to date via normal cvs commands. This is the preferred method of access if you are a developer and not just a casual browser.

To download the latest cvs source code, point your browser at the URL : <http://www.cyclic.com/>. and click on the 'How to get cvs' link. CVS is free software under the GNU GPL (as is Samba). Note that there are several graphical CVS clients which provide a graphical interface to the sometimes mundane CVS commands. Links to theses clients are also available from the Cyclic website.

To gain access via anonymous cvs use the following steps. For this example it is assumed that you want a copy of the samba source code. For the other source code repositories on this system just substitute the correct package name

RETRIEVING SAMBA USING CVS

1. Install a recent copy of cvs. All you really need is a copy of the cvs client binary.
2. Run the command `cvs -d :pserver:cvs@samba.org:/cvsroot login`
3. When it asks you for a password type cvs.

4. Run the command `cvs -d :pserver:cvs@samba.org:/cvsroot co samba` This will create a directory called `samba` containing the latest samba source code (i.e. the HEAD tagged cvs branch). This currently corresponds to the 3.0 development tree. CVS branches other than HEAD can be obtained by using the `-r` and defining a tag name. A list of branch tag names can be found on the "Development" page of the samba web site. A common request is to obtain the latest 3.0 release code. This could be done by using the following user input: `cvs -d :pserver:cvs@samba.org:/cvsroot co -r SAMBA_3.0 samba`
5. Whenever you want to merge in the latest code changes use the following command from within the `samba` directory: `cvs update -d -P`

36.2. Accessing the samba sources via rsync and ftp

`pserver.samba.org` also exports unpacked copies of most parts of the CVS tree at <ftp://pserver.samba.org/pub/unpacked> and also via anonymous rsync at <rsync://pserver.samba.org/ftp/unpacked/>. I recommend using rsync rather than ftp. See [the rsync homepage](#) for more info on rsync.

The disadvantage of the unpacked trees is that they do not support automatic merging of local changes like CVS does. rsync access is most convenient for an initial install.

36.3. Verifying Samba's PGP signature

In these days of insecurity, it's strongly recommended that you verify the PGP signature for any source file before installing it. Even if you're not downloading from a mirror site, verifying PGP signatures should be a standard reflex.

With that said, go ahead and download the following files:

```
$ wget http://us1.samba.org/samba/ftp/samba-2.2.8a.tar.asc
$ wget http://us1.samba.org/samba/ftp/samba-pubkey.asc
```

The first file is the PGP signature for the Samba source file; the other is the Samba public PGP key itself. Import the public PGP key with:

```
$ gpg --import samba-pubkey.asc
```

And verify the Samba source code integrity with:

```
$ gzip -d samba-2.2.8a.tar.gz
$ gpg --verify samba-2.2.8a.tar.asc
```

If you receive a message like, "Good signature from Samba Distribution Verification Key..." then all is well. The warnings about trust relationships can be ignored. An example of what you would not want to see would be: `gpg: BAD signature from "Samba Distribution Verification Key"`

36.4. Building the Binaries

To do this, first run the program `./configure` in the source directory. This should automatically configure Samba for your operating system. If you have unusual needs then you may wish to run

```
root#./configure --help
```

first to see what special options you can enable. Then executing

```
root#make
```

will create the binaries. Once it's successfully compiled you can use

```
root#make install
```

to install the binaries and manual pages. You can separately install the binaries and/or man pages using

```
root#make installbin
```

and

```
root#make installman
```

Note that if you are upgrading for a previous version of Samba you might like to know that the old versions of the binaries will be renamed with a ".old" extension. You can go back to the previous version with

```
root#make revert
```

if you find this version a disaster!

36.4.1. Compiling samba with Active Directory support

In order to compile samba with ADS support, you need to have installed on your system:

- the MIT kerberos development libraries (either install from the sources or use a package). The heimdal libraries will not work.
- the OpenLDAP development libraries.

If your kerberos libraries are in a non-standard location then remember to add the configure option `--with-krb5=DIR`.

After you run configure make sure that `include/config.h` it generates contains lines like this:

```
#define HAVE_KRB5 1
#define HAVE_LDAP 1
```

If it doesn't then configure did not find your krb5 libraries or your ldap libraries. Look in `config.log` to figure out why and fix it.

36.4.1.1. Installing the required packages for Debian

On Debian you need to install the following packages:

```
libkrb5-dev
krb5-user
```

36.4.1.2. Installing the required packages for RedHat

On RedHat this means you should have at least:

```
krb5-workstation (for kinit)
krb5-libs (for linking with)
krb5-devel (because you are compiling from source)
```

in addition to the standard development environment.

Note that these are not standard on a RedHat install, and you may need to get them off CD2.

36.5. Starting the `smbd` and `nmbd`

You must choose to start `smbd` and `nmbd` either as daemons or from `inetd`. Don't try to do both! Either you can put them in `inetd.conf` and have them started on demand by `inetd`, or you can start them as daemons either from the command line or in `/etc/rc.local`. See the man pages for details on the command line options. Take particular care to read the bit about what user you need to be in order to start Samba. In many cases you must be root.

The main advantage of starting `smbd` and `nmbd` using the recommended daemon method is that they will respond slightly more quickly to an initial connection request.

36.5.1. Starting from `inetd.conf`

NOTE



The following will be different if you use NIS, NIS+ or LDAP to distribute services maps.

Look at your `/etc/services`. What is defined at port 139/tcp. If nothing is defined then add a line like this:

```
netbios-ssn    139/tcp
```

similarly for 137/udp you should have an entry like:

```
netbios-ns    137/udp
```

Next edit your `/etc/inetd.conf` and add two lines something like this:

```
netbios-ssn stream tcp nowait root /usr/local/samba/bin/smbd smbd
netbios-ns  dgram  udp  wait  root /usr/local/samba/bin/nmbd nmbd
```

The exact syntax of `/etc/inetd.conf` varies between unixes. Look at the other entries in `inetd.conf` for a guide.

NOTE



Some unixes already have entries like `netbios_ns` (note the underscore) in `/etc/services`. You must either edit `/etc/services` or `/etc/inetd.conf` to make them consistent.

NOTE



On many systems you may need to use the `interfaces` option in `smb.conf` to specify the IP address and netmask of your interfaces. Run `ifconfig` as root if you don't know what the broadcast is for your net. `nmbd` tries to determine it at run time, but fails on some unixes.

WARNING



Many unices only accept around 5 parameters on the command line in `inetd.conf`. This means you shouldn't use spaces between the options and arguments, or you should use a script, and start the script from **inetd**.

Restart `inetd`, perhaps just send it a HUP. If you have installed an earlier version of `nmbd` then you may need to kill `nmbd` as well.

36.5.2. Alternative: starting it as a daemon

To start the server as a daemon you should create a script something like this one, perhaps calling it **startsm**.

```
#!/bin/sh
/usr/local/samba/bin/smbd -D
/usr/local/samba/bin/nmbd -D
```

then make it executable with **chmod +x startsm**

You can then run **startsm** by hand or execute it from `/etc/rc.local`

To kill it send a kill signal to the processes `nmbd` and `smbd`.

NOTE



If you use the SVR4 style init system then you may like to look at the `examples/svr4-startup` script to make Samba fit into that system.

36.6. Common Errors

'I'm using gcc 3 and I've compiled Samba-3 from the CVS and the binaries are very large files (40 Mb and 20 Mb). I've the same result with `--enable-shared ?`'

The dwarf format used by GCC 3 for storing debugging symbols is very inefficient. Strip the binaries, don't compile with `-g` or compile with `-gstabs`.

37. Portability

Samba works on a wide range of platforms but the interface all the platforms provide is not always compatible. This chapter contains platform-specific information about compiling and using samba.

37.1. HPUX

HP's implementation of supplementary groups is, er, non-standard (for hysterical reasons). There are two group files, `/etc/group` and `/etc/logingroup`; the system maps UIDs to numbers using the former, but `initgroups()` reads the latter. Most system admins who know the ropes symlink `/etc/group` to `/etc/logingroup` (hard link doesn't work for reasons too stupid to go into here). `initgroups()` will complain if one of the groups you're in in `/etc/logingroup` has what it considers to be an invalid ID, which means outside the range `[0..UID_MAX]`, where `UID_MAX` is (I think) 60000 currently on HP-UX. This precludes -2 and 65534, the usual `nobody` GIDs.

If you encounter this problem, make sure that the programs that are failing to `initgroups()` be run as users not in any groups with GIDs outside the allowed range.

This is documented in the HP manual pages under `setgroups(2)` and `passwd(4)`.

On HPUX you must use `gcc` or the HP Ansi compiler. The free compiler that comes with HP-UX is not Ansi compliant and cannot compile Samba.

37.2. SCO Unix

If you run an old version of SCO Unix then you may need to get important TCP/IP patches for Samba to work correctly. Without the patch, you may encounter corrupt data transfers using samba.

The patch you need is UOD385 Connection Drivers SLS. It is available from SCO (ftp.sco.com, directory SLS, files `uod385a.Z` and `uod385a.ltr.Z`).

37.3. DNIX

DNIX has a problem with `seteuid()` and `setegid()`. These routines are needed for Samba to work correctly, but they were left out of the DNIX C library for some reason.

For this reason Samba by default defines the macro `NO_EID` in the DNIX section of `includes.h`. This works around the problem in a limited way, but it is far from ideal, some things still won't work right.

To fix the problem properly you need to assemble the following two functions and then either add them to your C library or link them into Samba.

put this in the file `setegid.s`:

```
        .globl  _setegid
_setegid:
        moveq   #47,d0
        movl    #100,a0
```

```
        moveq    #1,d1
        movl    4(sp),a1
        trap    #9
        bccs    1$
        jmp     cerror
1$:
        clr1    d0
        rts
```

put this in the file `seteuid.s`:

```
        .globl  _seteuid
_seteuid:
        moveq    #47,d0
        movl    #100,a0
        moveq    #0,d1
        movl    4(sp),a1
        trap    #9
        bccs    1$
        jmp     cerror
1$:
        clr1    d0
        rts
```

after creating the above files you then assemble them using

```
$ as seteuid.s
$ as setegid.s
```

that should produce the files `seteuid.o` and `setegid.o`

then you need to add these to the LIBSM line in the DNIX section of the Samba Makefile. Your LIBSM line will then look something like this:

```
LIBSM = setegid.o seteuid.o -ln
```

You should then remove the line:

```
#define NO_EID
```

from the DNIX section of `includes.h`

37.4. RedHat Linux Rembrandt-II

By default RedHat Rembrandt-II during installation adds an entry to `/etc/hosts` as follows:

```
127.0.0.1 loopback "hostname"."domainname"
```

This causes Samba to loop back onto the loopback interface. The result is that Samba fails to communicate correctly with the world and therefor may fail to correctly negotiate who is the master browse list holder and who is the master browser.

Corrective Action: Delete the entry after the word loopback in the line starting 127.0.0.1

37.5. AIX

37.5.1. Sequential Read Ahead

Disabling Sequential Read Ahead using `vmtune -r 0` improves samba performance significantly.

37.6. Solaris

37.6.1. Locking improvements

Some people have been experiencing problems with `F_SETLKW64/fcntl` when running samba on solaris. The built in file locking mechanism was not scalable. Performance would degrade to the point where processes would get into loops of trying to lock a file. It woul try a lock, then fail, then try again. The lock attempt was failing before the grant was occurring. So the visible manifestation of this would be a handful of processes stealing all of the CPU, and when they were trussed they would be stuck if `F_SETLKW64` loops.

Sun released patches for Solaris 2.6, 8, and 9. The patch for Solaris 7 has not been released yet.

The patch revision for 2.6 is 105181-34 for 8 is 108528-19 and for 9 is 112233-04

After the install of these patches it is recommended to reconfigure and rebuild samba.

Thanks to Joe Meslovich for reporting

37.6.2. Winbind on Solaris 9

Nsswitch on Solaris 9 refuses to use the winbind nss module. This behavior is fixed by Sun in patch 113476-05 which as of March 2003 is not in any roll-up packages.

38. Samba and other CIFS clients

This chapter contains client-specific information.

38.1. Macintosh clients?

Yes. [Thursby](#) now have a CIFS Client / Server called [DAVE](#)

They test it against Windows 95, Windows NT and samba for compatibility issues. At the time of writing, DAVE was at version 1.0.1. The 1.0.0 to 1.0.1 update is available as a free download from the Thursby web site (the speed of finder copies has been greatly enhanced, and there are bug-fixes included).

Alternatives - There are two free implementations of AppleTalk for several kinds of UNIX machines, and several more commercial ones. These products allow you to run file services and print services natively to Macintosh users, with no additional support required on the Macintosh. The two free implementations are [Netatalk](#), and [CAP](#). What Samba offers MS Windows users, these packages offer to Macs. For more info on these packages, Samba, and Linux (and other UNIX-based systems) see http://www.eats.com/linux_mac_win.html

38.2. OS2 Client

38.2.1. How can I configure OS/2 Warp Connect or OS/2 Warp 4 as a client for Samba?

A more complete answer to this question can be found on <http://carol.wins.uva.nl/~leeuw/samba/warp>.

Basically, you need three components:

- The File and Print Client ('IBM Peer')
- TCP/IP ('Internet support')
- The "NetBIOS over TCP/IP" driver ('TCPBEUI')

Installing the first two together with the base operating system on a blank system is explained in the Warp manual. If Warp has already been installed, but you now want to install the networking support, use the "Selective Install for Networking" object in the "System Setup" folder.

Adding the "NetBIOS over TCP/IP" driver is not described in the manual and just barely in the online documentation. Start MPTS.EXE, click on OK, click on "Configure LAPS" and click on "IBM OS/2 NETBIOS OVER TCP/IP" in 'Protocols'. This line is then moved to 'Current Configuration'. Select that line, click on "Change number" and increase it from 0 to 1. Save this configuration.

If the Samba server(s) is not on your local subnet, you can optionally add IP names and addresses of these servers to the "Names List", or specify a WINS server ('NetBIOS Nameserver' in IBM and RFC terminology). For Warp Connect you may need to download an update for 'IBM Peer' to bring it on the same level as Warp 4. See the webpage mentioned above.

38.2.2. How can I configure OS/2 Warp 3 (not Connect), OS/2 1.2, 1.3 or 2.x for Samba?

You can use the free Microsoft LAN Manager 2.2c Client for OS/2 from <ftp://ftp.microsoft.com/BusSys>. See <http://carol.wins.uva.nl/~leeuw/lanman.html> for more information on how to install and use this client. In a nutshell, edit the file `\OS2VER` in the root directory of the OS/2 boot partition and add the lines:

```
20=setup.exe
20=netwksta.sys
20=netvdd.sys
```

before you install the client. Also, don't use the included NE2000 driver because it is buggy. Try the NE2000 or NS2000 driver from <ftp://ftp.cdrom.com/pub/os2/network/ndis/> instead.

38.2.3. How do I get printer driver download working for OS/2 clients?

First, create a share called `[PRINTDRV]` that is world-readable. Copy your OS/2 driver files there. Note that the `.EA_` files must still be separate, so you will need to use the original install files, and not copy an installed driver from an OS/2 system.

Install the NT driver first for that printer. Then, add to your `smb.conf` a parameter, `os2 driver map = filename`. Then, in the file specified by `filename`, map the name of the NT driver name to the OS/2 driver name as follows:

```
nt driver name = os2 driver name.device name, e.g.:
```

```
HP LaserJet 5L = LASERJET.HP LaserJet 5L
```

You can have multiple drivers mapped in this file.

If you only specify the OS/2 driver name, and not the device name, the first attempt to download the driver will actually download the files, but the OS/2 client will tell you the driver is not available. On the second attempt, it will work. This is fixed simply by adding the device name to the mapping, after which it will work on the first attempt.

38.3. Windows for Workgroups

38.3.1. Use latest TCP/IP stack from Microsoft

Use the latest TCP/IP stack from microsoft if you use Windows for workgroups.

The early TCP/IP stacks had lots of bugs.

Microsoft has released an incremental upgrade to their TCP/IP 32-Bit VxD drivers. The latest release can be found on their ftp site at <ftp.microsoft.com>, located in `/peropsys/windows/public/tcpip/wfwt32.exe`. There is an `update.txt` file there that describes the problems that were fixed. New files include `WINSOCK.DLL`, `TELNET.EXE`, `WSOCK.386`, `VNBT.386`, `WSTCP.386`, `TRACERT.EXE`, `NETSTAT.EXE`, and `NBTSTAT.EXE`.

38.3.2. Delete .pwl files after password change

WfWg does a lousy job with passwords. I find that if I change my password on either the unix box or the PC the safest thing to do is to delete the `.pwl` files in the windows directory. The PC will complain about not finding the files, but will soon get over it, allowing you to enter the new password.

If you don't do this you may find that WfWg remembers and uses the old password, even if you told it a new one.

Often WfWg will totally ignore a password you give it in a dialog box.

38.3.3. Configure WfW password handling

There is a program call `admincfg.exe` on the last disk (disk 8) of the WFW 3.11 disk set. To install it type `EXPAND A:\ADMINCFG.EX_ C:\WINDOWS\ADMINCFG.EXE`. Then add an icon for it via the Program Manager **New** Menu. This program allows you to control how WFW handles passwords. ie disable Password Caching etc for use with security = user

38.3.4. Case handling of passwords

Windows for Workgroups uppercases the password before sending it to the server. Unix passwords can be case-sensitive though. Check the [smb.conf\(5\)](#) information on password level to specify what characters samba should try to uppercase when checking.

38.3.5. Use TCP/IP as default protocol

To support print queue reporting you may find that you have to use TCP/IP as the default protocol under WfWg. For some reason if you leave Netbeui as the default it may break the print queue reporting on some systems. It is presumably a WfWg bug.

38.3.6. Speed improvement

Note that some people have found that setting `DefaultRcvWindow` in the `[MSTCP]` section of the `SYSTEM.INI` file under WfWg to 3072 gives a big improvement. I don't know why.

My own experience with `DefaultRcvWindow` is that I get much better performance with a large value (16384 or larger). Other people have reported that anything over 3072 slows things down enormously. One person even reported a speed drop of a factor of 30 when he went from 3072 to 8192. I don't know why.

38.4. Windows '95/'98

When using Windows 95 OEM SR2 the following updates are recommended where Samba is being used. Please NOTE that the above change will affect you once these updates have been installed.

There are more updates than the ones mentioned here. You are referred to the Microsoft Web site for all currently available updates to your specific version of Windows 95.

Kernel Update: `KRNLUPD.EXE`

Ping Fix: `PINGUPD.EXE`

RPC Update: `RPCRTUPD.EXE`

TCP/IP Update: `VIPUPD.EXE`

Redirector Update: `VRDRUPD.EXE`

Also, if using MS Outlook it is desirable to install the **OLEUPD.EXE** fix. This fix may stop your machine from hanging for an extended period when exiting Outlook and you may also notice a significant speedup when accessing network neighborhood services.

38.4.1. Speed improvement

Configure the win95 TCPIP registry settings to give better performance. I use a program called **MTUSPEED.exe** which I got off the net. There are various other utilities of this type freely available.

38.5. Windows 2000 Service Pack 2

There are several annoyances with Windows 2000 SP2. One of which only appears when using a Samba server to host user profiles to Windows 2000 SP2 clients in a Windows domain. This assumes that Samba is a member of the domain, but the problem will likely occur if it is not.

In order to serve profiles successfully to Windows 2000 SP2 clients (when not operating as a PDC), Samba must have `nt acl support = no` added to the file share which houses the roaming profiles. If this is not done, then the Windows 2000 SP2 client will complain about not being able to access the profile (Access Denied) and create multiple copies of it on disk (DOMAIN.user.001, DOMAIN.user.002, etc...). See the [smb.conf\(5\)](#) man page for more details on this option. Also note that the `nt acl support` parameter was formally a global parameter in releases prior to Samba 2.2.2.

The following is a minimal profile share:

```
[profile]
  path = /export/profile
  create mask = 0600
  directory mask = 0700
  nt acl support = no
  read only = no
```

The reason for this bug is that the Win2k SP2 client copies the security descriptor for the profile which contains the Samba server's SID, and not the domain SID. The client compares the SID for SAMBA\user and realizes it is different that the one assigned to DOMAIN\user. Hence the reason for the access denied message.

By disabling the `nt acl support` parameter, Samba will send the Win2k client a response to the `QuerySecurityDescriptor trans2` call which causes the client to set a default ACL for the profile. This default ACL includes

```
DOMAIN\user "Full Control">
```

NOTE



This bug does not occur when using winbind to create accounts on the Samba host for Domain users.

38.6. Windows NT 3.1

If you have problems communicating across routers with Windows NT 3.1 workstations, read [this Microsoft Knowledge Base article](#).

39. Samba Performance Tuning

39.1. Comparisons

The Samba server uses TCP to talk to the client. Thus if you are trying to see if it performs well you should really compare it to programs that use the same protocol. The most readily available programs for file transfer that use TCP are ftp or another TCP based SMB server.

If you want to test against something like a NT or WfWg server then you will have to disable all but TCP on either the client or server. Otherwise you may well be using a totally different protocol (such as Netbeui) and comparisons may not be valid.

Generally you should find that Samba performs similarly to ftp at raw transfer speed. It should perform quite a bit faster than NFS, although this very much depends on your system.

Several people have done comparisons between Samba and Novell, NFS or WinNT. In some cases Samba performed the best, in others the worst. I suspect the biggest factor is not Samba vs some other system but the hardware and drivers used on the various systems. Given similar hardware Samba should certainly be competitive in speed with other systems.

39.2. Socket options

There are a number of socket options that can greatly affect the performance of a TCP based server like Samba.

The socket options that Samba uses are settable both on the command line with the `-O` option, or in the `smb.conf` file.

The socket options section of the `smb.conf` manual page describes how to set these and gives recommendations.

Getting the socket options right can make a big difference to your performance, but getting them wrong can degrade it by just as much. The correct settings are very dependent on your local network.

The socket option `TCP_NODELAY` is the one that seems to make the biggest single difference for most networks. Many people report that adding socket options = `TCP_NODELAY` doubles the read performance of a Samba drive. The best explanation I have seen for this is that the Microsoft TCP/IP stack is slow in sending tcp ACKs.

39.3. Read size

The option read size affects the overlap of disk reads/writes with network reads/writes. If the amount of data being transferred in several of the SMB commands (currently `SMBwrite`, `SMBwriteX` and `SMBreadbrow`) is larger than this value then the server begins writing the data before it has received the whole packet from the network, or in the case of `SMBreadbrow`, it begins writing to the network before all the data has been read from disk.

This overlapping works best when the speeds of disk and network access are similar, having very little effect when the speed of one is much greater than the other.

The default value is 16384, but very little experimentation has been done yet to determine the optimal value, and it is likely that the best value will vary greatly between systems anyway. A value over 65536 is pointless and will cause you to allocate memory unnecessarily.

39.4. Max xmit

At startup the client and server negotiate a maximum transmit size, which limits the size of nearly all SMB commands. You can set the maximum size that Samba will negotiate using the `max xmit =` option in `smb.conf`. Note that this is the maximum size of SMB requests that Samba will accept, but not the maximum size that the `*client*` will accept. The client maximum receive size is sent to Samba by the client and Samba honours this limit.

It defaults to 65536 bytes (the maximum), but it is possible that some clients may perform better with a smaller transmit unit. Trying values of less than 2048 is likely to cause severe problems.

In most cases the default is the best option.

39.5. Log level

If you set the log level (also known as debug level) higher than 2 then you may suffer a large drop in performance. This is because the server flushes the log file after each operation, which can be very expensive.

39.6. Read raw

The read raw operation is designed to be an optimised, low-latency file read operation. A server may choose to not support it, however. and Samba makes support for read raw optional, with it being enabled by default.

In some cases clients don't handle read raw very well and actually get lower performance using it than they get using the conventional read operations.

So you might like to try `read raw = no` and see what happens on your network. It might lower, raise or not affect your performance. Only testing can really tell.

39.7. Write raw

The write raw operation is designed to be an optimised, low-latency file write operation. A server may choose to not support it, however. and Samba makes support for write raw optional, with it being enabled by default.

Some machines may find write raw slower than normal write, in which case you may wish to change this option.

39.8. Slow Logins

Slow logins are almost always due to the password checking time. Using the lowest practical password level will improve things.

39.9. LDAP

LDAP can be vastly improved by using the [ldap trust ids](#) parameter.

39.10. Client tuning

Often a speed problem can be traced to the client. The client (for example Windows for Workgroups) can often be tuned for better TCP performance. Check the sections on the various clients in [Samba and Other Clients](#).

39.11. Samba performance problem due changing kernel

Hi everyone. I am running Gentoo on my server and samba 2.2.8a. Recently I changed kernel version from linux-2.4.19-gentoo-r10 to linux-2.4.20-wolk4.0s. And now I have performance issue with samba. Ok many of you will probably say that move to vanilla sources...well I ried it too and it didn't work. I have 100mb LAN and two computers (linux + Windows2000). Linux server shares directory with DivX files, client (windows2000) plays them via LAN. Before when I was running 2.4.19 kernel everything was fine, but now movies freezes and stops...I tried moving files between server and Windows and it's terribly slow.

Grab mii-tool and check the duplex settings on the NIC. My guess is that it is a link layer issue, not an application layer problem. Also run ifconfig and verify that the framing error, collisions, etc... look normal for ethernet.

39.12. Corrupt tdb Files

Well today it happend, our first major problem using samba. Our samba PDC server has been hosting 3 TB of data to our 500+ users [Windows NT/XP] for the last 3 years using samba, no problem. But today all shares went SLOW; very slow. Also the main smbd kept spawning new processes so we had 1600+ running smbd's (normally we avg. 250). It crashed the SUN E3500 cluster twice. After alot of searching I decided to **rm /var/locks/*.tbl**. Happy again.

Q1) Is there any method of keeping the *.tbl files in top condition or how to early detect corruption?

A1) Yes, run **tdbbackup** each time after stoping nmbd and before starting nmbd.

Q2) What I also would like to mention is that the service latency seems alot lower then before the locks cleanup, any ideas on keeping it top notch?

A2) Yes! Samba answer as for Q1!

40. DNS and DHCP Configuration Guide

40.1. Note

This chapter did not make it into this release. It is planned for the published release of this document.

41. Further Resources

41.1. Websites

- *CIFS: Common Insecurities Fail Scrutiny* by "Hobbit"
- *Doing the Samba on Windows* by Financial Review
- *Implementing CIFS* by Christopher R. Hertel
- *Just What Is SMB?* by Richard Sharpe
- *Opening Windows Everywhere* by Mike Warfield
- *SMB HOWTO* by David Wood
- *SMB/CIFS by The Root* by "ledin"
- *The Story of Samba* by Christopher R. Hertel
- *The Unofficial Samba HOWTO* by David Lechnyr
- *Understanding the Network Neighborhood* by Christopher R. Hertel
- *Using Samba as a PDC* by Andrew Bartlett
- *PDF version of the Troubleshooting Techniques chapter* from the second edition of Sam's Teach Yourself Samba in 24 Hours (publishing date of Dec. 12, 2001)
- *Slide presentations* by Samba Team members
- *Introduction to Samba 3.0* by Motonobu Takahashi (written in Japanese).
- *Understanding the Network Neighborhood*, by team member Chris Hertel. This article appeared in the May 2001 issue of Linux Magazine.
- *Samba 2.0.x Troubleshooting guide* from Paul Green
- *Ten Years of Samba*
- *Samba Authenticated Gateway HOWTO*
- *An Introduction to Samba*
- *What is CIFS?*
- *WFWG: Password Caching and How It Affects LAN Manager Security* at Microsoft Knowledge Base

41.2. Related updates from microsoft

- *Enhanced Encryption for Windows 95 Password Cache*
- *Windows '95 File Sharing Updates*
- *Windows for Workgroups Sharing Updates*

41.3. Books